

# PHILIPS

Data handbook



Electronic  
components  
and materials

## Components and materials

Part 11

March 1984

Voltage dependent resistors

Light dependent resistors

Negative temperature coefficient thermistors

Positive temperature coefficient thermistors

Humidity sensor



# COMPONENTS AND MATERIALS

PART 11 - MARCH 1984

## NON-LINEAR RESISTORS

VOLTAGE DEPENDENT RESISTORS (VDR)

LIGHT DEPENDENT RESISTORS (LDR)

NEGATIVE TEMPERATURE COEFFICIENT THERMISTORS (NTC)

POSITIVE TEMPERATURE COEFFICIENT THERMISTORS (PTC)

HUMIDITY SENSOR

INDEX OF CATALOGUE NUMBERS





## DATA HANDBOOK SYSTEM

Our Data Handbook System is a comprehensive source of information on electronic components, sub-assemblies and materials; it is made up of four series of handbooks each comprising several parts.

ELECTRON TUBES	BLUE
SEMICONDUCTORS	RED
INTEGRATED CIRCUITS	PURPLE
COMPONENTS AND MATERIALS	GREEN

The several parts contain all pertinent data available at the time of publication, and each is revised and reissued periodically.

Where ratings or specifications differ from those published in the preceding edition they are pointed out by arrows. Where application information is given it is advisory and does not form part of the product specification.

If you need confirmation that the published data about any of our products are the latest available, please contact our representative. He is at your service and will be glad to answer your inquiries.

---

This information is furnished for guidance, and with no guarantee as to its accuracy or completeness; its publication conveys no licence under any patent or other right, nor does the publisher assume liability for any consequence of its use; specifications and availability of goods mentioned in it are subject to change without notice; it is not to be reproduced in any way, in whole or in part without the written consent of the publisher.

---

May 1980

## ELECTRON TUBES (BLUE SERIES)

The blue series of data handbooks is comprised of the following parts:

- T1** Tubes for r.f. heating
- T2a** Transmitting tubes for communications, glass types
- T2b** Transmitting tubes for communications, ceramic types
- T3** Klystrons, travelling-wave tubes, microwave diodes
- ET3** Special Quality tubes, miscellaneous devices (will not be reprinted)
- T4** Magnetrons
- T5** Cathode-ray tubes  
Instrument tubes, monitor and display tubes, C.R. tubes for special applications
- T6** Geiger-Müller tubes
- T7** Gas-filled tubes  
Segment indicator tubes, indicator tubes, dry reed contact units, thyratrons, industrial rectifying tubes, ignitrons, high-voltage rectifying tubes, associated accessories
- T8** Picture tubes and components  
Colour TV picture tubes, black and white TV picture tubes, colour monitor tubes for data graphic display, monochrome monitor tubes for data graphic display, components for colour television, components for black and white television and monochrome data graphic display
- T9** Photo and electron multipliers  
Photomultiplier tubes, phototubes, single channel electron multipliers, channel electron multiplier plates
- T10** Camera tubes and accessories, image intensifiers
- T11** Microwave semiconductors and components

## SEMICONDUCTORS (RED SERIES)

The red series of data handbooks is comprised of the following parts:

- S1 Diodes**  
Small-signal germanium diodes, small-signal silicon diodes, voltage regulator diodes (< 1,5 W), voltage reference diodes, tuner diodes, rectifier diodes
- S2 Power diodes, thyristors, triacs**  
Rectifier diodes, voltage regulator diodes (> 1,5 W), rectifier stacks, thyristors, triacs
- S3 Small-signal transistors**
- S4a Low-frequency power transistors and hybrid modules**
- S4b High-voltage and switching power transistors**
- S5 Field-effect transistors**
- S6 R.F. power transistors and modules**
- S7 Microminiature semiconductors for hybrid circuits**
- S8 Devices for optoelectronics**  
Photosensitive diodes and transistors, light-emitting diodes, displays, photocouplers, infrared sensitive devices, photoconductive devices.
- S9 Power MOS transistors**
- S10 Wideband transistors and wideband hybrid IC modules**

## INTEGRATED CIRCUITS (PURPLE SERIES)

The purple series of data handbooks is comprised of the following parts:

- IC1** Bipolar ICs for radio and audio equipment
- IC2** Bipolar ICs for video equipment
- IC3** ICs for digital systems in radio, audio and video equipment
- IC4** Digital integrated circuits  
CMOS HE4000B family
- IC5** Digital integrated circuits – ECL  
ECL10 000 (GX family), ECL100 000 (HX family), dedicated designs
- IC6** Professional analogue integrated circuits
- IC7** Signetics bipolar memories
- IC8** Signetics analogue circuits
- IC9** Signetics TTL logic
- IC10** Signetics Integrated Fuse Logic (IFL)
- IC11** Microprocessors, microcomputers and peripheral circuitry



## COMPONENTS AND MATERIALS (GREEN SERIES)

The green series of data handbooks is comprised of the following parts:

- C1 Assemblies for industrial use**  
PLC modules, PC20 modules, HN1L FZ/30 series, NORbits 60-, 61-, 90-series, input devices, hybrid ICs
- C2 Television tuners, video modulators, surface acoustic wave filters**
- C3 Loudspeakers**
- C4 Ferroxcube potcores, square cores and cross cores**
- C5 Ferroxcube for power, audio/video and accelerators**
- C6 Synchronous motors and gearboxes**
- C7 Variable capacitors**
- C8 Variable mains transformers**
- C9 Piezoelectric quartz devices**  
Quartz crystal units, temperature compensated crystal oscillators, compact integrated oscillators, quartz crystal cuts for temperature measurements
- C10 Connectors**
- C11 Non-linear resistors**  
Voltage dependent resistors (VDR), light dependent resistors (LDR), negative temperature coefficient thermistors (NTC), positive temperature coefficient thermistors (PTC)
- C12 Variable resistors and test switches**
- C13 Fixed resistors**
- C14 Electrolytic and solid capacitors**
- C15 Film capacitors, ceramic capacitors**
- C16 Permanent magnet materials**
- C17 Stepping motors and electronics**
- C18 D.C. motors**
- C19 Piezoelectric ceramics**





## VOLTAGE DEPENDENT RESISTORS (VDR)



	page
<b>Survey</b>	<b>3</b>
<b>Introduction</b>	<b>4</b>
<b>Electrical properties</b>	<b>5</b>
<b>How to measure VDRS</b>	<b>13</b>
<b>Applications</b>	<b>15</b>
<b>Data sheets</b>	<b>19</b>

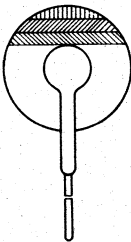

SURVEY

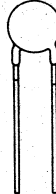
type	voltage V	current mA	dissipation W	$\beta$ -value	catalogue number
DISC, silicon carbide 	8 to 330	100 to 1	0,8	0,14 to 0,40	2322 552 0....
	8 to 330	100 to 1	1	0,14 to 0,40	2322 553 0....
	8 to 330	100 to 1	2	0,14 to 0,40	2322 554 0....
	8 to 330	100 to 1	3	0,14 to 0,40	2322 555 0....
ROD, silicon carbide 	56 to 1300	1 to 10	0,8	0,16 to 0,25	2322 564 02... 2322 564 90...
SMALL DISC silicon carbide titanium oxide 	6 to 18	1	0,1		2322 565 9000.
	2,7 to 68	1	0,25	0,20 to 0,28	2322 581 03...
zinc oxide 	100 to 750		0,1		2322 592 3....
			0,1		2322 592 6....
			0,25	0,02 to 0,035	2322 593 3....
			0,25		2322 593 6....
		0,4		2322 594 6....	
		0,6		2322 595 6....	



## INTRODUCTION

V(oltage) D(ependent) R(esistors), also called "Varistors", show a high degree of non-linearity between their resistance value and the applied voltage. They are made of non-homogeneous material giving a rectifying action at the contact of two particles.

Various materials are used to cause the voltage depending resistance. The principal ones are:

- silicon carbide;
- zinc oxide;
- titanium oxide.

The electrical characteristic of the conglomeration is determined by a large number of crystal contacts which form a complicated network of series and parallel rectifying contacts.

These resistors have found a diversity of applications in the different sectors of electronics. They offer a cheap and reliable solution for protection of electronic circuits, semiconductor components, collectors of motors, relay contacts, etc. against over-voltages and their consequences.

### MANUFACTURING PROCESS

Crystals of silicon carbide, or of metal oxides, with the right electrical and dimensional properties are pressed together with a ceramic binder to the shape of discs or rods. After a drying period the VDRs are sintered at a high temperature. Firing time, temperature and gaseous atmosphere have an important influence on the electrical characteristics. The contacts are metallized with silver or copper enabling good electrical contact. After leads have been soldered to the contacts the VDRs are lacquered and coded. Some types, made for clamp contacts or other mounting methods, are delivered unlacquered and without leads.

During and after the manufacturing process the electrical properties are controlled not only to ensure that the VDRs are within the specification but also to control stability and reliability of the resistors.

## ELECTRICAL PROPERTIES

## DIRECT CURRENT

The relation between voltage and current of a VDR can be approximated by:

$$V = C \cdot I^\beta \quad (1)$$

where  $V$  is the voltage in volts,  $I$  the current in amperes and  $C$  and  $\beta$  are constants. This equation is illustrated in Fig. 1. In principle the same characteristic is plotted for a specific type on a double logarithmic scale in Fig. 2. For not too small values of current this relation is a straight line which follows directly from the equation  $\log V = \log C + \beta \log I$ . In this case  $\beta$  is the directional coefficient of the straight line.

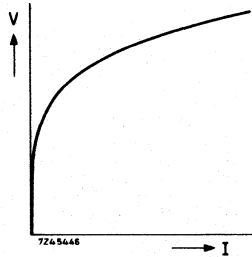

Fig. 1 Shape of the voltage/current characteristic of a VDR when plotted on a linear scale.

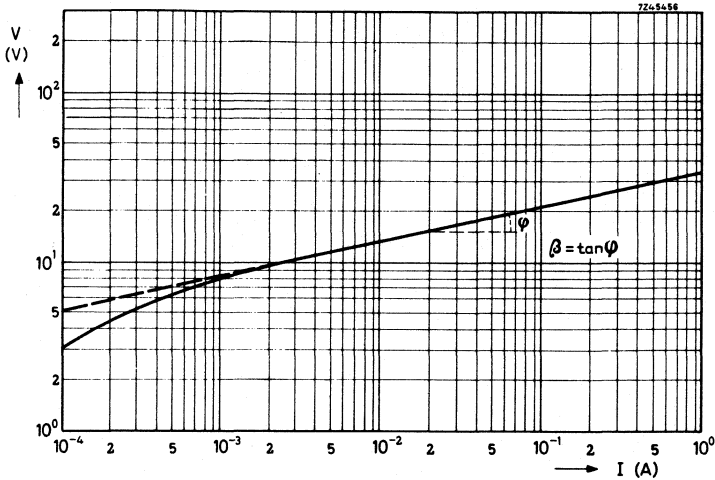

Fig. 2 Voltage/current characteristic of a VDR plotted on a logarithmic scale.

In order to determine the exact values of the constants  $C$  and  $\beta$  it is necessary to measure three points of the characteristic. Only when these are on a straight line when plotted on a double logarithmic scale, is extrapolation permitted (only to higher values). Equation (1) may also be written:

$$I = \left(\frac{V}{C}\right)^\alpha \quad (2)$$

in which:

$$\alpha = 1/\beta \quad (3a)$$

and

$$K = \frac{1}{C^{1/\beta}} = \frac{1}{C^\alpha} \quad (3b)$$

The VDRs do not have a polar effect; this means that when the voltage is changed from positive to negative, the current changes its direction, but retains its value. Strictly speaking, Eqs (1) and (2) are valid only when the absolute values are taken for  $I$  and  $V$ . In a.c. calculations this may be very important. For practical design, reference is made to the voltage/current characteristics given in the data sheets of the relevant VDR types.

#### Practical values and specification

The  $C$  and  $\beta$ -values of a VDR depend on the composition of the material and on the method used in the processing; furthermore, the  $C$ -value depends on the shape and the dimensions of the VDR.

→ Practical  $\beta$ -values are for SiC:  $\beta = 0,15$  to  $0,40$ , for ZnO:  $\beta = 0,02$  to  $0,035$  and for TiO<sub>2</sub>:  $\beta = 0,2$  to  $0,28$ . It is inherent to the material properties that the  $\beta$ -value of a VDR with a low  $C$ -value will always be higher than that of a VDR with a high  $C$ -value. Practical  $C$ -values range from 14 to a few thousand. As the method of fabrication compels a minimum thickness and, as will be seen further, enlarging of the surface area gives little change in the  $C$ -value, the latter has for practical reasons a limited lowest value.



According to Eq. (1) it is possible to specify the electrical characteristics of a VDR resistor by giving its C and  $\beta$ -values. The advantage of this specification is that only two parameters are used. The disadvantage is, however, that due to the inevitable tolerances on the  $\beta$ -values, the spread in voltages at low currents (in the working area) becomes very large. It is for this reason that the method of specifying by the C-value defined at 1 A is abandoned and we now specify the voltage across the VDR at currents which lie in the working area (1, 10 or 100 mA instead of 1 A). In this way it is possible to supply VDRs which have much closer tolerances in the area where they are used, see Fig. 10.

#### VDRs in series

For each VDR we can write the equation:

$$V = CI^\beta \quad (1)$$

When n equal elements are connected in series and a voltage of n times the original voltage is applied, the current will be the same as for V volts over one VDR. Consequently we may write for a series circuit of n VDRs:

$$nV = C' \cdot I^\beta \quad (4)$$

From Eqs (1) and (4) it is evident that,

$$C' = nC, \quad (5)$$

which means that the C-value of a VDR can be increased ad libitum by series connection.

#### VDRs in parallel

For one VDR again we have:

$$V = CI^\beta \quad (1)$$

Now when n of these VDRs are connected in parallel and the same voltage V is applied, the current in each VDR will still be the same. The total current in the circuit will be nI. This gives the following equation:

$$V = C''(nI)^\beta \quad (6)$$

From Eqs (1) and (6) it follows:

$$C'' = \frac{C}{n^\beta} \quad (7)$$

As VDRs have a  $\beta$ -value from 0,02 to 0,40, it is clear that the C-value will decrease very little by connecting two or more elements in parallel. When, e.g.  $\beta = 0,20$ , 32 VDRs are needed for a 50% reduction of the C-value. It is important that in parallel circuits all VDRs have about the same  $\beta$  and C-values, otherwise the current division will very much depend on the voltage across the circuit.

**Note:** On no occasion may a VDR be connected in parallel with the aim of obtaining higher power dissipation.

### Resistance value

When defining R as usual as the quotient of voltage and current, we find:

$$R = \frac{V}{I} = \frac{CI^\beta}{I} = \frac{C}{I^{1-\beta}} \quad (8)$$

or when starting from the form  $I = \left(\frac{V}{C}\right)^\alpha$ :

$$R = \frac{V}{I} = \frac{V}{\frac{V}{C^\alpha}} = \frac{C^\alpha}{V^{\alpha-1}} \quad (9)$$

From these equations it is once more evident that the resistance value is not a constant one, but is very much dependent on the values of voltage and current.

### Dissipated power

The power dissipated in a VDR is equal to the product of voltage and current, so it may be written:

$$W = I \cdot V = \left(\frac{V}{C}\right)^\alpha \cdot V = \frac{V^{\alpha+1}}{C^\alpha} \quad (10)$$

When the coefficient  $\alpha = 5$ , the power dissipated by the VDR is proportional to the 6th power of the voltage. A voltage increase of only 12% will, in this case, double the dissipated power. Consequently it is very important that the applied voltage does not rise above a certain maximum value, as otherwise the permissible rating will be exceeded.

This is even more cogent, as the VDRs have a negative temperature coefficient, which means that at higher dissipation (and accordingly higher temperature) the resistance value will decrease and the dissipated power will increase still more.

### Temperature coefficient

In the foregoing formulae no temperature effects have been taken into account. These, however, may not always be neglected, as the C-value has an appreciable negative temperature coefficient. The  $\beta$ -value is practically independent of the temperature. With good approximation it may be written:

$$C_t = C_0 (1 + at), \quad (11)$$

in which:

$C_t$  = C-value of the VDR at  $t$  °C;

$C_0$  = C-value of the VDR at 0 °C;

$a$  = temperature coefficient.

For different materials the value of  $a$  lies between  $-0,0010$  and  $-0,0018$ . Thus, for circuits where the current is constant, the temperature coefficient on voltage lies between  $-0,10$  and  $-0,18\%$  per degree K.

For circuits where the voltage is constant the temperature coefficient on current lies between  $+0,4$  and  $+0,8\%$  per degree K, depending on the  $\beta$ -value.

**High frequency alternating current**

For low frequencies the small capacitance of the VDR does not affect the voltage dependency of the resistance. For high frequencies, however, this parallel capacitance may not be neglected. For low voltages and currents they may even determine the impedance of the VDR. At high voltages, the influence of the capacitance is less serious; because in that case the resistance over which this capacitance is shunted has decreased. In general the effect of the capacitance in h.f. circuits will be an apparent increase of  $\beta$ . Furthermore the voltage/current graph on a logarithmic scale will no longer be a straight line.

A number of curves demonstrating this effect are given in Fig. 8.

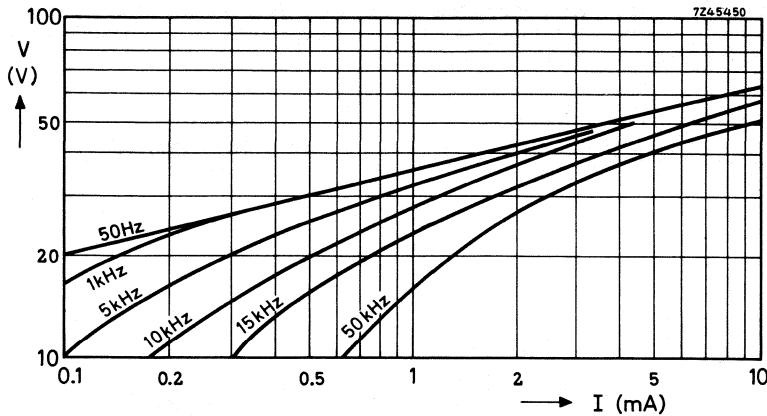

Fig. 8 Voltage/current relation for different frequencies.

**PERMISSIBLE DISSIPATION**

The temperature which a VDR will reach is determined by the dissipated power, the heat conductivity of the material, the contact with, and the nature of, the surrounding medium and by the ambient temperature. As already explained the dissipated power will increase rapidly with increasing voltage.

The cooling per degree Celsius, though increasing slightly with temperature, depends mainly on the total surface area of the VDR.

For most VDR types the maximum permissible body temperature is 125 °C.

ZINC-OXIDE VOLTAGE DEPENDENT RESISTORS

Unlike SiC types, the ZnO VDRs are mainly intended for applications requiring intermittent power dissipation, i.e. transient suppression and contact arc prevention. In their transient suppression role, the symmetrical mode of operation allows them to be connected directly across a.c. power lines carrying r.m.s. voltages of 60 to 460 V (currently available types). They are capable of withstanding voltage or current pulses with a high peak energy level. A typical  $\beta$  for this type of VDR is 0,03. This means that, if the current through the VDR increases by a factor of 10 within the straight-line portion of the characteristic, the voltage across it increases by a factor of 1,07

A typical V/I characteristic for one of these VDRs is shown in Fig. 9. The upward turn of the characteristic (decreasing non-linearity) is due to the increasing influence of the linear series resistance of the component as its non-linear resistance falls to very low values at extreme currents. A good approximation of the relationship between the voltage and the current in the curved portion of the characteristics is given by the expression:

$$V = CI^\beta + IR_s$$

where  $R_s$  is the series resistance of the VDR.

See further the data sheets of the VDR series 2322 592 6..., 2322 593 6..., 2322 594 6.... and 2322 595 6....

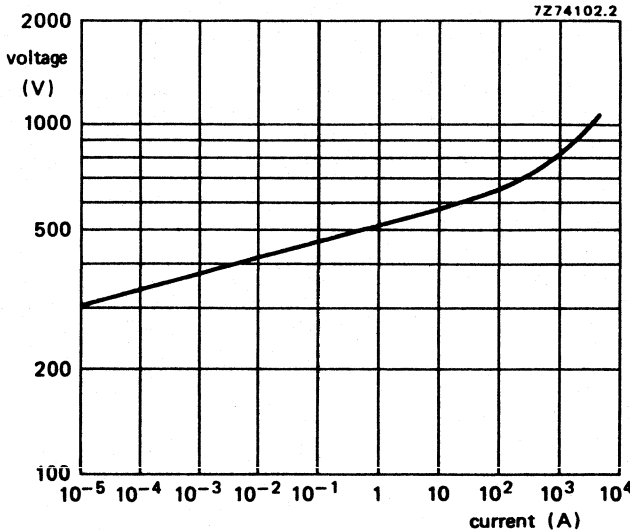

Fig. 9 Typical V/I characteristic of ZnO VDR 2322 595 62512 for 220 V mains supply.

**Normal operating conditions of the ZnO VDR**

Owing to the extreme nonlinearity of the voltage/current characteristic of ZnO VDRs, and the necessity to allow a margin for the extra dissipation during a transient, ensure that the maximum voltage applied across the VDR during normal operation never attains such a value that the specified average dissipation limit of the VDR is approached. This will never be a problem if the VDR is selected according to the figures for max. r.m.s. voltage in the data sheet. The peak value of the sinusoidal voltage applied to the VDR must always be less than the minimum voltage specified at 1 mA. If the applied voltage is other than sinusoidal, the VDR should be selected on the basis of the specified maximum peak working voltage.





## HOW TO MEASURE VOLTAGE DEPENDENT RESISTORS

The following points have to be considered when measuring VDRs.

1. Use only d.c. voltage.
2. Keep the measuring time as short as possible. Self-heating effects may influence the measurements due to the negative temperature coefficient of the VDRs.
3. When the VDRs are specified at a voltage and current which is above the maximum dissipation, pulses should be used. For instance all 2322 564 VDR types which are used in television circuits are measured under pulse-conditions. These types are measured with a rectangular current pulse having a duration of 10 ms.
4. The  $\beta$ -value measurement needs some explanation. As mentioned on page 5 the  $\beta$ -value is not always constant but depends on the voltage and current. The  $\beta$ -values of our discs are measured between 0,3 I and 3 I, those of our rods between I and 10 I (unless otherwise specified), where I is the current at which the VDR is specified. For example:

$$\beta = \log \frac{V_2}{V_1}; \text{ with } V_2 = \text{voltage at } 3 I, \\ V_1 = \text{voltage at } 0,3 I.$$

### TOLERANCES

Standard VDRs are specified with a certain tolerance on voltage and a spread on  $\beta$ -value. It can be seen in Fig. 10 that due to the spread in  $\beta$ -value the tolerance on voltage may increase at currents other than the specified current at which the VDR is measured.

For some applications, where tolerances have to be kept as low as possible, the VDRs are measured at a current or voltage which lies near to its working point in the circuit, e.g. the standard rod types for television, series 2322 564 02 are measured at 10 mA.

For other applications, especially spark suppression, it is often important to specify the VDR at two points: a point at low current or low voltage and a point at high current or high voltage.

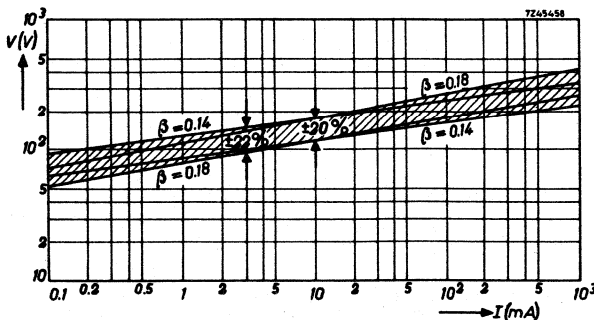

Fig. 10 Spread of voltage/current characteristic due to  $\beta$ -tolerance.





## APPLICATIONS

Some of the most important application principles are given in the following pages. Well known television applications are the VDR used as a rectifier of non-symmetrical pulses, and for stabilization against supply voltage variations and aging of components. The VDR is also used in TV sets across the primary of the frame output transformer for damping oscillations, while in other circuits VDRs fulfil the functions of voltage stabilization devices. Outside the entertainment field we find VDRs used in telecommunications as relay contact protectors. A special range of VDRs has been developed for this purpose. Similar application can be found in small battery motors where the VDR increases the commutator life considerably. There are many more uses for VDRs and the following selection is by no means complete.

### Contact-protection and spark suppression

Two principal circuits are used. As soon as the contacts open, the energy stored in the inductance ( $\frac{1}{2}LI^2$ ) is dissipated by the VDR, limiting the voltage across the contacts to a safe value.

Zinc oxide VDRs (2322 592/593/594/595 series) are designed especially for the suppression of voltage transients.

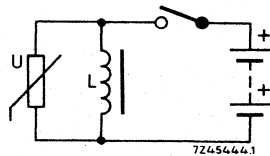
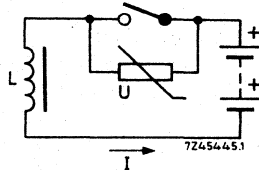

### Protection of small battery motors

Sparking brush contacts limit the commutator life and give rise to interference with nearby radio or audio circuits. A small VDR in parallel to the rotor windings prevents the sparking and so increases the commutator life considerably.

Multi-segment discs (3 to 6 VDR sections per disc) are available for incorporation into the commutator construction.

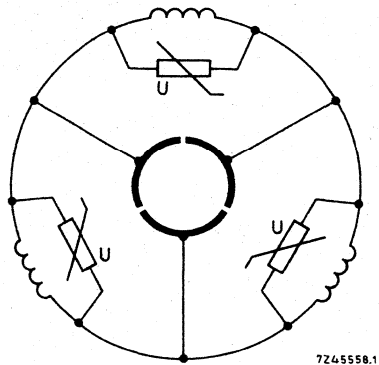

# VOLTAGE DEPENDENT RESISTORS

## VDR for adapting meter sensitivity

A VDR in series with a voltmeter or in parallel with a milliammeter enables part of the scale to be expanded for more accurate reading of measurements.

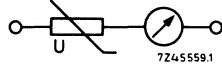

## Stabilization of a voltage without load when the supply voltage varies

It can be shown that the VDR stabilizes varying supply voltages by a factor

$$S = \frac{\Delta V/V}{\Delta V_2/V_2} = \frac{1}{\beta} - \frac{1-\beta}{\beta} \cdot x, \text{ where } x = V_2/V.$$

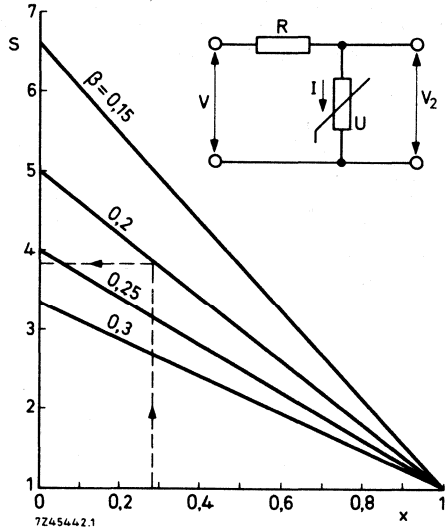

## Applications

### Stabilization of a voltage with load

$$S = \frac{1}{\beta} - \frac{1-\beta}{\beta} \cdot \frac{x+y}{1+y} \quad \text{where } x = V_2/V \text{ and } y = I_2/I_1.$$

The nomogram makes S easy to find.

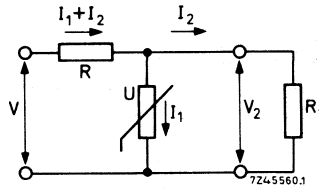
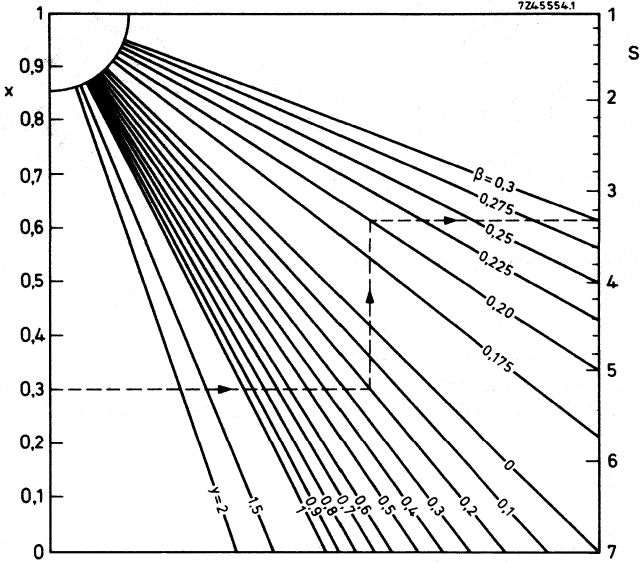

The silicon carbide and titanium oxide VDRs (2322 552 to 2322 555 series and 2322 581 series) are particularly suited for stabilization of d.c. voltages.

## Protection of a thyristor bridge in a washing machine

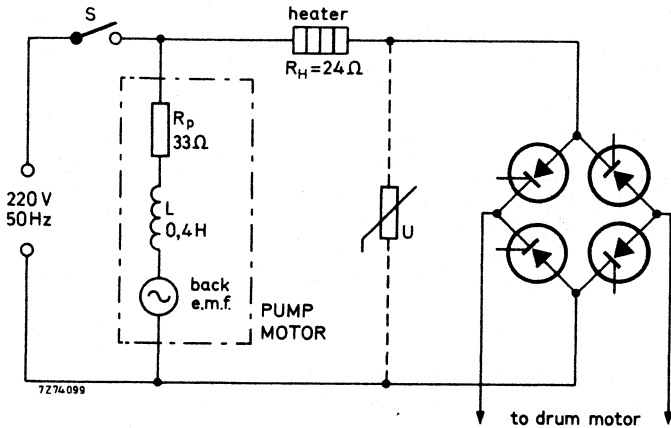

### Behaviour of the circuit without VDR protection

The measured peak current through the pump motor when S is closed is 1 A. The energy expended in establishing the electromagnetic field in the inductance of the motor is therefore:

$$\frac{I^2 L}{2} = \frac{0,4}{2} = 200 \text{ mJ.}$$

Without VDR protection, an initial current of 1 A will flow through the thyristor bridge when S opens, and a voltage sufficient to damage or destroy the thyristors will be developed. Arcing will occur across the opening contacts of the switch.

### → Behaviour of the circuit with VDR 2322 593 62512

On opening switch S, the peak voltage developed across the VDR is:

$$V = C_{\max} I^2 = 600 \text{ V.}$$

The thyristors in the bridge can withstand this voltage without damage.

The total energy returned to the circuit is 200 mJ. Of this 15,7 mJ are dissipated in the heater and 184,3 mJ are dissipated in the VDR. The VDR can withstand more than  $10^5$  transients containing this amount of energy.

## VOLTAGE DEPENDENT RESISTORS

silicon carbide disc

### QUICK REFERENCE DATA

D.C. voltage	
$I_{nom} = 100 \text{ mA}$	8 to 12 V
$I_{nom} = 10 \text{ mA}$	8 to 68 V
$I_{nom} = 1 \text{ mA}$	56 to 330 V
$\beta$ between $0,3 I_{nom}$ and $3 I_{nom}$	0,14 to 0,40
Maximum dissipation	0,8 W
Operating temperature range	
zero power	-25 to +125 °C
max. power	0 to + 55 °C

### APPLICATION

Voltage stabilization, contact protection and spark suppression.

### DESCRIPTION

A disc of silicon carbide with axial tinned copper leads. The disc is coated with tan coloured lacquer. It is not insulated.

### MECHANICAL DATA

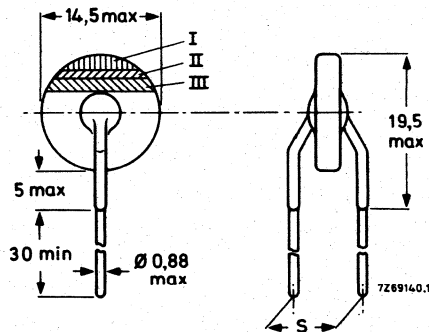

Fig. 1  $S = 9 \text{ mm}$  for types with C values up to 500.  $S = 10 \text{ mm}$  for others, see table.

**Marking**

A three-band colour code as shown in Fig. 1. This code indicates the three figures following the zero in the last part of the catalogue number shown in Table 1. The colours are in accordance with the standard VDR resistor colour code, e.g. type 2322 552 01161 is coded brown, brown, blue (100 mA, 8 V). See Table 2.

**Mass**

See Table 1.

**Mounting**

In any position by soldering.

**Robustness of terminations**

Tensile strength	20 N
Bending	10 N

**Soldering**

Resistance to heat max. 240 °C, max. 4 s

**ELECTRICAL DATA**

Tolerance on voltage at $I_{nom}$	$\pm 20\%$ or $\pm 10\%*$
Maximum dissipation	0,8 W
Asymmetry	max. 2%
Operating temperature range	
zero power	-25 to +125 °C
max. power	0 to + 55 °C

See further Table 1.

**PACKAGING**

100 resistors in a cardboard box.

\* The 10% types have an extra silver tipping.

Table 1 Catalogue numbers 2322 552 0....

suffix of catalogue number 20% on V*	d.c. current $I_{nom}$ mA	voltage at $I_{nom}$ V	$\beta$	C approx.	mass g	S max (Fig. 1) mm
1161	100	8	0,25 to 0,40	14	1,3	9
1181	100	10	0,25 to 0,40	18	1,3	9
1201	100	12	0,25 to 0,40	21	1,3	9
2161	10	8	0,25 to 0,40	25	1,3	9
2181	10	10	0,25 to 0,40	32	1,4	9
2201	10	12	0,25 to 0,40	40	1,4	9
2221	10	15	0,25 to 0,40	48	1,4	9
2241	10	18	0,21 to 0,35	57	1,45	9
2261	10	22	0,21 to 0,35	60	1,45	9
2281	10	27	0,21 to 0,35	70	1,45	9
2301	10	33	0,18 to 0,25	85	1,45	9
2321	10	39	0,18 to 0,25	100	1,45	9
2341	10	47	0,18 to 0,25	130	1,45	9
2361	10	56	0,18 to 0,25	150	1,45	9
2381	10	68	0,18 to 0,25	180	1,45	9
3361	1	56	0,14 to 0,23	190	1,45	9
3381	1	68	0,14 to 0,23	230	1,45	9
3401	1	82	0,14 to 0,21	300	1,5	9
3421	1	100	0,14 to 0,21	350	1,6	9
3441	1	120	0,14 to 0,21	400	1,65	9
3461	1	150	0,14 to 0,21	500	1,75	9
3481	1	180	0,14 to 0,21	600	1,9	10
3501	1	220	0,14 to 0,21	750	2,15	10
3521	1	270	0,14 to 0,21	900	2,3	10
3541	1	330	0,14 to 0,21	1100	2,6	10

\* For a 10% tolerance on voltage, replace last digit (1) of the catalogue number by a 2.

Table 2.

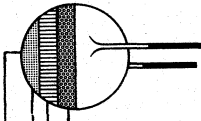

brown = 100 mA	brown/blue = 8 V	orange/blue = 56 V
red = 10 mA	brown/grey = 10 V	orange/grey = 68 V
orange = 1 mA	red/black = 12 V	yellow/black = 82 V
	red/red = 15 V	yellow/red = 100 V
	red/yellow = 18 V	yellow/yellow = 120 V
	red/blue = 22 V	yellow/blue = 150 V
	red/grey = 27 V	yellow/grey = 180 V
	orange/black = 33 V	green/black = 220 V
	orange/red = 39 V	green/red = 270 V
	orange/yellow = 47 V	green/yellow = 330 V

silver tipped  
10% tol.

untipped  
20% tol.

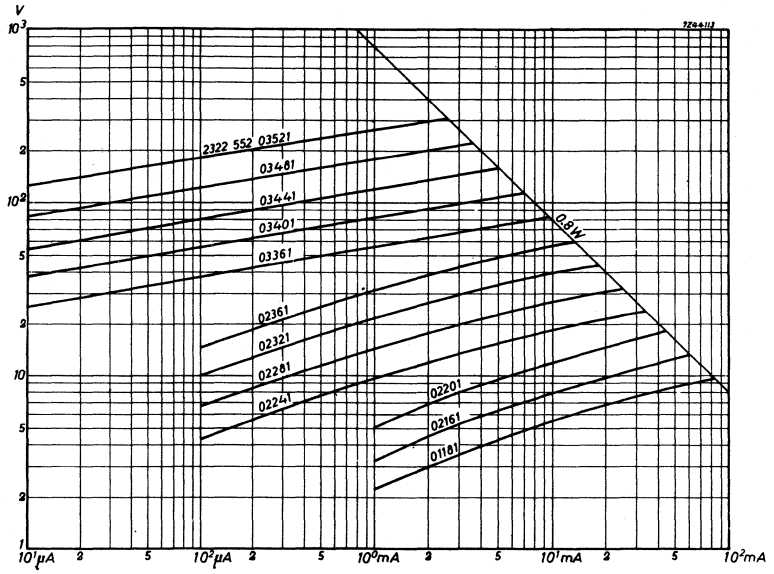

Fig. 2 Voltage/current characteristics.



## VOLTAGE DEPENDENT RESISTORS

silicon carbide disc

### QUICK REFERENCE DATA

D.C. voltage	
$I_{nom} = 100 \text{ mA}$	8 to 15 V
$I_{nom} = 10 \text{ mA}$	10 to 82 V
$I_{nom} = 1 \text{ mA}$	68 to 330 V
$\beta$ between $0,3 I_{nom}$ and $3 I_{nom}$	0,14 to 0,40
Maximum dissipation	1 W
Operating temperature range	
zero power	-25 to +125 °C
max. power	0 to + 55 °C

### APPLICATION

Voltage stabilization, contact protection and spark suppression.

### DESCRIPTION

A disc of silicon carbide with axial tinned copper leads. The disc is coated with tan coloured lacquer. It is not insulated.

### MECHANICAL DATA

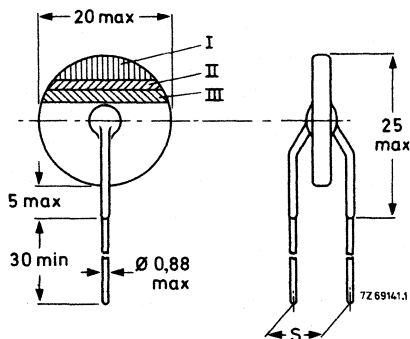

Fig. 1  $S = 9 \text{ mm}$  for types with C values up to 500.  $S = 10 \text{ mm}$  for others, see table.

**Marking**

A three-band colour code as shown in Fig. 1. This code indicates the three figures following the zero in the last part of the catalogue number shown in Table 1. The colours are in accordance with the standard VDR resistor colour code, e.g. type 2322 553 01161 is coded brown, brown, blue (100 mA, 8 V). See Table 2.

**Mass**

See Table 1.

**Mounting**

In any position by soldering.

**Robustness of terminations**

Tensile strength 20 N  
Bending 10 N

**Soldering**

Resistance to heat max. 240 °C, max. 4 s

**ELECTRICAL DATA**

Tolerance on voltage at  $I_{nom}$   $\pm 20\%$

Maximum dissipation 1 W

Asymmetry max. 2 %

**Operating temperature range**

zero power -25 to +125 °C  
max. power 0 to + 55 °C

See further Table 1.

**PACKAGING**

100 resistors in a cardboard box.

Table 1 Catalogue numbers 2322 553 0....

suffix of catalogue number 20% on V	d.c. current $I_{nom}$ mA	voltage at $I_{nom}$ V	$\beta$	C approx.	mass g	S max (Fig. 1) mm
1161	100	8	0,25 to 0,40	14	1,7	9
1181	100	10	0,25 to 0,40	18	1,8	9
1201	100	12	0,25 to 0,40	21	1,9	9
1221	100	15	0,25 to 0,40	26	1,9	9
2181	10	10	0,25 to 0,40	32	1,9	9
2201	10	12	0,25 to 0,40	40	2,0	9
2221	10	15	0,25 to 0,40	48	2,0	9
2241	10	18	0,21 to 0,35	57	2,0	9
2261	10	22	0,21 to 0,35	60	2,1	9
2281	10	27	0,21 to 0,35	70	2,1	9
2301	10	33	0,18 to 0,25	85	2,1	9
2321	10	39	0,18 to 0,25	100	2,1	9
2341	10	47	0,18 to 0,25	130	2,1	9
2361	10	56	0,18 to 0,25	150	2,1	9
2381	10	68	0,18 to 0,25	180	2,1	9
2401	10	82	0,14 to 0,23	190	2,1	9
3381	1	68	0,14 to 0,23	230	2,1	9
3401	1	82	0,14 to 0,21	300	2,1	9
3421	1	100	0,14 to 0,21	350	2,3	9
3441	1	120	0,14 to 0,21	400	2,4	9
3461	1	150	0,14 to 0,21	500	2,6	9
3481	1	180	0,14 to 0,21	600	2,9	10
3501	1	220	0,14 to 0,21	750	3,3	10
3521	1	270	0,14 to 0,21	900	3,7	10
3541	1	330	0,14 to 0,21	1100	4,2	10

Table 2.

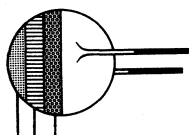

brown = 100 mA  
red = 10 mA  
orange = 1 mA

brown/blue	= 8 V	orange/blue	= 56 V
brown/grey	= 10 V	orange/grey	= 68 V
red/black	= 12 V	yellow/black	= 82 V
red/red	= 15 V	yellow/red	= 100 V
red/yellow	= 18 V	yellow/yellow	= 120 V
red/blue	= 22 V	yellow/blue	= 150 V
red/grey	= 27 V	yellow/grey	= 180 V
orange/black	= 33 V	green/black	= 220 V
orange/red	= 39 V	green/red	= 270 V
orange/yellow	= 47 V	green/yellow	= 330 V

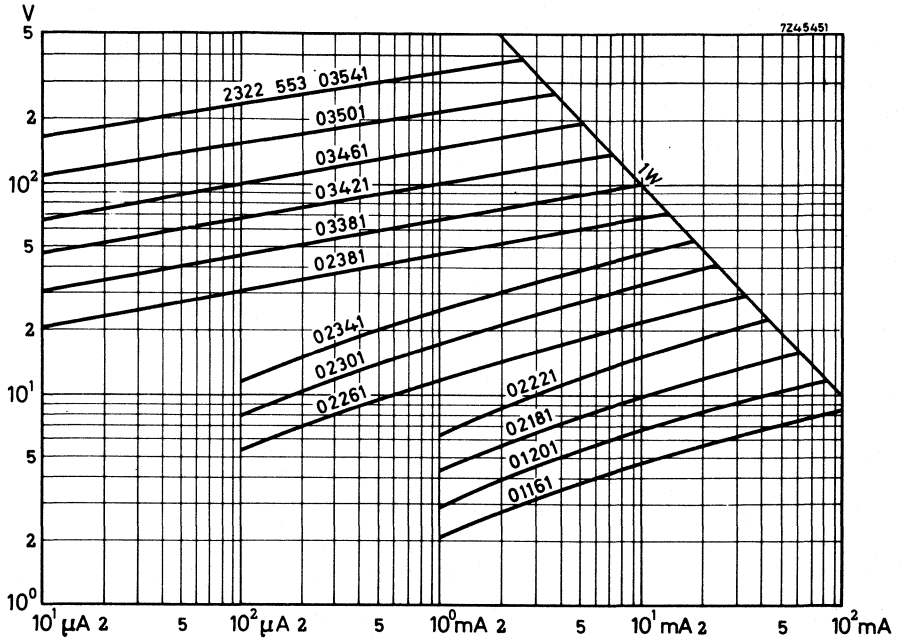

Fig. 2 Voltage/current characteristics.



## VOLTAGE DEPENDENT RESISTORS

silicon carbide disc

### QUICK REFERENCE DATA

#### D.C. voltage

$I_{nom} = 100 \text{ mA}$

8 to 18 V

$I_{nom} = 10 \text{ mA}$

12 to 180 V

$I_{nom} = 1 \text{ mA}$

150 to 330 V

$\beta$  between  $0,3 I_{nom}$  and  $3 I_{nom}$

0,14 to 0,40

Maximum dissipation

2 W

Operating temperature range

zero power

-25 to +125 °C

max. power

0 to + 55 °C

### APPLICATION

Voltage stabilization, contact protection and spark suppression.

### DESCRIPTION

A disc of silicon carbide with axial tinned copper leads. The disc is coated with tan coloured lacquer. It is not insulated.

### MECHANICAL DATA

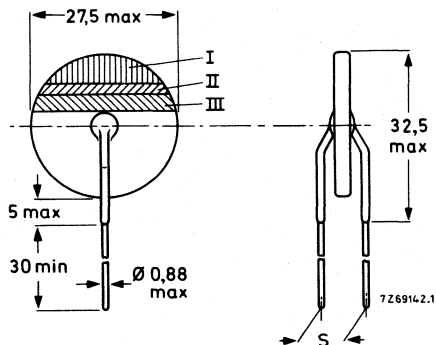

Fig. 1  $S = 9 \text{ mm}$  for types with C values up to 660.  $S = 10 \text{ mm}$  for others, see table.

**Marking**

A three-band colour code as shown in Fig. 1. This code indicates the three figures following the zero in the last part of the catalogue number shown in Table 1. The colours are in accordance with the standard VDR resistor colour code, e.g. type 2322 554 01161 is coded brown, brown, blue (100 mA, 8 V). See Table 2.

**Mass**

See Table 1.

**Mounting**

In any position by soldering.

**Robustness of terminations**

Tensile strength 20 N  
Bending 10 N

**Soldering**

Resistance to heat max. 240 °C, max. 4 s

**ELECTRICAL DATA**

Tolerance on voltage at  $I_{nom}$   $\pm 20\%$   
Maximum dissipation 2 W  
Asymmetry max. 2 %  
Operating temperature range  
zero power -25 to +125 °C  
max. power 0 to + 55 °C

See further Table 1.

**PACKAGING**

50 resistors in a cardboard box.

Table 1 Catalogue numbers 2322 554 0....

suffix of catalogue number 20% on V	d.c. current $I_{nom}$ mA	voltage at $I_{nom}$ V	$\beta$	C approx.	mass g	S max (Fig. 1) mm
1161	100	8	0,25 to 0,40	14	2,9	9
1181	100	10	0,25 to 0,40	18	2,95	9
1201	100	12	0,25 to 0,40	21	3,0	9
1221	100	15	0,25 to 0,40	26	3,0	9
1241	100	18	0,25 to 0,40	32	3,05	9
2201	10	12	0,25 to 0,40	38	3,05	9
2221	10	15	0,25 to 0,40	47	3,1	9
2241	10	18	0,21 to 0,35	57	3,1	9
2261	10	22	0,21 to 0,35	60	3,2	9
2281	10	27	0,21 to 0,35	70	3,3	9
2301	10	33	0,18 to 0,25	84	3,4	9
2321	10	39	0,18 to 0,25	97	3,45	9
2341	10	47	0,18 to 0,25	125	3,5	9
2361	10	56	0,18 to 0,25	140	3,55	9
2381	10	68	0,18 to 0,25	175	3,6	9
2401	10	82	0,14 to 0,23	170	3,65	9
2421	10	100	0,14 to 0,23	210	3,7	9
2441	10	120	0,14 to 0,21	250	3,75	9
2461	10	150	0,14 to 0,21	320	3,8	9
2481	10	180	0,14 to 0,21	380	4,2	9
3461	1	150	0,14 to 0,21	450	4,6	9
3481	1	180	0,14 to 0,21	540	5,2	9
3501	1	220	0,14 to 0,21	660	5,7	9
3521	1	270	0,14 to 0,21	810	5,7	10
3541	1	330	0,14 to 0,21	980	6,0	10

Table 2.

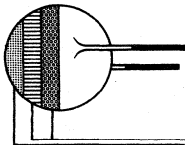

brown = 100 mA  
red = 10 mA  
orange = 1 mA

brown/blue	= 8 V	orange/blue	= 56 V
brown/grey	= 10 V	orange/grey	= 68 V
red/black	= 12 V	yellow/black	= 82 V
red/red	= 15 V	yellow/red	= 100 V
red/yellow	= 18 V	yellow/yellow	= 120 V
red/blue	= 22 V	yellow/blue	= 150 V
red/grey	= 27 V	yellow/grey	= 180 V
orange/black	= 33 V	green/black	= 220 V
orange/red	= 39 V	green/red	= 270 V
orange/yellow	= 47 V	green/yellow	= 330 V

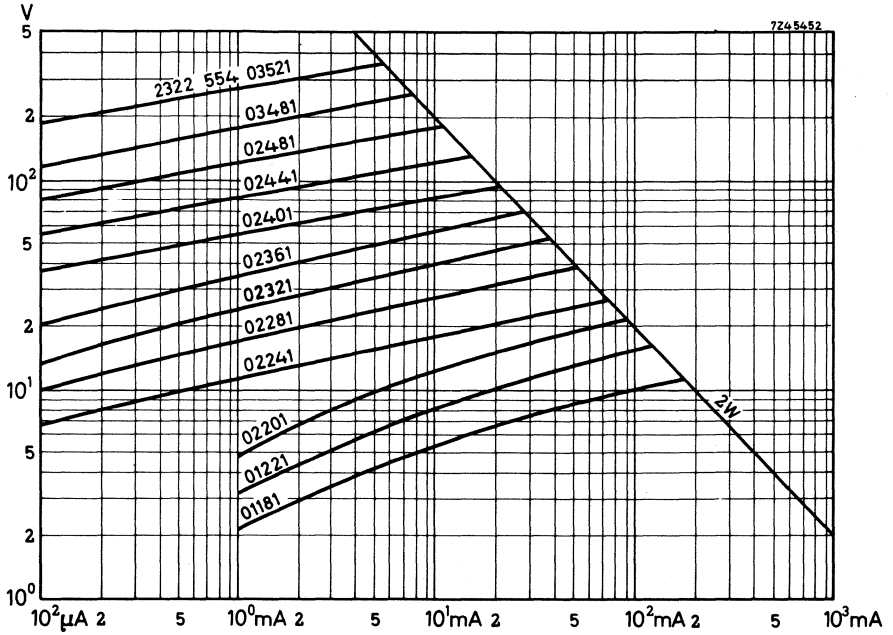

Fig. 2 Voltage/current characteristics.



## VOLTAGE DEPENDENT RESISTORS

silicon carbide disc

### QUICK REFERENCE DATA

D.C. voltage

$I_{nom} = 100 \text{ mA}$

8 to 33 V

$I_{nom} = 10 \text{ mA}$

22 to 270 V

$I_{nom} = 1 \text{ mA}$

220 to 330 V

$\beta$  between  $0,3 I_{nom}$  and  $3 I_{nom}$

0,14 to 0,40'

Maximum dissipation

3 W

Operating temperature range

zero power

-25 to +125 °C

max. power

0 to + 55 °C

### APPLICATION

Voltage stabilization, contact protection and spark suppression.

### DESCRIPTION

A disc of silicon carbide with axial tinned copper leads. The disc is coated with tan coloured lacquer. It is not insulated.

### MECHANICAL DATA

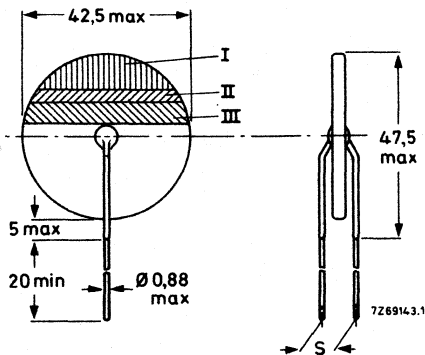

Fig. 1 For S see Table 1.

**Marking**

A three-band colour code as shown in Fig. 1. This code indicates the three figures following the zero in the last part of the catalogue number shown in Table 1. The colours are in accordance with the standard VDR resistor colour code, e.g. type 2322 555 01161 is coded brown, brown, blue (100 mA, 8 V). See Table 2.

**Mass**

See Table 1.

**Mounting**

In any position by soldering.

**Robustness of terminations**

Tensile strength	20 N
Bending	10 N

**Soldering**

Resistance to heat max. 240 °C, max. 4 s

**ELECTRICAL DATA**

Tolerance on voltage at  $I_{nom}$   $\pm 20\%$

Maximum dissipation 3 W

Asymmetry max. 2 %

**Operating temperature range**

zero power -25 to +125 °C

max. power 0 to + 55 °C

See further Table 1.

**PACKAGING**

25 resistors in a cardboard box.

Table 1 Catalogue numbers 2322 555 0....

suffix of catalogue number 20% on V	d.c. current $I_{nom}$ mA	voltage at $I_{nom}$ V	$\beta$	C approx.	mass g	S max (Fig. 1) mm
1161	100	8	0,25 to 0,40	14	8	9
1181	100	10	0,25 to 0,40	18	8	9
1201	100	12	0,25 to 0,40	21	8	9
1221	100	15	0,25 to 0,40	26	8	9
1241	100	18	0,25 to 0,40	32	8	9
1261	100	22	0,25 to 0,40	39	8	9
1281	100	27	0,25 to 0,40	48	8	9
1301	100	33	0,21 to 0,35	53	8	9
2261	10	22	0,21 to 0,35	60	8	9
2281	10	27	0,21 to 0,35	70	8	9
2301	10	33	0,18 to 0,25	84	8	9
2321	10	39	0,18 to 0,25	97	8	9
2341	10	47	0,18 to 0,25	125	10	9
2361	10	56	0,18 to 0,25	140	10	9
2381	10	68	0,18 to 0,25	175	10	9
2401	10	82	0,14 to 0,23	170	10	9
2421	10	100	0,14 to 0,23	210	10	9
2441	10	120	0,14 to 0,21	250	10	9
2461	10	150	0,14 to 0,21	320	10	9
2481	10	180	0,14 to 0,21	380	10	9
2501	10	220	0,14 to 0,21	460	10	10
2521	10	270	0,14 to 0,21	550	10	10
3501	1	220	0,14 to 0,21	660	10	10
3521	1	270	0,14 to 0,21	810	10	10
3541	1	330	0,14 to 0,21	980	10	11



Table 2.

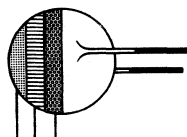

brown = 100 mA  
red = 10 mA  
orange = 1 mA

brown/blue = 8 V	orange/blue = 56 V
brown/grey = 10 V	orange/grey = 68 V
red/black = 12 V	yellow/black = 82 V
red/red = 15 V	yellow/red = 100 V
red/yellow = 18 V	yellow/yellow = 120 V
red/blue = 22 V	yellow/blue = 150 V
red/grey = 27 V	yellow/grey = 180 V
orange/black = 33 V	green/black = 220 V
orange/red = 39 V	green/red = 270 V
orange/yellow = 47 V	green/yellow = 330 V

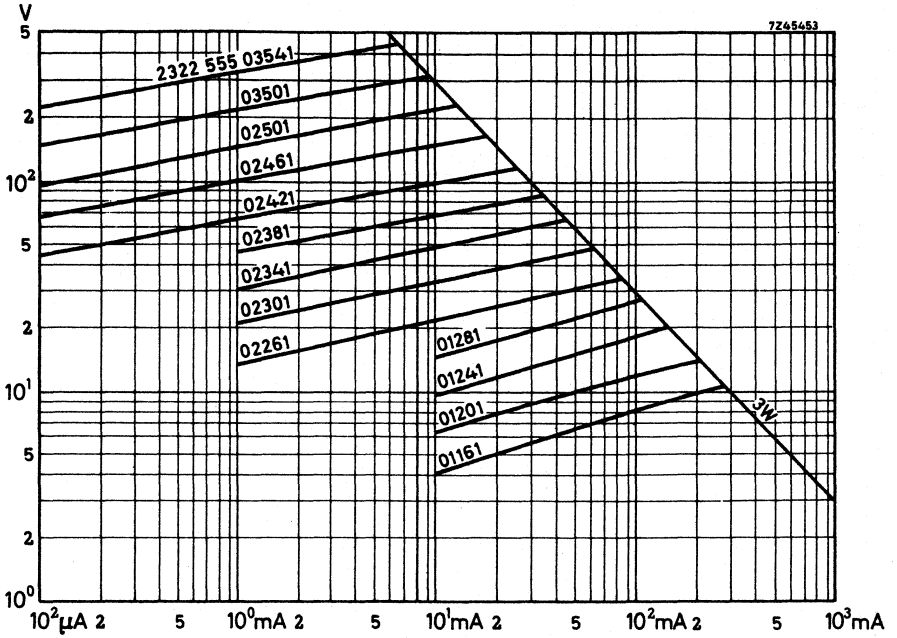

Fig. 2 Voltage/current characteristics.

## VOLTAGE DEPENDENT RESISTORS

silicon carbide rod

### QUICK REFERENCE DATA

D.C. voltage	
$I_{nom} = 10 \text{ mA}$	470 to 1300 V
$I_{nom} = 2 \text{ mA}$	950 V
$I_{nom} = 1 \text{ mA}$	300 V
$\beta$ -values	0,16 to 0,25
Maximum dissipation	0,8 W
Operating temperature range	
zero power	-25 to +125 °C
max. power	0 to + 55 °C

### APPLICATION

Voltage stabilization, contact protection, etc.

### DESCRIPTION

A rod of silicon carbide with axial tinned copper leads. The rod is coated with tan coloured lacquer. It is not insulated.

### MECHANICAL DATA

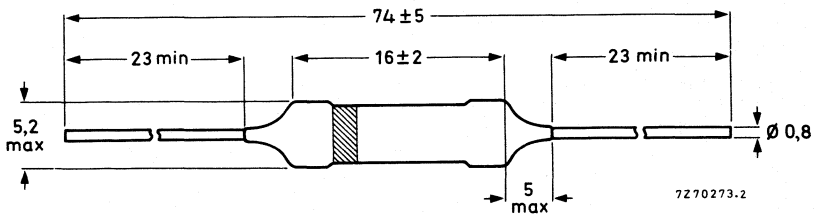

Fig. 1.

### Marking

The thermistors are colour coded according to the table and Fig. 1.

### Mass

0,9 g approximately

### Mounting

In any position by soldering

2322 564 02 ...  
2322 564 90 ...

### Robustness of terminations

Tensile strength 20 N  
Bending 10 N  
Torsion 3 times

### Soldering

Solderability max. 240 °C, max. 4 s  
Resistance to heat max. 265 °C, max. 11 s

### ELECTRICAL DATA

catalogue number	d.c. current $I_{nom}$ mA	voltage at $I_{nom}$ V*	tolerance on V %	$\beta$ -value	colour code (see Fig. 1)
2322 564 02582	10	470	± 10	0,20-0,25	green
2322 564 02602	10	560	± 10	0,18-0,23	blue
2322 564 02622	10	680	± 10	0,18-0,23	violet
2322 564 02681	10	1200	± 20	0,17-0,22	grey
2322 564 02682	10	1200	± 10	0,17-0,22	brown
2322 564 90014	10	910	± 10	0,17-0,22	white
2322 564 90015	10	1300	± 10	0,16-0,21	red
2322 564 90016	1	300	± 20	0,18-0,25	yellow

Dissipation factor 20 mW/K  
Temperature coefficient at 1 mA  
between +25 and +100 °C -0,1%/K  
Maximum dissipation 0,8 W  
Asymmetry \*\* max. 2%  
Operating temperature range  
at zero power -25 to +125 °C  
at maximum power 0 to + 55 °C

### → PACKAGING

250 resistors in a cardboard box.

\* The voltage is so measured, that the internal heat development is negligible.

\*\* Covered by the specified voltage tolerance.

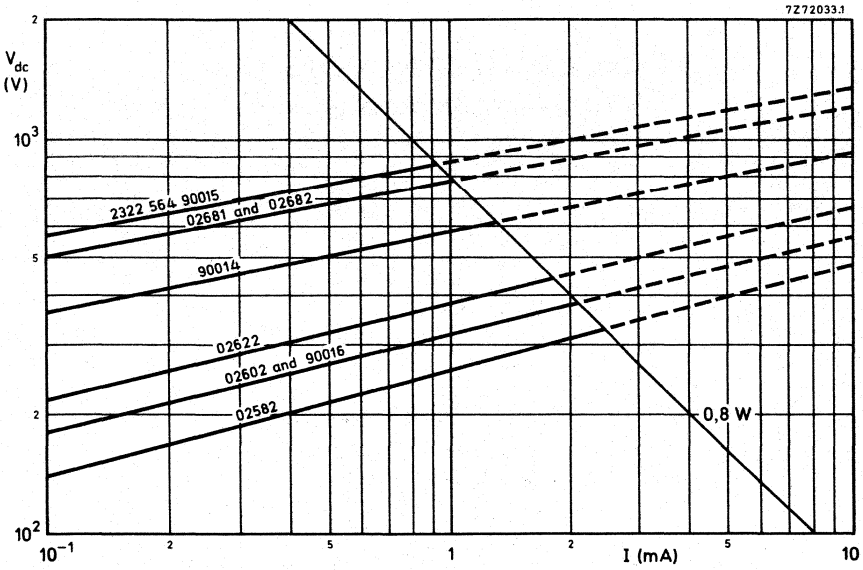
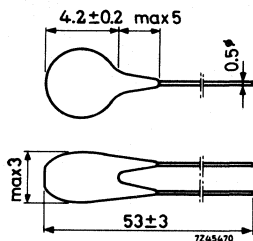

Fig. 2 Voltage/current characteristics.



## VOLTAGE DEPENDENT RESISTORS

small disc types for special purposes



Type 2322 565 90001 has been developed for use in small battery motors, for example. It can be mounted in the rotor to protect the collector and to suppress interference to radio and television.

Current at 5 V d.c.  $\leq 1$  mA

Current at 28 V d.c.  $\geq 10$  mA

$W_{\max}$  0,1 W

A special range of VDR discs has been developed for use in colour television.

I mA	E V	tolerance on voltage	colour dip code	catalogue number
1	6	$\pm 20\%$	red	2322 565 90002
1	9	$\pm 20\%$	orange	2322 565 90003
1	12	$\pm 15\%$	yellow	2322 565 90004
1	15	$\pm 15\%$	green	2322 565 90005
1	18	$\pm 12\%$	blue	2322 565 90006



## VOLTAGE DEPENDENT RESISTORS

titanium oxide disc

### QUICK REFERENCE DATA

Voltage at 1 mA d.c.	2,7 to 68 V
$\beta$ between 1 mA and 10 mA	max. 0,28
Maximum dissipation	0,25 W
Operating temperature range at zero power	-25 to +85 °C
at maximum power	0 to +55 °C

### APPLICATION

Intended for applications requiring a low  $\beta$ -value at a low voltage.

### DESCRIPTION

A titanium oxide disc with axial tinned copper leads. The disc is coated with tan coloured lacquer. It is not insulated.

### MECHANICAL DATA

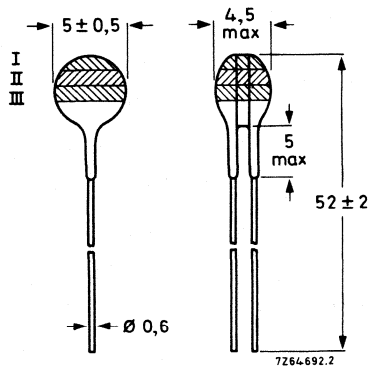

Fig. 1.

**Marking**

A three-band colour code as shown in Fig. 1. This code indicates the three figures following the zero in the last part of the catalogue number shown in Table 1. The colours are in accordance with the standard VDR resistor colour code, e.g. type 2322 581 03041 is coded orange, black, yellow (1 mA, 2,7 V). See Table 2.

**Mass**

0,4 g approximately

**Mounting**

In any position by soldering.

**Robustness of terminations**

Tensile strength	10 N
Bending	5 N

**Soldering**

Solderability	max. 240 °C, max. 4 s
Resistance to heat	260 ± 5 °C, max. 10 s

**Impact**

Free fall	1000 mm
-----------	---------

**Resistance to solvents**

Resist to freon TMC and trichlorotrifluoroethane 70% + isopropyl alcohol 30%.

**ELECTRICAL DATA**

Tolerance on voltage at 1 mA	± 20% and ± 10%
Temperature coefficient measured at 10 mA between +25 and +55 °C	-0,25%/K
Dissipation factor	7 mW/K approx.
Maximum dissipation	0,25 W
Asymmetry	max. 2%
Operating temperature range zero power	-25 to +85 °C
maximum power	0 to +55 °C

**PACKAGING**

250 resistors in a cardboard box.

\* The 10% types have an extra silver tipping.

Table 1 Catalogue numbers 2322 581 0....

suffix of catalogue number 20% on V *	d.c. voltage at 1 mA	max. peak current (8 x 20 μs)	protection level (max. clamping voltage at 10 A) for +20% at V at 1 mA	β between 1-10 mA	capacitance at 10 kHz
	V	A	V		nF
03041	2,7	315	40	0,28	40
03061	3,3	300	42	0,28	35
03081	3,9	290	45	0,28	29
03101	4,7	275	48	0,25	24
03121	5,6	265	52	0,25	21
03141	6,8	250	58	0,22	18
03161	8,2	240	64	0,22	16
03181	10	225	72	0,22	14
03201	12	215	82	0,22	12
03221	15	210	96	0,22	11
03241	18	195	110	0,22	9,5
03261	22	185	125	0,20	8
03281	27	175	200	0,20	7
03301	33	165	235	0,20	5,5
03321	39	155	270	0,20	5
03341	47	150	315	0,20	4
03361	56	145	370	0,20	3
03381	68	135	430	0,20	2

\* For a 10% tolerance on voltage replace last digit (1) in the catalogue number by a 2.

Table 2

VDR standard

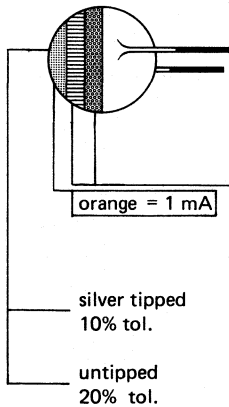

black/yellow	= 2,7 V	red/red	= 15 V
black/blue	= 3,3 V	red/yellow	= 18 V
black/grey	= 3,9 V	red/blue	= 22 V
brown/black	= 4,7 V	red/grey	= 27 V
brown/red	= 5,6 V	orange/black	= 33 V
brown/yellow	= 6,8 V	orange/red	= 39 V
brown/blue	= 8,2 V	orange/yellow	= 47 V
brown/grey	= 10 V	orange/blue	= 56 V
red/black	= 12 V	orange/grey	= 68 V

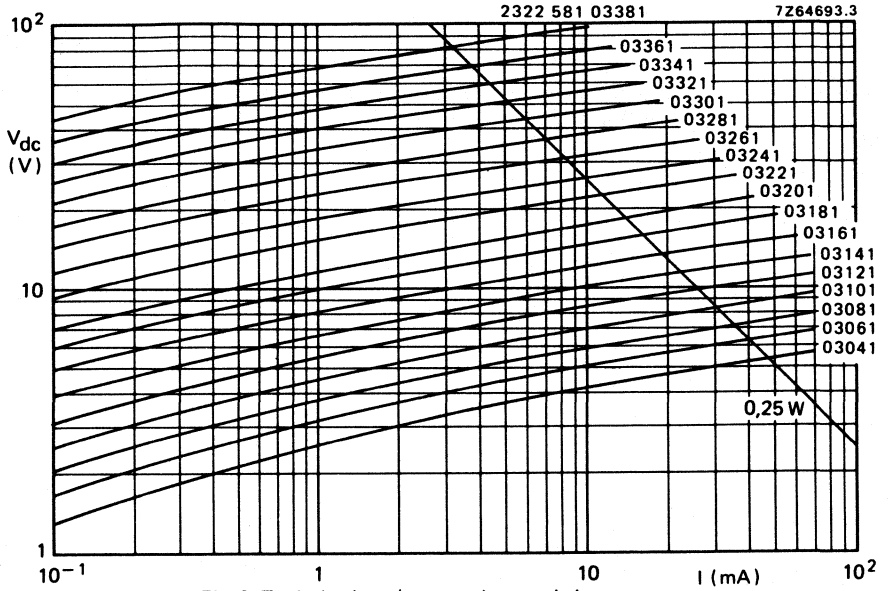

Fig. 2 Typical voltage/current characteristics.

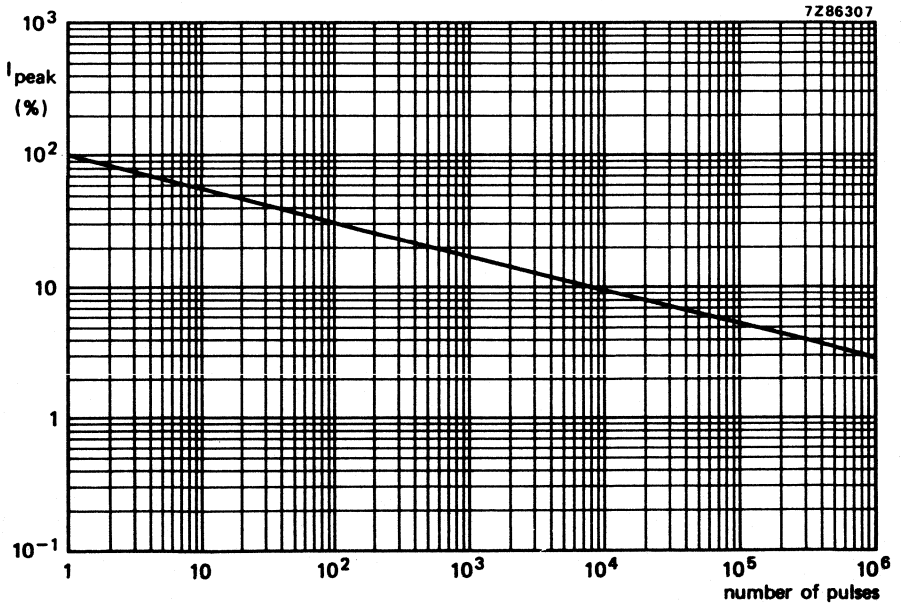

Fig. 3 Maximum applicable transient current.

## VOLTAGE-DEPENDENT RESISTORS

zinc oxide disc

### QUICK REFERENCE DATA

Maximum a.c. voltage (r.m.s.)	60 to 460 V
Maximum d.c. voltage	85 to 615 V
Maximum non-repetitive transient current (8/20 $\mu$ s)	400 A
Climatic category	40/125/56
Packaging	
2322 592 3....	in tape on reel
2322 592 6....	in bulk in box

### APPLICATION

Suppression of transients, contact protection, spark suppression, suppression of line transients in telephony.

### DESCRIPTION

A disc of low- $\beta$  ceramic with two solid tinned copper wires. The VDRs are lacquered, but not insulated.

### MECHANICAL DATA

Dimensions in mm

#### Outlines

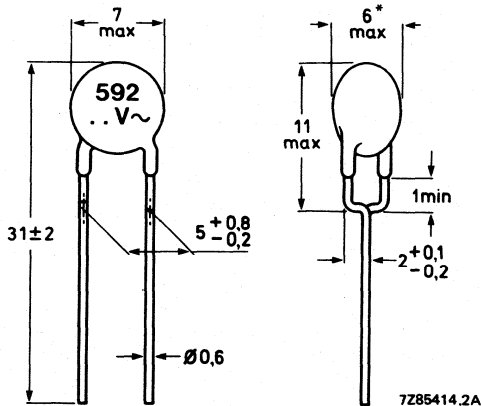

Fig. 1.

\*The device thickness is dependent upon the r.m.s. working voltage rating.

2322 592 3....

2322 592 6....

### Marking

The resistors are marked with their serial number (592) and the maximum r.m.s. working voltage (see Fig. 1 and Table 1).

### Mass

Approx. 0,5 g.

### Mounting

In any position by soldering. Leads should be as short as possible. The VDR should be mounted near the equipment or component to be protected.

### Robustness of terminations

Tensile strength 10 N

Bending 5 N

### Soldering

Solderability max. 240 °C, max. 4 s

Resistance to heat  $260 \pm 5$  °C;  $10 \pm 1$  s

### Impact

Free fall 1000 mm

### Resistance to solvents

According to IEC 68-2-45, resist to R113

### Inflammability

Self-extinguishing according to IEC draft 50D, severity 10 s

### ELECTRICAL DATA

Unless otherwise specified all electrical values apply at an ambient temperature of  $+23 \pm 1$  °C

Thermal resistance, body to air approx. 80 K/W

Temperature coefficient at 1 mA,  
measured between  $+25$  and  $+85$  °C max.  $-0,065$  %/K

Maximum average dissipation  
(including transients) 100 mW

Maximum non-repetitive transient current (8/20  $\mu$ s) (note 5) 400 A

Climatic category 40/125/56

See further Table 1

Table 1 Catalogue numbers 2322 592 3.... and 2322 592 6....

suffix of catalogue number	MAXIMUM RATINGS				CHARACTERISTICS			
	r.m.s. working voltage (notes 3,4)	d.c. working voltage (note 3)	transient energy (notes 5, 6)		varistor voltage $\pm 10\%$ (note 1)		maximum clamping voltage at 50 A (note 2)	typical capacitance at 1 kHz
			8/20 $\mu\text{s}$	10/1000 $\mu\text{s}$	min.	max.		
	V	V	J	J	V	V	V	pF
6002	60	85	2,3	2,7	90	110	220	190
7502	75	100	2,6	3,5	108	132	240	160
9502	95	125	3,0	4,0	135	165	295	130
1312	130	170	4,5	5,5	185	225	405	100
1512	150	200	5,0	6,5	216	264	470	90
1712	175	225	5,5	7,0	243	297	525	80
2312	230	300	7,0	9,0	324	396	675	70
2512	250	320	7,5	10,0	351	429	745	60
2712	275	350	8,5	11,0	387	473	820	60
3012	300	385	9,5	12,0	423	517	905	50
4212	420	560	14,0	17,0	612	748	1340	50
4612	460	615	16,0	20,0	675	825	1480	50

**Notes**

1. Voltage at a current of 1 mA, after an impulse time of 50 ms with a rise time of 10  $\mu\text{s}$  to 1 ms.
2. Measured with a standard impulse current 8/20  $\mu\text{s}$ , defined in IEC 60-2 section 6, par. 16-1.
3. Derating, see Fig. 4.
4. Sinusoidal voltage assumed. For a non-sinusoidal voltage, the crest voltage  $\times 0,707$  should be used for type selection.
5. A current impulse of 8/20  $\mu\text{s}$  (defined in IEC 60-2 section 6) is used as a standard for impulse current and clamping voltage ratings. The transient energy is given for one impulse applied during the life of the component. Figure 3 gives the derating for different numbers and longer duration of impulses. The shift of the varistor voltage does not exceed  $\pm 5\%$ .
6. High energy surges are generally of longer duration. The max. energy for 1 impulse 10/1000  $\mu\text{s}$  is given as a reference for long duration impulses. This impulse can be characterized by peak current  $I_p$  and impulse width  $t_2$  (virtual time to half  $I_p$  value, defined in IEC 60-2 section 6), see Fig. 5. If  $V_p$  is the clamping voltage corresponding to  $I_p$ , the energy absorbed in the VDR is determined by equation  $E = K \cdot V_p \cdot I_p \cdot t_2$ ; K depends on  $t_2$ . When  $t_1$  is 8 to 10  $\mu\text{s}$  and  $t_2 = 20 \mu\text{s}$ ,  $K = 1$ ; when  $t_2 = 50 \mu\text{s}$ ,  $K = 1,2$ ; when  $t_2 = 100 \mu\text{s}$ ,  $K = 1,3$ ; when  $t_2 = 1000 \mu\text{s}$ ,  $K = 1,4$ .

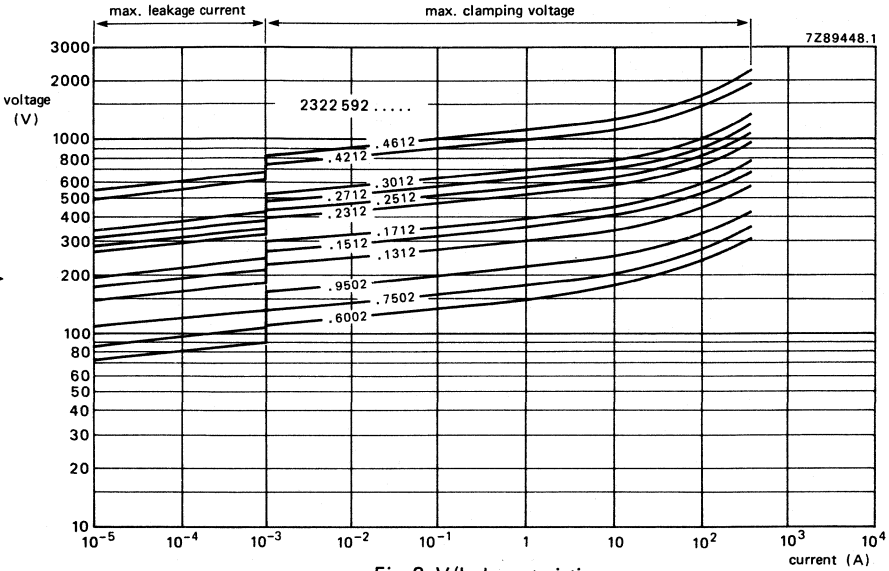

Fig. 2 V/I characteristics.

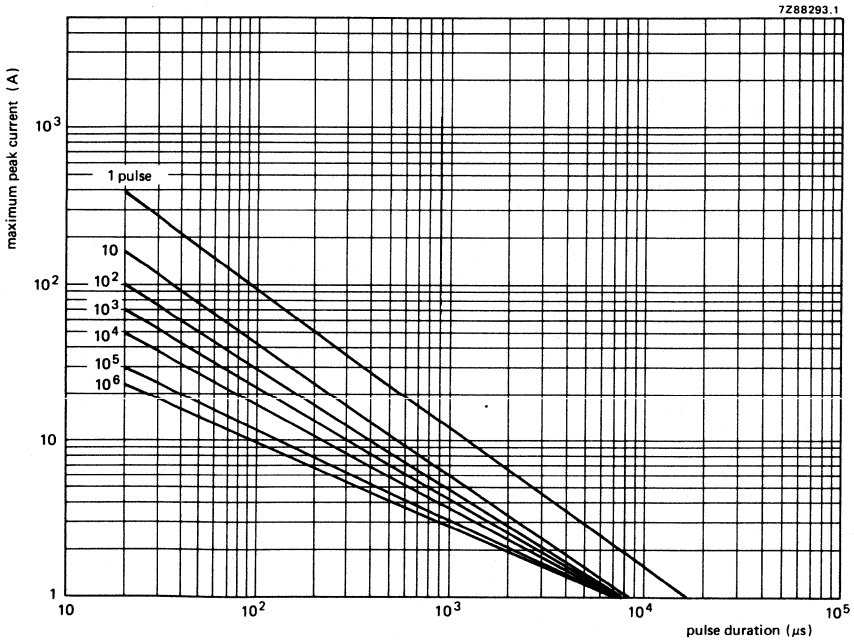

Fig. 3 Max. applicable transient current as a function of pulse duration.



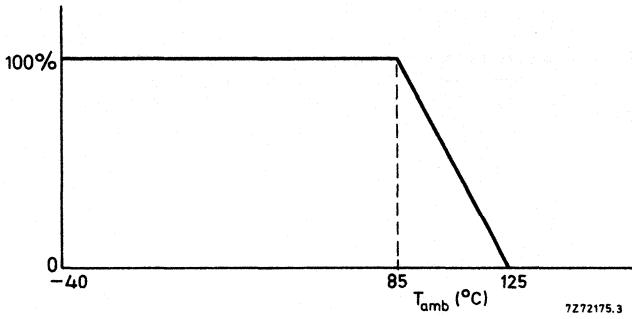

Fig. 4 Derating of max. d.c. and r.m.s. working voltage with temperature.

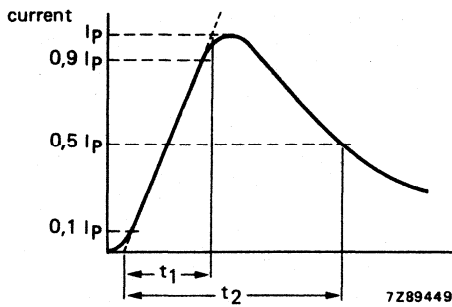

Fig. 5.

PACKAGING

Types 2322 592 3.... are supplied on tape on reel. A reel contains 1500 resistors.  
Types 2322 592 6.... are supplied in bulk, 500 resistors per cardboard box.

Configuration of the tape

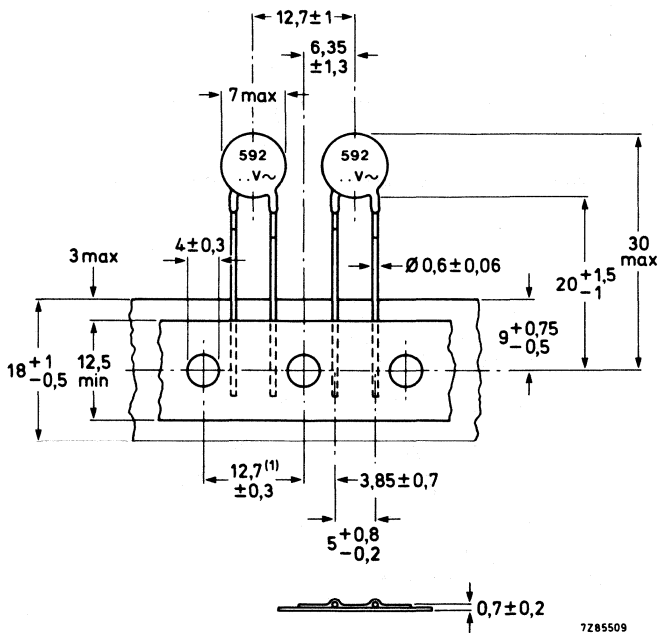

Fig. 6 Types 2322 592 3.... on tape.

(1) Cumulative pitch error: 1 mm/20 pitch.

## VOLTAGE-DEPENDENT RESISTORS

zinc oxide disc

### QUICK REFERENCE DATA

Maximum a.c. voltage (r.m.s.)	60 to 460 V
Maximum d.c. voltage	85 to 615 V
Maximum non-repetitive transient current (8/20 $\mu$ s)	1200 A
Climatic category	40/125/56
Packaging	
2322 593 3....	in tape on reel
2322 593 6....	in bulk in box



### APPLICATION

Suppression of transients, contact protection, spark suppression, suppression of line transients in telephony.

### DESCRIPTION

A disc of low- $\beta$  ceramic with two solid tinned copper wires. The VDRs are lacquered, but not insulated.

### MECHANICAL DATA

Dimensions in mm

#### Outlines

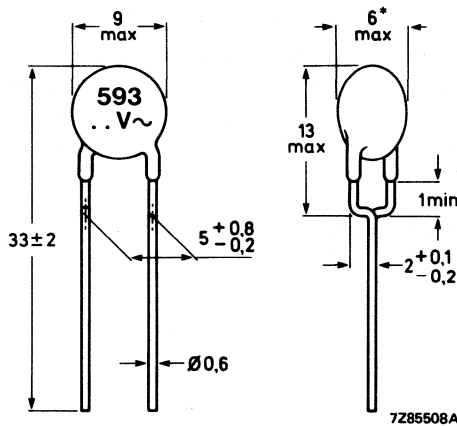

Fig. 1.

\*The device thickness is dependent upon the r.m.s. working voltage rating.

### Marking

The resistors are marked with their serial number (593) and the maximum r.m.s. working voltage (see Fig. 1 and Table 1).

### Mass

Approx. 0,7 g

### Mounting

In any position by soldering. Leads should be as short as possible. The VDR should be mounted near the equipment or component to be protected.

### Robustness of terminations

Tensile strength 10 N  
Bending 5 N

### Soldering

Solderability max. 240 °C, max. 4 s  
Resistance to heat 260 ± 5 °C; 10 ± 1 s

### Impact

Free fall 1000 mm

### Resistance to solvents

According to IEC 68-2-45, resist to R113 at 23 °C

### Inflammability

Self-extinguishing according to IEC 50D, severity 10 s

### ELECTRICAL DATA

Unless otherwise specified all electrical values apply at an ambient temperature of +23 ± 1 °C

Thermal resistance, body to air	approx.	70 K/W
Temperature coefficient at 1 mA, measured between +25 and +85 °C	max.	-0,065 %/K
Maximum average dissipation (including transients)		250 mW
Maximum non-repetitive transient current (8/20 μs) (note 5)		1200 A
Climatic category		40/125/56

See further Table 1

Table 1 Catalogue numbers 2322 593 3... and 2322 593 6....

suffix of catalogue number	MAXIMUM RATINGS				CHARACTERISTICS			
	r.m.s. working voltage (notes 3, 4)	d.c. working voltage (note 3)	transient energy (notes 5, 6)		varistor voltage $\pm 10\%$ (note 1)		maximum clamping voltage at 100 A (note 2)	typical capacitance at 1 kHz
			8/20 $\mu\text{s}$	10/1000 $\mu\text{s}$	min.	max.		
V	V	J	J	V	V	V	pF	
6002	60	85	6	4,6	90	110	210	600
7502	75	100	9	5,5	108	132	250	530
9502	95	125	9,5	7,0	135	165	310	460
1312	130	170	14	9,5	185	225	425	390
1512	150	200	17	11,0	216	264	485	340
1712	175	225	20	13,0	243	297	550	250
2312	230	300	22	16,0	324	396	720	190
2512	250	320	23	18,0	351	429	780	160
2712	275	350	26	20,0	387	473	850	140
3012	300	385	29	22,0	423	517	930	110
4212	420	560	42	30,0	612	748	1350	90
4612	460	615	48	32,0	675	825	1490	80

## Notes

- Voltage at a current of 1 mA, after an impulse time of 50 ms with a rise time of 10  $\mu\text{s}$  to 1 ms.
- Measured with a standard impulse current 8/20  $\mu\text{s}$ , defined in IEC 60-2 section 6, par. 16-1.
- Derating, see Fig. 4.
- Sinusoidal voltage assumed. For a non-sinusoidal voltage, the crest voltage  $\times 0,707$  should be used for type selection.
- A current impulse of 8/20  $\mu\text{s}$  (defined in IEC 60-2 section 6) is used as a standard for impulse current and clamping voltage ratings. The transient energy is given for one impulse applied during the life of the component. Figure 3 gives the derating for different numbers and longer duration of impulses. The shift of the varistor voltage does not exceed  $\pm 5\%$ .
- High energy surges are generally of longer duration. The max. energy for 1 impulse 10/1000  $\mu\text{s}$  is given as a reference for long duration impulses. This impulse can be characterized by peak current  $I_p$  and impulse width  $t_2$  (virtual time to half  $I_p$  value, defined in IEC 60-2 section 6), see Fig. 5. If  $V_p$  is the clamping voltage corresponding to  $I_p$ , the energy absorbed in the VDR is determined by equation  $E = K \cdot V_p \cdot I_p \cdot t_2$ ; K depends on  $t_2$ . When  $t_1$  is 8 to 10  $\mu\text{s}$  and  $t_2 = 20 \mu\text{s}$ ,  $K = 1$ ; when  $t_2 = 50 \mu\text{s}$ ,  $K = 1,2$ ; when  $t_2 = 100 \mu\text{s}$ ,  $K = 1,3$ ; when  $t_2 = 1000 \mu\text{s}$ ,  $K = 1,4$ .

2322 593 3....  
 2322 593 6....

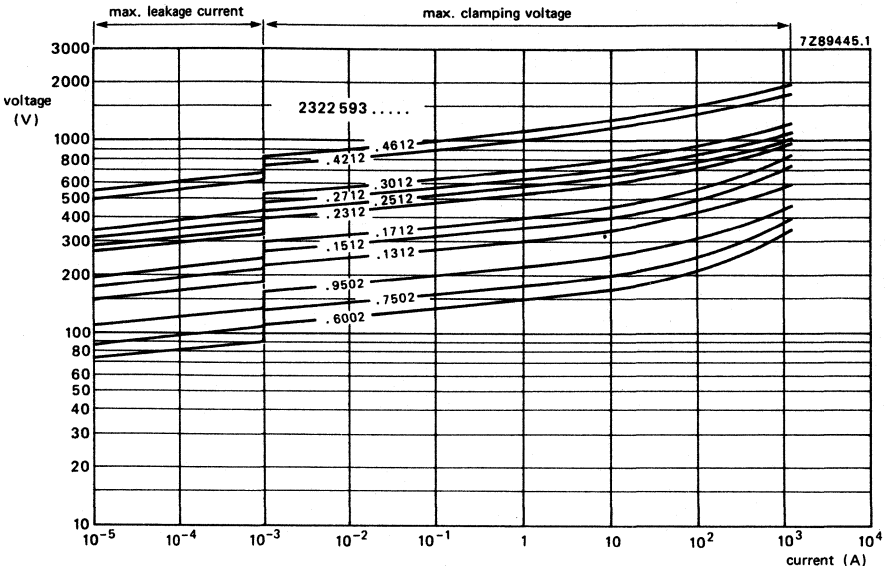

Fig. 2 V/I characteristics.

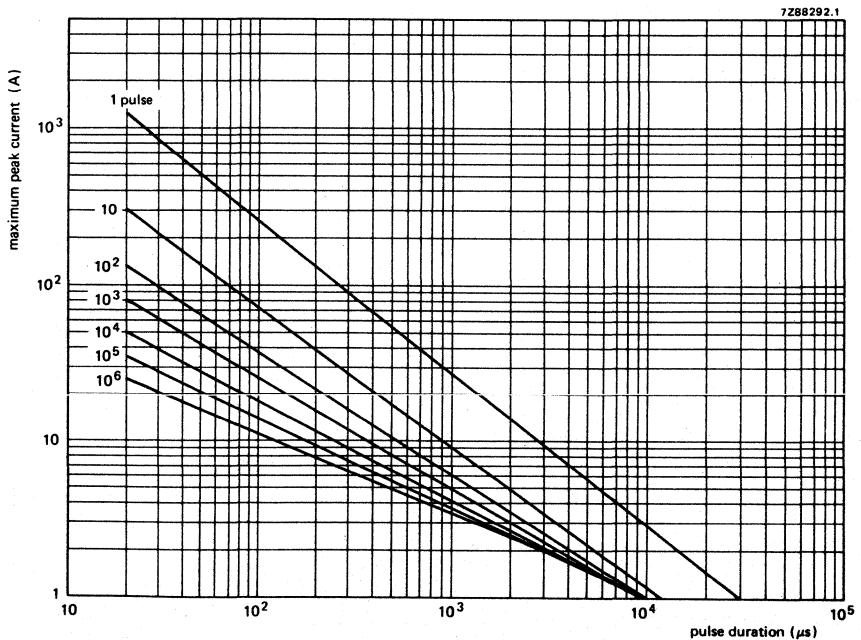

Fig. 3 Max. applicable transient current as a function of pulse duration.

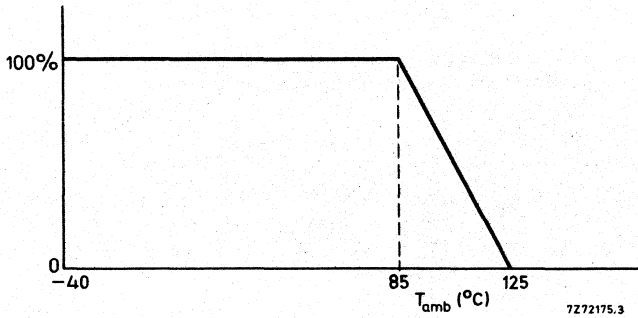

Fig. 4 Derating of max. d.c. and r.m.s. working voltage with temperature.

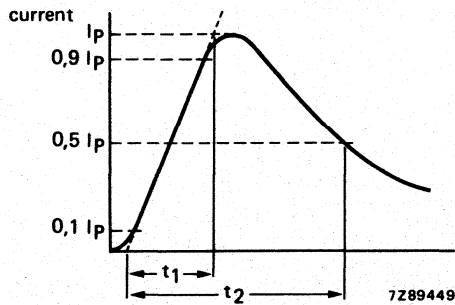

Fig. 5.



**PACKAGING**

Types 2322 593 3.... are supplied on tape on reel. A reel contains 1500 resistors.  
 Types 2322 593 6.... are supplied in bulk, 500 resistors per cardboard box.

Configuration of the tape

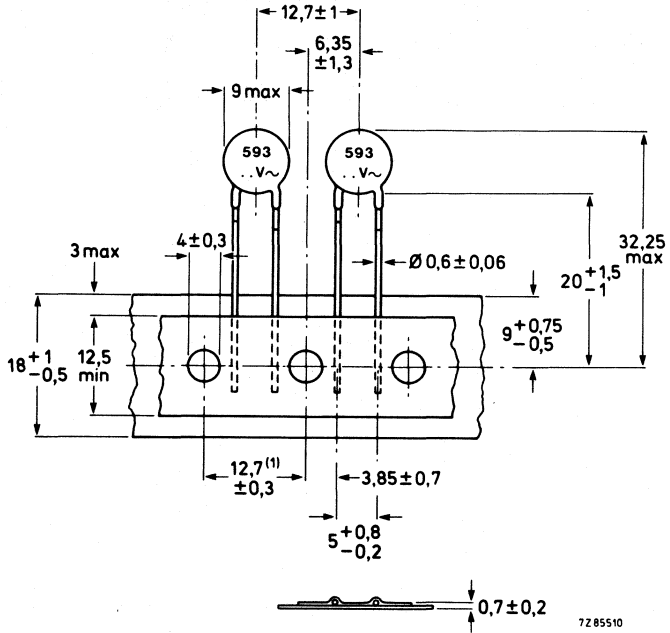

Fig. 6 Types 2322 593 3.... on tape.

(1) Cumulative pitch error: 1 mm/20 pitch.



## VOLTAGE-DEPENDENT RESISTORS

zinc oxide disc

### QUICK REFERENCE DATA

Maximum a.c. voltage (r.m.s.)	60 to 460 V
Maximum d.c. voltage	85 to 615 V
Maximum non-repetitive transient current (8/20 $\mu$ s)	2500 A
Climatic category	40/125/56
Packaging	in bulk in box

### APPLICATION

Suppression of transients, contact protection, spark suppression, suppression of line transients in telephony.

### DESCRIPTION

A disc of low- $\beta$  ceramic with two solid tinned copper wires. The VDRs are lacquered, but not insulated.

### MECHANICAL DATA

Dimensions in mm

#### Outlines

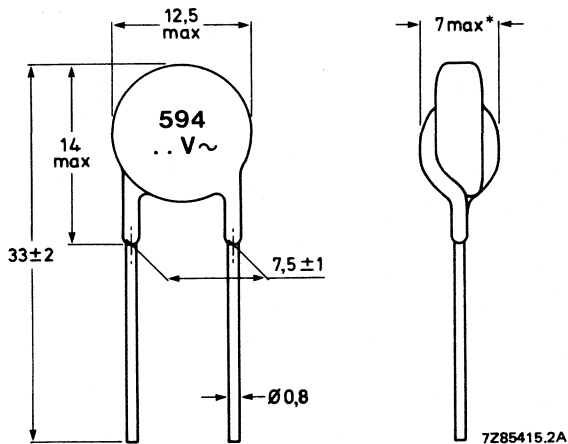

\*The device thickness is dependent upon the r.m.s. working voltage rating.

**Marking**

The resistors are marked with their serial number (594) and the maximum r.m.s. working voltage (see Fig. 1 and Table 1).

**Mass**

Approx. 1,5 g

**Mounting**

In any position by soldering. Leads should be as short as possible. The VDR should be mounted near the equipment or component to be protected.

**Robustness of terminations**

Tensile strength 10 N  
Bending 5 N

**Soldering**

Solderability max. 240 °C, max. 4 s.  
Resistance to heat 260 ± 5 °C; 10 ± 1 s

**Impact**

Free fall 1000 mm

**Resistance to solvents**

According to IEC 68-2-45, resist to R113 at 23 °C

**Inflammability**

Self-extinguishing according to IEC 50D, severity 10 s

**ELECTRICAL DATA**

Unless otherwise specified all electrical values apply at an ambient temperature of +23 ± 1 °C

Thermal resistance, body to air	approx.	60 K/W
Temperature coefficient at 1 mA, measured between +25 and +85 °C	max.	-0,065 %/K
Maximum average dissipation (including transients)		400 mW
Maximum non-repetitive transient current (8/20 μs) (note 5)		2500 A
Climatic category		40/125/56

See further Table 1

Table 1 Catalogue numbers 2322 594 6....

suffix of catalogue number	MAXIMUM RATINGS				CHARACTERISTICS			
	r.m.s. working voltage (notes 3,4)	d.c. working voltage (note 3)	transient energy (notes 5, 6)		varistor voltage $\pm 10\%$ (note 1)		maximum clamping voltage at 100 A (note 2)	typical capacitance at 1 kHz
			8/20 $\mu\text{s}$	10/1000 $\mu\text{s}$	min.	max.		
	V	V	J	J	V	V	V	pF
6002	60	85	18	8	90	110	185	1200
7502	75	100	21	10	108	132	225	1000
9502	95	125	25	12	135	165	285	900
1312	130	170	30	16	185	225	385	730
1512	150	200	35	18	216	264	455	600
1712	175	225	40	22	243	297	520	480
2312	230	300	50	29	324	396	686	360
2512	250	320	58	32	351	429	740	320
2712	275	350	61	35	387	473	815	290
3012	300	385	65	38	423	517	880	240
4212	420	560	85	54	612	748	1310	190
4612	460	615	96	59	675	825	1440	170

## Notes

1. Voltage at a current of 1 mA, after an impulse time of 50 ms with a rise time of 10  $\mu\text{s}$  to 1 ms.
2. Measured with a standard impulse current 8/20  $\mu\text{s}$ , defined in IEC 60-2 section 6, par. 16-1.
3. Derating, see Fig. 4.
4. Sinusoidal voltage assumed. For a non-sinusoidal voltage, the crest voltage  $\times 0,707$  should be used for type selection.
5. A current impulse of 8/20  $\mu\text{s}$  (defined in IEC 60-2 section 6) is used as a standard for impulse current and clamping voltage ratings. The transient energy is given for one impulse applied during the life of the component. Figure 3 gives the derating for different numbers and longer duration of impulses. The shift of the varistor voltage does not exceed  $\pm 5\%$ .
6. High energy surges are generally of longer duration. The max. energy for 1 impulse 10/1000  $\mu\text{s}$  is given as a reference for long duration impulses. This impulse can be characterized by peak current  $I_p$  and impulse width  $t_2$  (virtual time to half  $I_p$  value, defined in IEC 60-2 section 6), see Fig. 5. If  $V_p$  is the clamping voltage corresponding to  $I_p$ , the energy absorbed in the VDR is determined by equation  $E = K \cdot V_p \cdot I_p \cdot t_2$ ; K depends on  $t_2$ . When  $t_1$  is 8 to 10  $\mu\text{s}$  and  $t_2 = 20 \mu\text{s}$ ,  $K = 1$ ; when  $t_2 = 50 \mu\text{s}$ ,  $K = 1,2$ ; when  $t_2 = 100 \mu\text{s}$ ,  $K = 1,3$ ; when  $t_2 = 1000 \mu\text{s}$ ,  $K = 1,4$ .

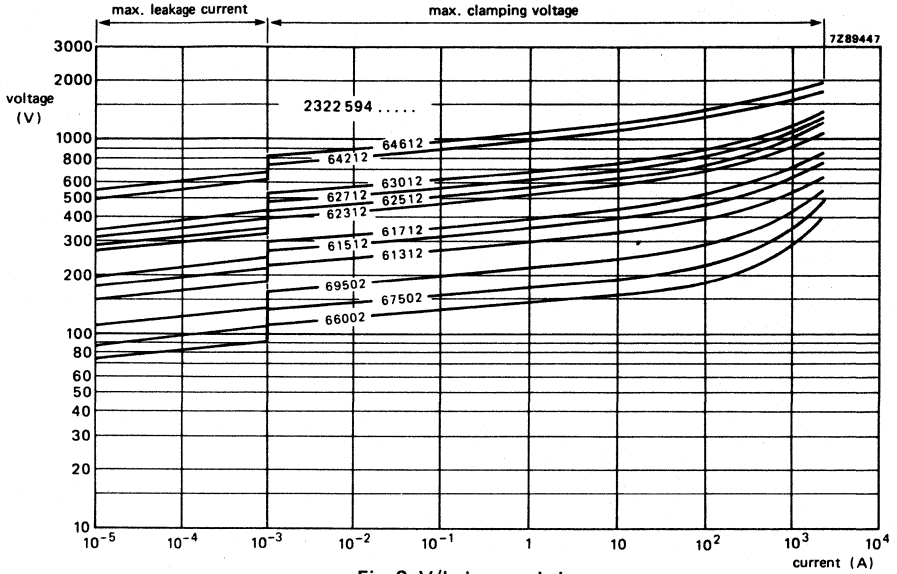

Fig. 2 V/I characteristics.

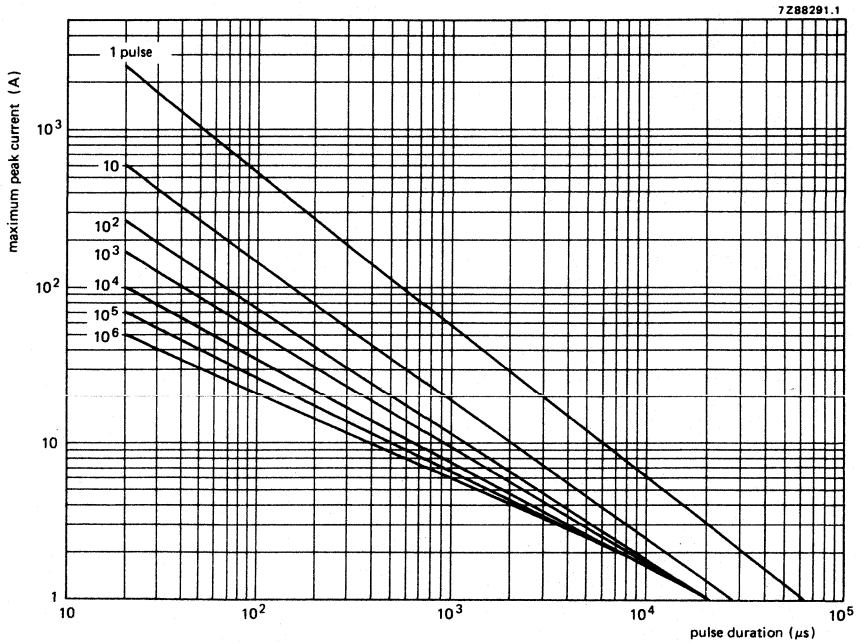

Fig. 3 Max. applicable transient current as a function of pulse duration.

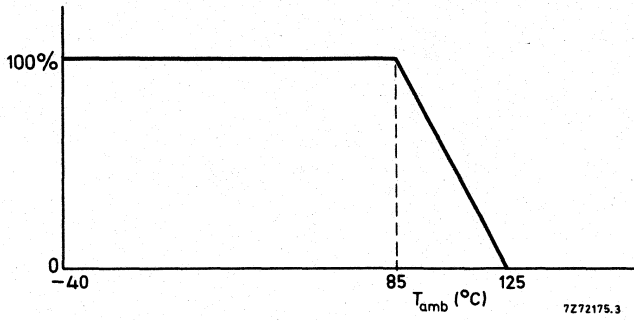

Fig. 4 Derating of max. d.c. and r.m.s. working voltage with temperature.

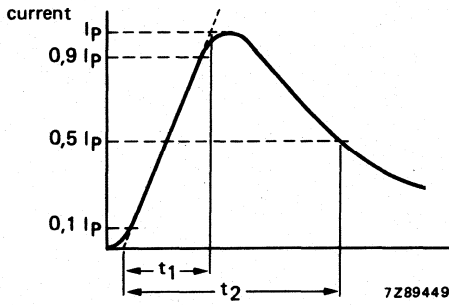

Fig. 5.

**PACKAGING**

The resistors 2322 594 6.... are supplied in bulk packing only in boxes of 250.



## VOLTAGE-DEPENDENT RESISTORS

zinc oxide disc

### QUICK REFERENCE DATA

Maximum a.c. voltage (r.m.s.)	60 to 460 V
Maximum d.c. voltage	85 to 615 V
Maximum non-repetitive transient current (8/20 $\mu$ s)	4500 A
Climatic category	40/125/56
Packaging	in bulk in box

### APPLICATION

Suppression of transients, contact protection, spark suppression, suppression of line transients in telephony.

### DESCRIPTION

A disc of low- $\beta$  ceramic with two solid tinned copper wires. The VDRs are lacquered, but not insulated.

### MECHANICAL DATA

Dimensions in mm

#### Outlines

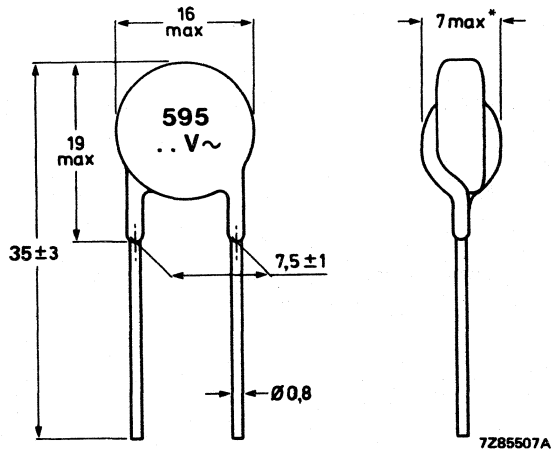

Fig. 1.

\*The device thickness is dependent upon the r.m.s. working voltage rating.

**Marking**

The resistors are marked with their serial number (595) and the maximum r.m.s. working voltage (see Fig. 1 and Table 1).

**Mass**

Approx. 2 g

**Mounting**

In any position by soldering. Leads should be as short as possible. The VDR should be mounted near the equipment or component to be protected.

**Robustness of terminations**

Tensile strength	10 N
Bending	5 N

**Soldering**

Solderability	max. 240 °C, max. 4 s
Resistance to heat	260 ± 5 °C; 10 ± 1 s

**Impact**

Free fall 1000 mm

**Resistance to solvents**

According to IEC 68-2-45, resist to R113, at 23 °C

**Inflammability**

Self-extinguishing according to IEC draft 50D, severity 10 s

**ELECTRICAL DATA**

Unless otherwise specified all electrical values apply at an ambient temperature of +23 ± 1 °C

Thermal resistance, body to air	approx.	50 K/W
Temperature coefficient at 1 mA, measured between +25 and +85 °C	max.	-0,065 %/K
Maximum average dissipation (including transients)		600 mW
Maximum non-repetitive transient current (8/20 μs) (note 5)		4500 A
Climatic category		40/125/56

See further Table 1



Table 1 Catalogue numbers 2322 595 6....

suffix of catalogue number	MAXIMUM RATINGS				CHARACTERISTICS			
	r.m.s. working voltage (notes 3,4)	d.c. working voltage (note 3)	transient energy (notes 5, 6)		varistor voltage $\pm 10\%$ (note 1)		maximum clamping voltage at 100 A (note 2)	typical capacitance at 1 kHz
			8/20 $\mu\text{s}$	10/1000 $\mu\text{s}$	min.	max.		
V	V	J	J	V	V	V	pF	
6002	60	85	27	12	90	110	175	2300
7502	75	100	34	14	108	132	210	1900
9502	95	125	42	19	135	165	270	1700
1312	130	170	53	26	185	225	360	1300
1512	150	200	61	30	216	264	415	1100
1712	175	225	70	35	243	297	480	920
2312	230	300	89	48	324	396	650	700
2512	250	320	98	51	351	429	695	630
2712	275	350	109	56	387	473	765	600
3012	300	385	116	61	423	517	835	520
4212	420	560	150	93	612	748	1225	400
4612	460	615	167	102	675	825	1342	380

## Notes

1. Voltage at a current of 1 mA, after an impulse time of 50 ms with a rise time of 10  $\mu\text{s}$  to 1 ms.
2. Measured with a standard impulse current 8/20  $\mu\text{s}$ , defined in IEC 60-2 section 6, par. 16-1.
3. Derating, see Fig. 4.
4. Sinusoidal voltage assumed. For a non-sinusoidal voltage, the crest voltage  $\times 0,707$  should be used for type selection.
5. A current impulse of 8/20  $\mu\text{s}$  (defined in IEC 60-2 section 6) is used as a standard for impulse current and clamping voltage ratings. The transient energy is given for one impulse applied during the life of the component. Figure 3 gives the derating for different numbers and longer duration of impulses. The shift of the varistor voltage does not exceed  $\pm 5\%$ .
6. High energy surges are generally of longer duration. The max. energy for 1 minute 10/1000  $\mu\text{s}$  is given as a reference for long duration impulses. This impulse can be characterized by peak current  $I_p$  and impulse width  $t_2$  (virtual time to half  $I_p$  value, defined in IEC 60-2 section 6), see Fig. 5. If  $V_p$  is the clamping voltage corresponding to  $I_p$ , the energy absorbed in the VDR is determined by equation  $E = K \cdot V_p \cdot I_p \cdot t_2$ ; K depends on  $t_2$ . When  $t_1$  is 8 to 10  $\mu\text{s}$  and  $t_2 = 20 \mu\text{s}$ ,  $K = 1$ ; when  $t_2 = 50 \mu\text{s}$ ,  $K = 1,2$ ; when  $t_2 = 100 \mu\text{s}$ ,  $K = 1,3$ ; when  $t_2 = 1000 \mu\text{s}$ ,  $K = 1,4$ .

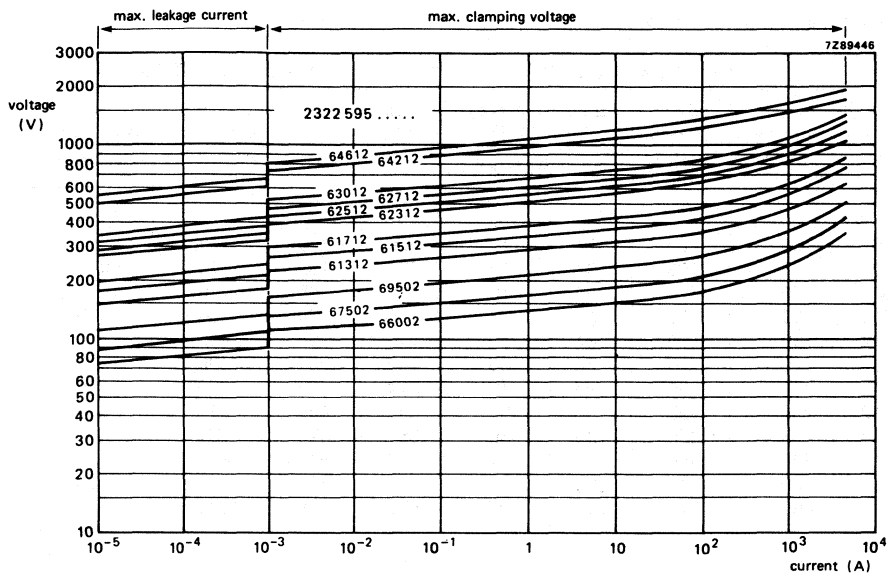

Fig. 2 V/I characteristics.

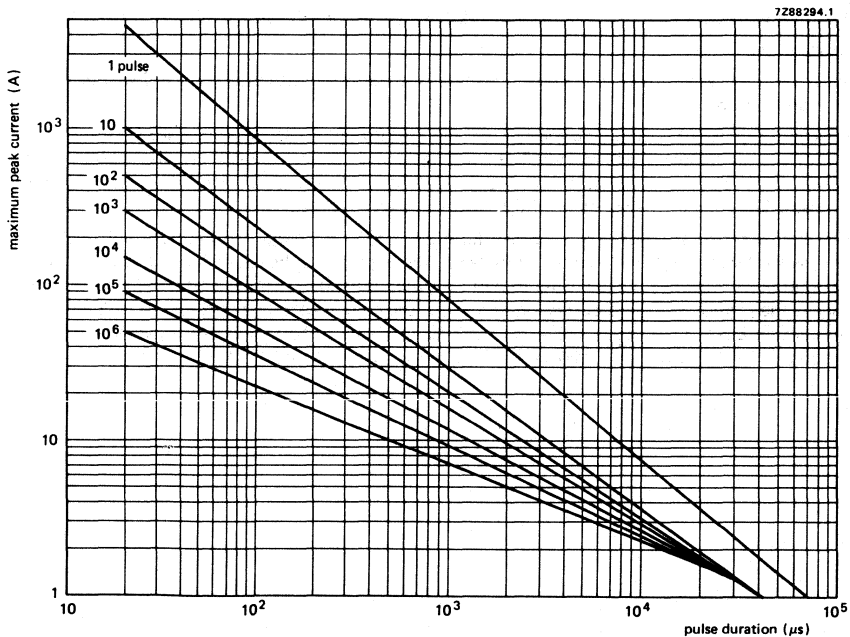

Fig. 3 Max. applicable transient current as a function of pulse duration.

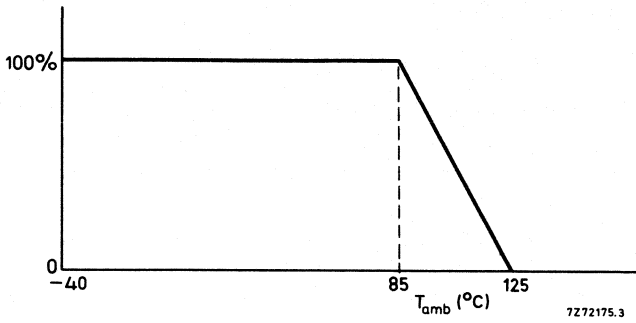

Fig. 4 Derating of max. d.c. and r.m.s. working voltage with temperature.

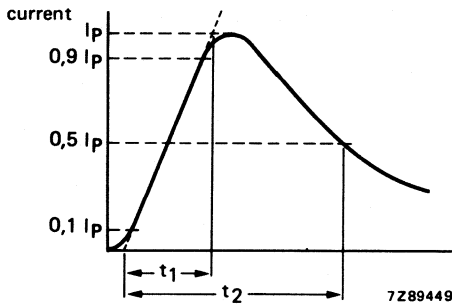

Fig. 5.

**PACKAGING**

The resistors 2322 595 6.... are supplied in bulk packing only in boxes of 250.



## LIGHT DEPENDENT RESISTORS (LDR)



	page
<b>General</b>	<b>68</b>
<b>Survey</b>	<b>69</b>
<b>Data sheets</b>	<b>70</b>

## GENERAL

Light dependent resistors (LDRs) are made from cadmium sulphide containing no or very few free electrons when not illuminated. Its resistance is then quite high. When it absorbs light, electrons are liberated and the conductivity of the material increases. Cadmium sulphide is therefore a photo-conductor. The approximate relationship between the resistance and illumination is:

$$R = A \cdot L^{-\alpha}$$

where: R = resistance in  $\Omega$   
L = illumination in lux  
A and  $\alpha$  are constants.

The value of  $\alpha$  depends on the cadmium sulphide used and on the manufacturing process. Values around 0,7 to 0,9 are quite common. The relationship between the resistance and the illumination is shown in the graph on the next page.

### SPECTRAL RESPONSE

The resistors are only light dependent over a limited range of wavelengths. LDRs have their maximum response at about 680 nm.

### TEMPERATURE DEPENDENCY

Electrons can be excited not only by photons but also by thermal agitation. The dark resistance is therefore not infinite at normal temperatures. It increases with the ambient temperature and can be decreased by cooling the device.

The temperature can also affect the resistance under illumination. At practical illumination levels and normal ambient temperatures the temperature coefficient is, however, very small and can be neglected.

### RECOVERY RATE

When an LDR is brought from a certain illumination level into total darkness, the resistance does not increase immediately to the dark value. The recovery rate is specified in  $k\Omega/s$  and for current LDR types it is more than 200  $k\Omega/s$  (during the first 20 seconds starting at a light level of 1,000 lux).

The recovery rate is much greater in the reverse direction, e.g. going from darkness to an illumination level of 300 lux, it takes less than 10 ms to reach a resistance which corresponds with a light level of 400 lux.

## SURVEY

minimum dark resistance	light resistance	maximum dissipation at 40 °C	ambient temperature range	catalogue number
10 MΩ	75 to 300 Ω	0,1 W	-30 to +60 °C	2322 600 93001
1 MΩ	max. 110 Ω			2322 600 93002
10 MΩ	75 to 300 Ω			2322 600 94001
10 MΩ	75 to 300 Ω	0,2 W	-20 to +60 °C	2322 600 95001
10 MΩ	max. 250 Ω			2322 600 95003
1 MΩ	max. 110 Ω			2322 600 95006
10 MΩ	30 to 96 Ω			2322 600 95008
10 MΩ	150 to 300 Ω			2322 600 95009
Recovery rate			min. 200 kΩ/s	

## DESCRIPTION

Disc shaped resistors made of cadmium sulphide. They are sealed and have two solid tinned copper wires.

## APPLICATION

LDRs are intended for non-critical on/off applications, in which a lamp or a relay is operated either directly (low power) or via a suitable amplifier (high power) e.g. in toys.

## TYPICAL CHARACTERISTICS

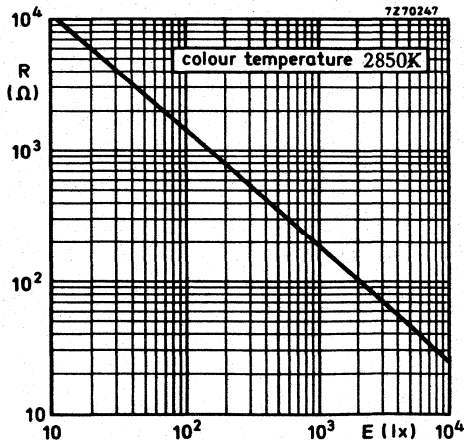

Resistance as a function of illumination.

## LIGHT DEPENDENT RESISTORS

### QUICK REFERENCE DATA

Dark resistance $R_D$	2322 600 93001	$> 10 \text{ M}\Omega$
	2322 600 93002	$> 1 \text{ M}\Omega$
Light resistance $R_L$	2322 600 93001	75 to 300 $\Omega$
	2322 600 93002	$< 110 \text{ }\Omega$
Recovery rate		$> 200 \text{ k}\Omega/\text{s}$
Maximum dissipation at 40 °C		0,1 W
Ambient temperature range		-30 to +60 °C

### MECHANICAL DATA

Outline drawing

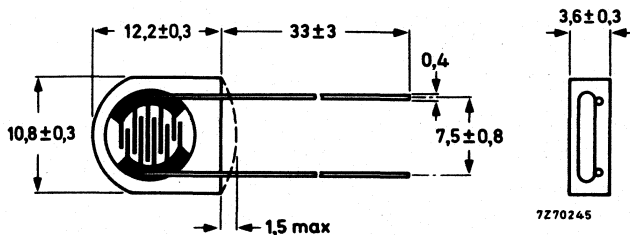

#### Marking

None

#### Mass

0,75 g approximately

#### Mounting

In any position by soldering the leads at least 10 mm from the body.

#### Robustness of terminations

Tensile strength

5 N

Bending

2,5 N

#### Soldering

Solderability

max. 240 °C, max. 4 s

Resistance to heat

max. 265 °C, max. 11 s



**ELECTRICAL DATA**

Dark resistance $R_D$	2322 600 93001 2322 600 93002	min. 10 M $\Omega$ min. 1 M $\Omega$
Light resistance $R_L$	2322 600 93001 2322 600 93002	75 to 300 $\Omega$ max. 110 $\Omega$
Recovery rate		min. 200 k $\Omega$ /s
Dissipation at 40 °C		max. 0,1 W
Capacitance at 1000 Hz		max. 8 pF
Repetitive peak voltage not exceeding max. dissipation		max. 150 V
Dielectric withstanding peak voltage between terminals and body		min. 200 V
Dielectric d.c. test voltage between terminals for 1 s in total darkness		200 V
Operating ambient temperature range		-30 to + 60 °C

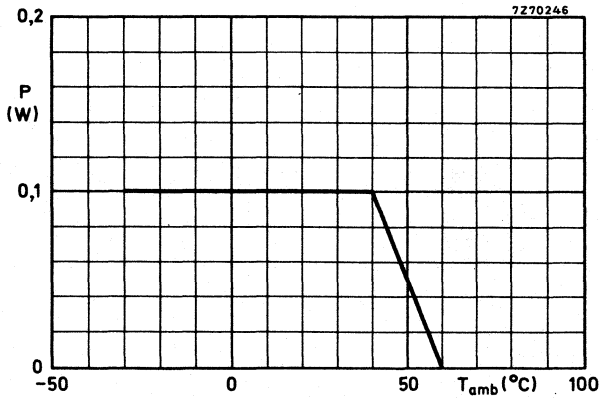

Permissible dissipation as a function of ambient temperature.

**PACKAGING**

250 per box

## LIGHT DEPENDENT RESISTOR

### QUICK REFERENCE DATA

Dark resistance $R_D$	$> 10 \text{ M}\Omega$
Light resistance $R_L$	75 to $300 \Omega$
Recovery rate	$> 200 \text{ k}\Omega/\text{s}$
Maximum dissipation at $40 \text{ }^\circ\text{C}$	0,1 W
Ambient temperature range	$-30 \text{ to } +60 \text{ }^\circ\text{C}$

### MECHANICAL DATA

Outline drawing

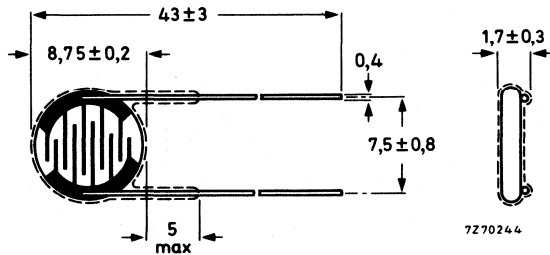

#### Marking

None

#### Mass

0,35 g approximately

#### Mounting

In any position by soldering the leads at least 10 mm from the body.

#### Robustness of terminations

Tensile strength

5 N

Bending

2,5 N

#### Soldering

Solderability

max.  $240 \text{ }^\circ\text{C}$ , max. 4 s

Resistance to heat

max.  $265 \text{ }^\circ\text{C}$ , max. 11 s

**ELECTRICAL DATA**

Dark resistance $R_D$	min. 10 M $\Omega$
Light resistance $R_L$	75 to 300 $\Omega$
Recovery rate	min. 200 k $\Omega$ /s
Dissipation at 40 °C	max. 0,1 W
Capacitance at 1000 Hz	max. 8 pF
Repetitive peak voltage, not exceeding max. dissipation	max. 150 V
Dielectric withstanding peak voltage between terminals and body	200 V
Dielectric d.c. test voltage between terminals for 1 s in total darkness	200 V
Operating ambient temperature range	-30 to +60 °C

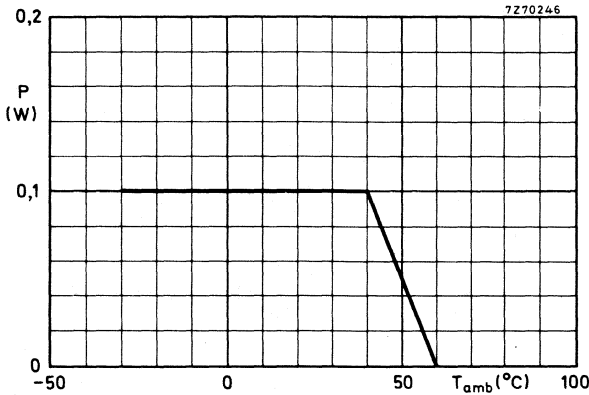

Permissible dissipation as a function of ambient temperature.

**PACKAGING**

250 per box



## LIGHT DEPENDENT RESISTORS

### QUICK REFERENCE DATA

Dark resistance $R_D$	$> 10 \text{ M}\Omega$ 2322 600 95006 $> 1 \text{ M}\Omega$
Light resistance $R_L$	30 to 300 $\Omega$
Recovery rate	$> 200 \text{ k}\Omega/\text{s}$
Maximum dissipation at 40 °C	0,2 W
Ambient temperature range	-20 to + 60 °C

### MECHANICAL DATA

Outline drawing

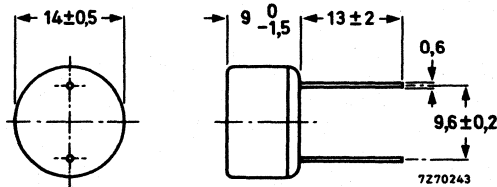

#### Marking

Year and month of production is printed on the body in yellow.

#### Mass

1,3 g approximately.

#### Mounting

in any position by soldering the leads at least 10 mm from the body.

#### Robustness of terminations

Tensile strength

10 N

Bensing

5 N

#### Soldering

Solderability

max. 240 °C, max. 4 s

Resistance to heat

max. 265 °C, max. 11 s

## ELECTRICAL DATA

catalogue number	resistance	
	dark value $R_D$	light value $R_L$
2322 600 95001	min. 10 M $\Omega$	75 to 300 $\Omega$
95003	min. 10 M $\Omega$	max. 250 $\Omega$
95006	min. 1 M $\Omega$	max. 110 $\Omega$
95008	min. 10 M $\Omega$	30 to 96 $\Omega$
95009	min. 10 M $\Omega$	150 to 300 $\Omega$

Recovery rate	min. 200 k $\Omega$ /s
Dissipation at 40 °C	max. 0,2 W
Capacitance at 1000 Hz	max. 6 pF
Repetitive peak voltage not exceeding max. dissipation	max. 110 V
Dielectric withstanding peak voltage between terminals and case	150 V
Dielectric d.c. test voltage between terminals for 1 s in total darkness	150 V
Operating ambient temperature range	-20 to +60 °C

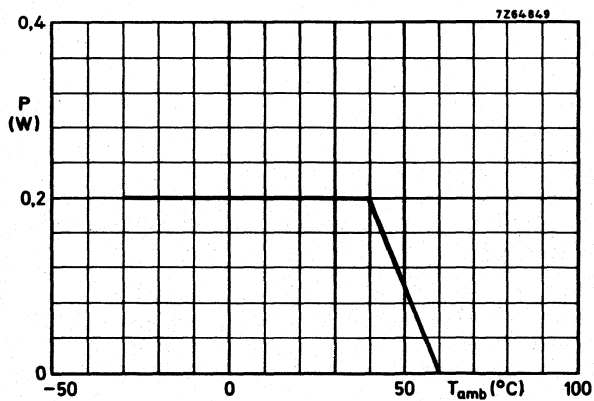

Permissible dissipation as a function of ambient temperature.

## PACKAGING

125 per box



## NEGATIVE TEMPERATURE COEFFICIENT THERMISTORS (NTC)





	page
Survey	78
Introduction	82
How to measure NTC thermistors	90
Choice of type	91
Applications	93
Data sheets	103



# NTC THERMISTORS

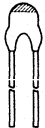
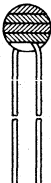

## SURVEY

type	P <sub>max</sub> W	temp. range at zero power °C	B <sub>25/85</sub> -value ±5% K	R <sub>25</sub> Ω	catalogue number
DISC 	1	-25 to +125	2600 to 5450	1,1 to 1300	2322 610 1....
 		25 to +100 -25 to +155	2975	930 to 2200 5	2322 611 2322 644 90012
	0,25  0,25	-25 to +125  -55 to +85	3660 to 4150  4000	2,7 k to 330 k R <sub>-30</sub> = 50000 R <sub>-10</sub> = 15000 R <sub>-10</sub> = 15000 R <sub>+25</sub> = 2700	2322 640 1.... 2322 640 90012 2322 640 90014
	0,5	-25 to +125	2675 to 4650	3,3 to 470 k.	2322 642 6....
	1,5	-25 to +125	3500 to 4300	150 to 4700	2322 644 1....
		-25 to +155	4650 3350	82 min. 15	2322 644 90004 90005

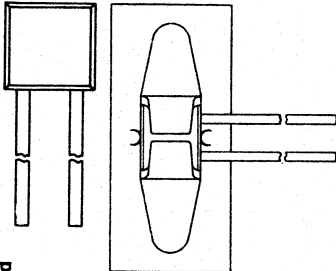
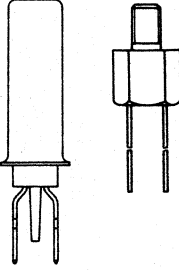
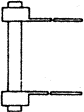

 <p>moulded</p>	0,25	-55 to +85	4000	$R_{-30} = 50000$ $R_{-10} = 15000$	2322 640 90013 98013
	0,25	-55 to +85	4000	$R_{-10} = 15000$ $R_{-25} = 2700$	2322 640 90015 98015
	0,25	-10 to +125	3750	$R_{+25} = 12000$ $R_{+100} = 950$	2322 640 90004 98004
	0,25	-25 to +200	4300	$R_{+100} = 16700$ $R_{+200} = 1120$	2322 640 90005 98005
 <p>in special housing</p>	0,25	-25 to +110	3700 3720	$R_{+25} = 12\text{ k}$ $R_{+90} = 1300$	2322 640 90007 90021
	0,5	-25 to +100	2675 to 4650	3,3 to 470 k	2322 642 7 ...
 <p>ROD</p>	0,6 1,5 2,3	-25 to 155	3300 to 4300 3250 to 4150 3200 to 4200	$4,7\text{ k to }470\text{ k}$ $4,7\text{ k to }150\text{ k}$ $4,7\text{ k to }150\text{ k}$	2322 635 0 ... 2322 636 0 ... 2322 637 0 ...

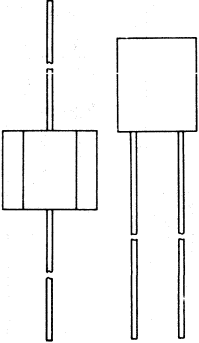
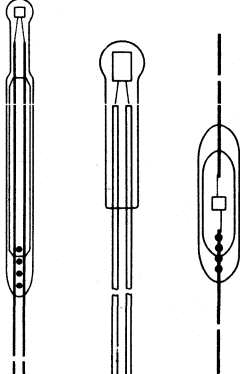

# NTC THERMISTORS

type	P <sub>max</sub> W	temp. range at zero power °C	B <sub>25/85</sub> value ± 5% K	R <sub>25</sub> Ω	catalogue number
<b>MINIATURE BEAD</b> 		-55 to +200	2075 to 4100	1k to 1M	2322 633 0....
		-55 to +200	2075 to 4100	1k to 1M	2322 633 1....
<b>glass encapsulated</b> 	0,1	-25 to +200/300	2075 to 4100	1k to 1M	2322 626 1....
	0,1	-25 to +200/300	2075 to 4100	1k to 1M	2322 626 2....
	0,06	-55 to +200	2075 to 4100	1k to 1M	2322 633 2....

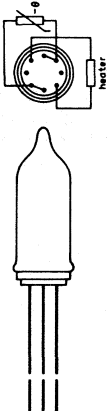
<p>INDIRECTLY HEATED</p> 	<p>0,015</p>	<p>-25 to + 85</p>	<p>3860</p>	<p>55</p>	<p>2322 628 90016</p>
--	--------------	--------------------	-------------	-----------	-----------------------



## INTRODUCTION

NTC thermistors are resistors with a high negative temperature coefficient of resistance. They are manufactured from oxides of the iron group of transition elements e.g. Cr, Mn, Fe, Co or Ni. These oxides have a high resistivity in the pure state, but can be transformed into semiconductors by adding small amounts of foreign ions which have a different valency.

Examples are:

- a. iron oxide  $\text{Fe}_2\text{O}_3$ , where a small part of the  $\text{Fe}^{3+}$ -ions are replaced by  $\text{Ti}^{4+}$ -ions. These  $\text{Ti}^{4+}$ -ions are compensated by an equal amount of  $\text{Fe}^{2+}$ -ions in order to maintain electroneutrality. At low temperatures the extra electrons of the  $\text{Fe}^{2+}$ -ions are situated on Fe-ions next to the  $\text{Ti}^{4+}$ -ions, but at higher temperatures they are gradually loosened from these sites and contribute to the conductivity. In this case we have obtained an electron- or n-type semiconductor.
- b. Nickel oxide  $\text{NiO}$ , or cobalt oxide  $\text{CoO}$ , with a partial substitution of  $\text{Li}^{1+}$ -ions for the  $\text{Ni}^{2+}$ - or  $\text{Co}^{2+}$ -ions. In this case the  $\text{Li}^{1+}$ -ions are compensated by an equal amount of  $\text{Ni}^{3+}$ - or  $\text{Co}^{3+}$ -ions. At low temperatures the so-called electron-holes (missing electrons) of the trivalent ions are near the foreign ions and again free to move through the crystals at higher temperatures. In this case a positively charged particle is the mobile charge carrier and therefore these materials are called p-type semiconductors.

Stabilizing oxides are sometimes added to achieve improved reproducibility and stability of the characteristics. Which of these compositions is used depends entirely on the required temperature coefficient and the specific resistance.

In examples a. and b. the conductivity  $\sigma$  of the materials can be generally described by

$$\sigma = n e \mu$$

where  $e$  represents the unit of electric charge and  $n$  and  $\mu$  the concentration and the mobility of the charge carriers respectively.

Both  $n$  and  $\mu$  depend on temperature. For  $n$  this dependence is exponential according to a Boltzmann law.

$$n \propto e^{-q_1/kT}$$

where  $q_1$  is related to the electrostatic binding energy of the carriers to the foreign ions. It is uncertain whether the temperature dependence of the mobility is comparable to that of charge carriers in germanium-type semiconductors ( $\mu \propto T^h$ ) or to that of ionic conductors where the ions need a thermal activation energy  $q_2$  for each jump to a neighbour site (hopping process). In the latter case the temperature dependence is described by:

$$\mu \propto \frac{e^{-q_2/kT}}{T} \quad (\propto = \text{direct proportional to})$$

The total temperature dependence of the conductivity is generally proportional to:

$$\sigma \propto T^{-c} \cdot e^{-(q_1 + q_2)/kT}$$

where  $q_2$  may be zero. In practice the exponential factor is the most important one, so that the resistance variation of these thermistors over a wide temperature range can be represented by:

$$R = A e^{B/T}$$

where  $R$  = resistance at absolute temperature  $T$ ,  
 $A$  and  $B$  are constants for a given resistor and  
 $e$  = the base of the natural logarithm ( $e = 2,718$ ).

Resistance is plotted as a function of temperature in Fig. 1, for three types with different values of  $A$  and  $B$ .

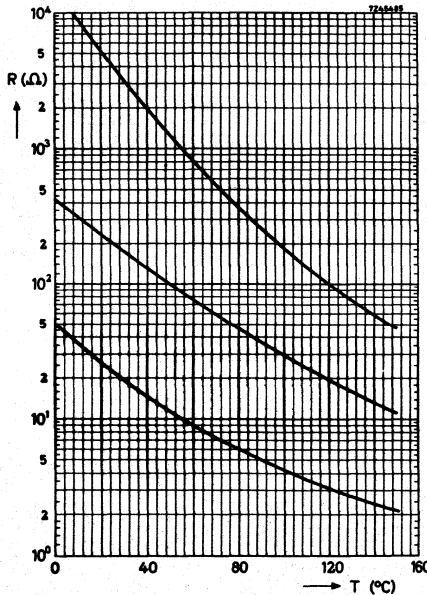

Fig. 1.

## MANUFACTURE

The manufacturing process is comparable to that of ceramics. After intensive mixing and addition of a plastic binder, the mass is shaped into the required forms, e.g. by extrusion (rods) or pressing (discs) and fired at a temperature high enough to sinter the constituent oxide. Electrical contacts are then added by burning in with silver paste or by other methods such as electroplating or metal spraying.

Miniature NTC thermistors are made by placing a bead of oxide paste between two parallel platinum alloy wires and then drying and sintering. The platinum alloy wires are 60  $\mu\text{m}$  diameter and 0,25 mm apart. During sintering the bead shrinks onto the wires to make a solid and reliable contact. Miniature NTC thermistors are usually mounted in glass to protect them against aggressive gases and fluids.

# NTC THERMISTORS

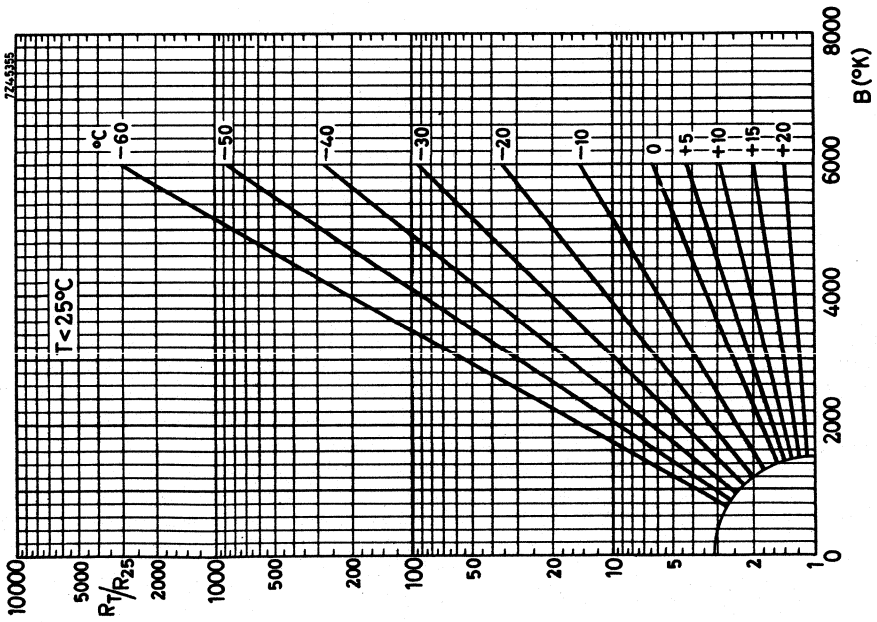
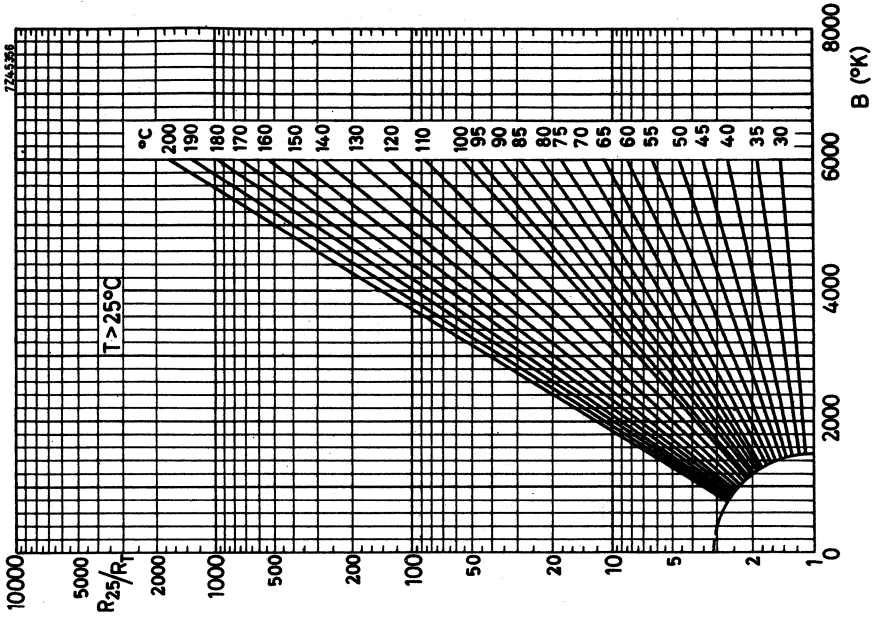

Fig. 2  $R_T/R_{25}$  as a function of B-value with temperature as a parameter. Fig. 3  $R_{25}/R_T$  as a function of B-value with temperature as a parameter.

For a particular NTC thermistor the value of B may be found as follows. The resistance value is measured at two temperatures,  $T_1$  and  $T_2$ :

$$R_1 = Ae^{B/T_1} \text{ and } R_2 = Ae^{B/T_2}.$$

Dividing yields:

$$\frac{R_1}{R_2} = e^{(B/T_1 - B/T_2)},$$

or:

$$\log R_1 - \log R_2 = B (1/T_1 - 1/T_2) \log e,$$

solving for B gives:

$$B = \frac{\ln R_1/R_2}{1/T_1 - 1/T_2} \quad (2)$$

In practice B varies slightly with increasing temperature.

From Eq. (1) the temperature coefficient of an NTC may be derived:

$$\alpha = \frac{1}{R} \cdot \frac{dR}{dT} = -\frac{B}{T^2}. \quad (3)$$

For the different materials the constant B may vary between 2000 and 5500 K:

e.g. a value of 3600 yields  $\alpha = -4\%$  per K at a temperature of 300 K. For calculating the resistance of an NTC at a particular temperature, when  $R_{25}$  and B are given in the data, the graphs of Figs 2 and 3 may be used, where for different B-values  $R_{25}/R_T$  and  $R_T/R_{25}$  are plotted against the B-value with the temperature of the NTC thermistor as parameter.



# NTC THERMISTORS

## V/I CHARACTERISTICS

Fig. 4 shows the relationship between current and voltage drop over the NTC thermistor when the latter is heated by this current to a temperature much higher than the ambient temperature. This characteristic was measured at a constant ambient temperature after equilibrium had been reached. For very small currents, the power consumption is too small to register a distinct rise in temperature or a decrease in resistance. In that part of the characteristic the relationship between voltage and current is therefore linear.

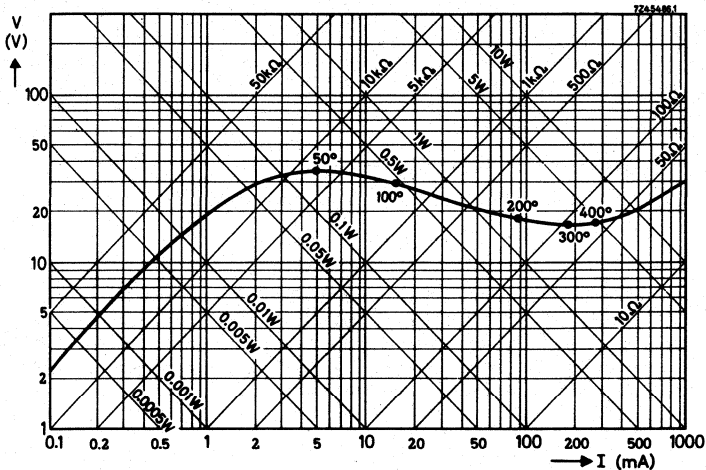

Fig. 4 Voltage versus current characteristics of an NTC thermistor.

Assuming:

- (a) a constant temperature throughout the body of the thermistor;
- (b) the heat transfer to be proportional to the difference in temperature between thermistor and surrounding medium (which is true for low temperatures);
- (c) the resistance to be defined by eq. (1)

$$R = \frac{V}{I} = A e^{B/T};$$

or:

$$\log_e R = \log_e A + B/T. \tag{4}$$

In case of equilibrium

$$W = VI = \delta (T - T_0), \tag{5}$$

in which  $T_0$  is the ambient temperature and  $\delta$  the dissipation factor (definition on next page).



From eqs (5) and (4) follows:

$$\log_e V + \log_e I = \log_e \delta + \log_e (T - T_0), \quad (6)$$

$$\log_e V - \log_e I = \log_e A + B/T. \quad (7)$$

Combination of these two yields:

$$\log_e V = \frac{1}{2} \log_e A \delta + \frac{1}{2} \log_e (T - T_0) + B/2T. \quad (8)$$

This form has an extreme as a function of T if:

$$\frac{d \log_e V}{dT} = 0. \quad (9)$$

In that case

$$\frac{1}{2(T - T_0)} - \frac{B}{2T^2} = 0 \quad (10)$$

which is true only for those values of T which satisfy:

$$T^2 - BT + BT_0 = 0, \quad (11)$$

$$T_{\max} = \frac{1}{2}B \pm \sqrt{\frac{1}{4}B^2 - BT_0}. \quad (12)$$

(The value with the minus sign gives the temperature corresponding to the maximum value of the voltage.) Only if  $B > 4T_0$  will this maximum be present. For the practical values of B (2000 – 4000 K) the temperature  $T_{\max}$  lies between 85 °C and 45 °C.

From these considerations, which are valid for static conditions only, it follows that the temperature corresponding to the maximum voltage only depends on the B-value of the material and not the actual resistance value.

## THERMAL TIME CONSTANT

The thermal time constant ( $\tau$ ) is defined as the ratio of the heat capacity (H) of the thermistor to its dissipation factor ( $\delta$ ).

The heat capacity (H) is the electrical energy the thermistor needs to raise 1 K in temperature (unit J/K).

The dissipation factor ( $\delta$ ) is the ratio at a specified ambient temperature of a change in power dissipation in a thermistor to the resultant body temperature change (unit mW/K).

The thermal time constant is the time required for the temperature of a thermistor to change by 63.2% of the difference between its initial and final body temperatures (according to IEC 539; 85 °C and 25 °C respectively), when subjected to a step function temperature change.

H is entirely dependent on the component design. The thermal time constant depends on  $\delta$  which varies for different media.

The thermal time constants mentioned in the data sheets are measured as follows, the method used depending on the application:

- by cooling in air under zero power conditions ( $\tau_c$ ).
- by warming or cooling, transferring the thermistor from ambient temperature of + 25 °C to a bath with a fluid of a higher or lower temperature under zero power conditions ( $\tau_r$ , termed "response time" in the data sheets).
- by internal heating, subjecting the thermistor to a constant voltage or current ( $\tau_v$  or  $\tau_i$ ).

# NTC THERMISTORS

If the thermistor has a uniform temperature during cooling, the following equation is valid for the cooling of an NTC in the time interval dt:

$$-HdT = \delta (T - T_0) dt \quad (13)$$

in which  $T_0$  is the ambient temperature.

Eq. (13) yields:  $(T - T_0) = (T_1 - T_0) e^{-t/\tau_c}$  (14)

In a corresponding way the following equation can be derived for warming up:

$$(T - T_0) = (T_1 - T_0) (1 - e^{-t/\tau_r})$$

The third case is more complicated and is based on the equation:

$$P dt = H dT + \delta (T_1 - T_0) dt$$

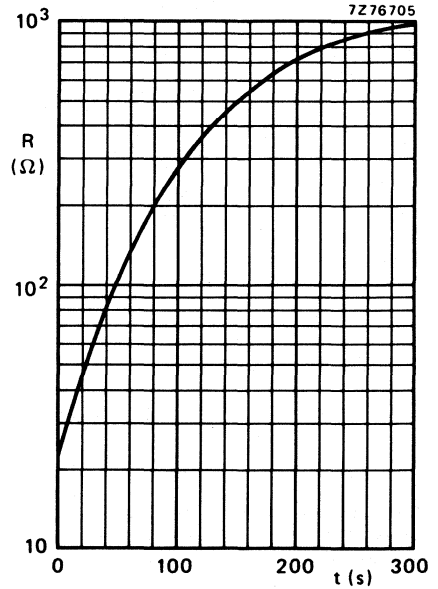

Fig. 5 Variation of resistance with time under normal cooling conditions of a rod type NTC. Ambient temperature 25 °C.

## SPREAD

### Resistance specified at + 25 °C ( $R_{25}$ )

The  $R_{25}$  and the B-value are specified with a certain spread. The tolerance on the resistance at 25 °C is normally specified as  $\pm 5\%$  or  $\pm 10\%$ .

The B-value usually has a tolerance of  $\pm 5\%$ . Due to the spread in B-value, the deviation from the nominal curve at temperatures other than 25 °C can be greater than the specified tolerance at 25 °C (Fig. 6).

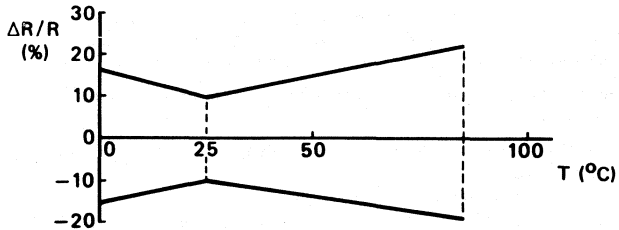

Fig. 6.

## Temperature tolerances

For temperature sensors, it is appropriate to express the measuring error as a temperature tolerance rather than as  $\Delta R/R$ .

For one-point sensors, the temperature tolerances corresponding with the spread in  $R_{ref}$  and B-value ( $T_{ref}$  = reference temperature; usually 25 °C) can be calculated from:

$$R_T = R_{ref} \cdot e^{B \left( \frac{1}{T} - \frac{1}{T_{ref}} \right)},$$

in which T and  $T_{ref}$  are in K.

The result of the calculation yields

at  $T \approx T_{ref}$ :

$$\pm \Delta T_{ref} = \frac{\Delta R_{ref}}{R_{ref}} \cdot \frac{1}{B/T^2}$$

at  $T < T_{ref}$ :

$$\pm \Delta T = \frac{\frac{\Delta R_{ref}}{R_{ref}} + \frac{\Delta B}{B} B \left( \frac{1}{T} - \frac{1}{T_{ref}} \right)}{B/T^2}$$

at  $T > T_{ref}$ :

$$\pm \Delta T = \frac{\frac{\Delta R_{ref}}{R_{ref}} + \frac{\Delta B}{B} B \left( \frac{1}{T_{ref}} - \frac{1}{T} \right)}{B/T^2}$$

For a practical case, the maximum error in K as a function of the temperature to be measured is expressed in Fig. 7.

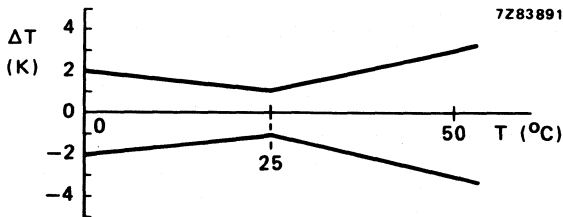

Fig. 7.

# NTC THERMISTORS

## Resistance specified at more than one temperature (2 or 3-point sensors)

Thermistors which are specified at 2 or 3 points of their R/T characteristic are more accurate. They have a closer tolerance and the spread in B-value has less influence because it is included in the tolerance at the specified points.

The tolerances in the reference points can be expressed either as a temperature deviation for the reference resistance or as a resistance tolerance at the reference temperature. This has no influence on the resulting measuring error which is minimum in the temperature region between the reference points, as illustrated in Fig. 8.

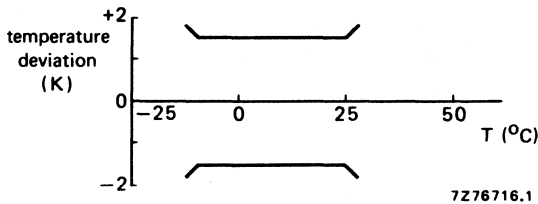

Fig. 8.

From Figs 7 and 8 it is obvious that 2 or 3-point sensors are particularly suited for applications with the following characteristics:

- temperature measurement over a certain temperature range
- high accuracy
- no further calibration for sensor tolerances in the electrical circuitry.

## HOW TO MEASURE NTC THERMISTOR RESISTANCE

The published  $R_T$  values are measured at the temperature T.

The published B-value at 25 °C is the result of a measurement at 25 °C and one at 85 °C. So, please, use these two temperatures for checking.

The following general precautions have to be taken when measuring NTC thermistors:

- Never measure thermistors in air as this is quite inaccurate and gives deviations of 1 or 2 K. For measurement at room temperature or below, use petrol or some other non-conductive and non-aggressive fluid. For higher temperatures use oil, preferably silicon oil.
- Use a thermostat with an accuracy of at least 0,1 °C. Even if the liquid is well stirred, there is still a temperature gradient in the fluid. So measure the temperature as close to the NTC as possible.
- After placing the NTC in the thermostat wait until temperature equilibrium between the NTC and the fluid is obtained. For some types this may take more than 1 minute.
- Keep the measuring voltage as low as possible otherwise the NTC will be heated by the measuring current. Miniature NTC thermistors are especially sensitive in this respect. Measuring voltages of less than 0,5 V are recommended.
- For high temperature measurements it is recommended that stem correction be applied to the thermometer reading.

## CHOICE OF TYPE

When selecting an NTC thermistor the following main characteristics should be considered:

- Resistance value(s) and temperature coefficient.
- Accuracy of resistance value(s).
- Power to be dissipated
  - (a) without perceptible change in resistance value due to self heating
  - (b) with maximum change in resistance value.
- Permissible temperature range.
- Thermal time constant, if applicable.
- Form best suited to the purpose:
  - basic forms are rod, disc and bead.
- Protection against undesired external influences, if necessary.

When it is impossible to find an NTC thermistor to fulfil all requirements, it is often more economical to adapt the values of other circuit components to the value of a series-manufactured NTC. Sometimes, a standard NTC can be used with simple parallel and series resistors where otherwise a special type would have been necessary.

If no suitable combination can be found, the development of a special type can be considered. In this case a specification of the requirements is necessary. A description of the circuit in which the NTC has to be used is most useful.

### DEVIATING CHARACTERISTICS

The following example explains the resistance values resulting from combinations of NTCs with normal resistors.

Suppose an NTC must have a resistance of  $50 \Omega$  at  $30^\circ\text{C}$  and  $10 \Omega$  at  $100^\circ\text{C}$ . A standard type having this characteristic is not included in our programme. The problem may, however, be solved by using a standard NTC and two fixed resistors. If an NTC disc with a cold resistance of  $130 \Omega$  is mounted in a series and parallel arrangement with two fixed resistors of  $6 \Omega$  and  $95 \Omega$  as illustrated in Fig. 9, the resistance of the combination at  $30^\circ\text{C}$  and at  $100^\circ\text{C}$  will meet the requirements. Figure 10 shows the new resistance versus temperature graph, together with that of the NTC thermistor. It should be remembered that the temperature coefficient of the combination will always be lower than that of the NTC thermistor alone. This is clearly illustrated by Fig. 11, where the change in the resistance/temperature graph is shown for different values of series and parallel resistors.

### REMARKS ON THE USE OF NTC THERMISTORS

Do not use unprotected thermistors in conducting fluids or aggressive and reducing gases which may cause a change in thermistor characteristics.

For temperature measurements do not use too high a voltage on the NTC thermistor as self-heating may cause incorrect readings. The dissipation constant indicates the maximum permissible measuring power.



# NTC THERMISTORS

## Choice of type

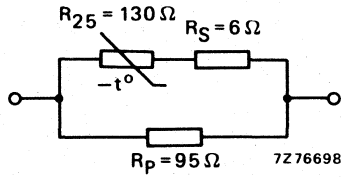

Fig. 9 NTC thermistor/resistor combination to change the R/T characteristic.

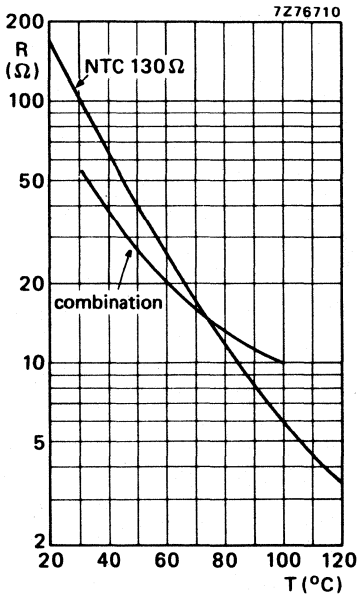

Fig. 10 Resistance as a function of temperature for the circuit of Fig. 7.

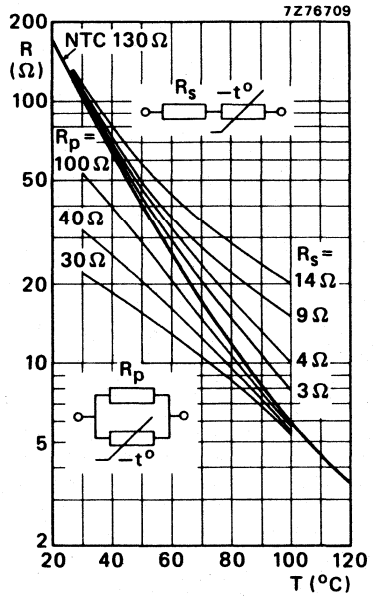

Fig. 11 Resistance as a function of temperature with the values of series and parallel resistors as parameters.

## APPLICATIONS

According to the essential properties of the NTC their applications may be classified into three main groups:

- (I) Applications in which advantage is taken of the dependence of the resistance on the temperature:

$$R = f(T).$$

This group is split into two subsections:

- (a) The temperature of the NTC thermistor is determined only by the temperature of the ambient medium (or by the current in a separate heater winding).  
(b) The temperature of the NTC thermistor is also determined by the dissipation in the NTC thermistor itself.

- (II) Applications in which the time dependence is decisive.  
In that case the temperature is considered as a parameter, and is written:

$$R = f(t).$$

This group comprises all applications which make use of the thermal inertia of NTC thermistors.

- (III) The third group of applications uses mainly the property of the temperature coefficient being highly negative:

$$\alpha < 0.$$

Also in this group applications are listed which take advantage of the fact that the absolute value of the temperature coefficient is so high, that a part of the  $V = f(I)$  curve shows a negative slope.



## APPLICATION EXAMPLES

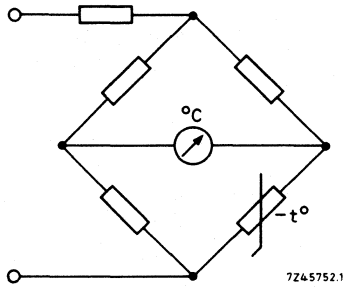

Fig. 12 Temperature measurement in industrial and medical thermometers.

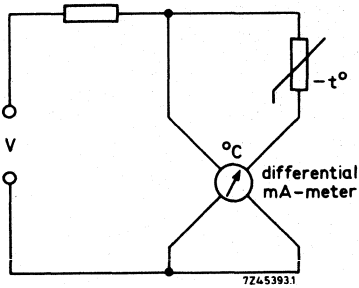
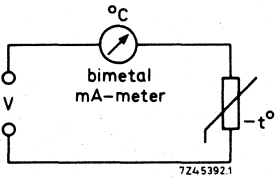

Fig. 13  
Temperature measurement in cars.  
Cooling water measurements with bimetal  
or differential milliammeters.

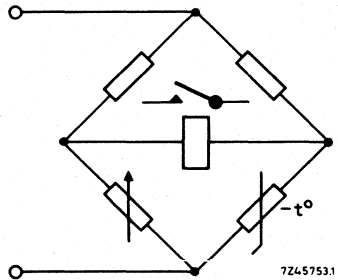

Fig. 14  
Temperature control with a bridge  
incorporating an NTC thermistor and a  
relay or a static switching device.



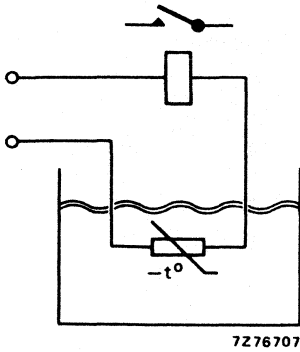

Fig. 15 Liquid level control.

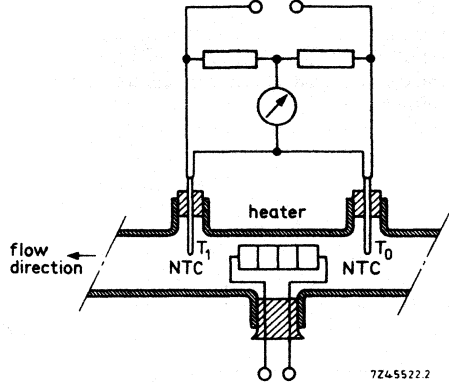

Fig. 16  
Flow measurement of liquids. The temperature difference between  $T_1$  and  $T_0$  is a measure for the velocity of the fluid.

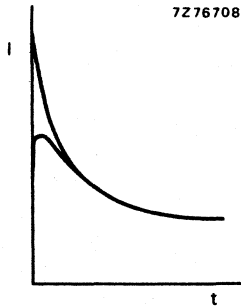
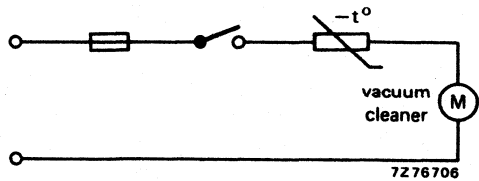
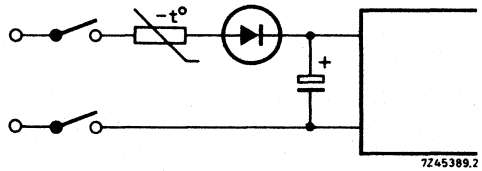
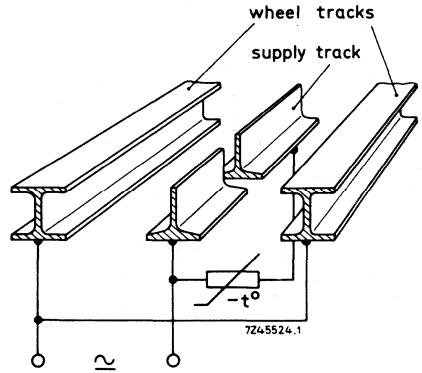
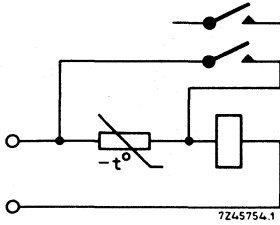

Fig. 17  
Inrush current limiter, e.g. for protection of Si-diodes, fuses and switches.



# NTC THERMISTORS

**Fig. 18**  
 Delaying action of relays. Due to the thermal inertia of the NTC, it takes some time before the relay is activated. If necessary the NTC can be short-circuited after the relay is activated thus leaving the NTC time for cooling.



**Fig. 19**  
 Model trains. As soon as the train comes on the isolated supply trip, it stops. The NTC heats up and gradually the train starts again.

**Fig. 20**  
 Gain compensation or gain control with an indirectly heated NTC.

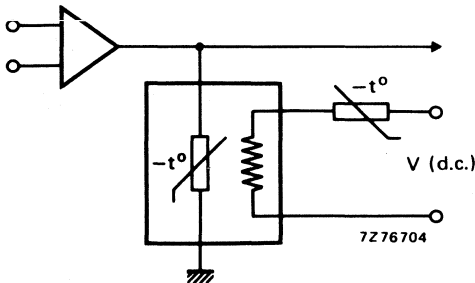
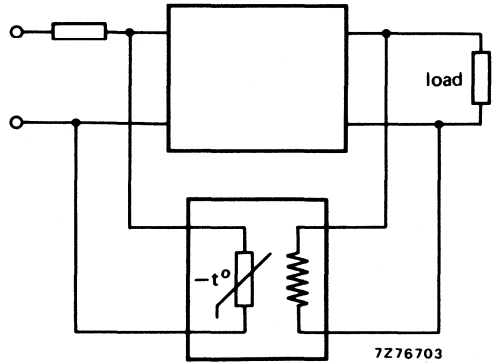

**Fig. 21**  
 Compensation for the influence of ambient temperature variations in an h.f. amplifier.

Fig. 22  
Temperature compensation in transistor circuits. Push-pull compensation.

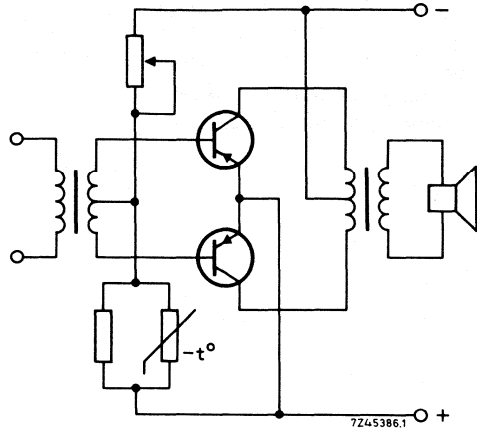

Fig. 23  
Transformerless audio output stage with temperature compensation.

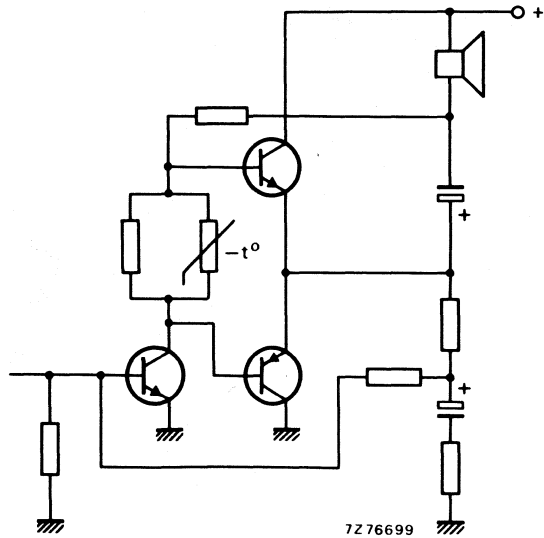

Fig. 24  
Stabilization with temperature of an  
a.g.c. amplifier in a television set.

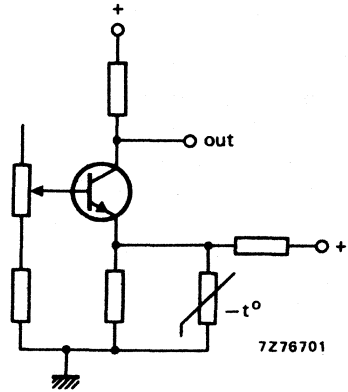

Fig. 25  
Compensation of drift in field deflection coils.  
The influence of the positive temperature  
coefficient of the copper windings is compensated  
by means of an NTC thermistor.

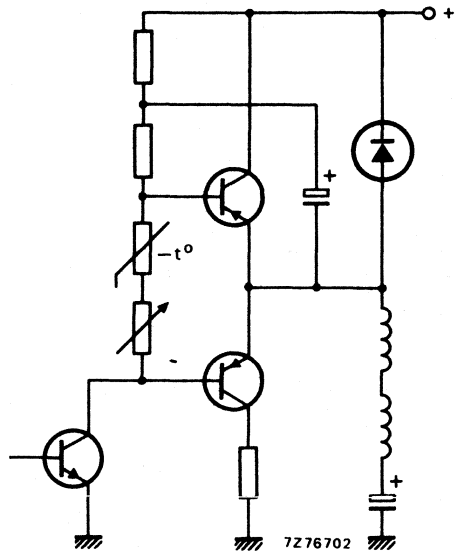

Fig. 26 Simple thermostat.

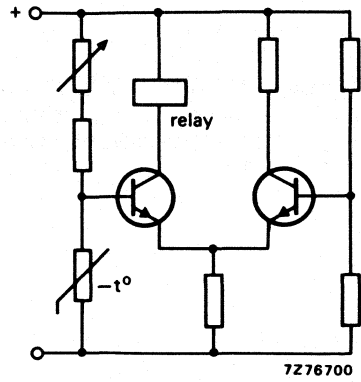
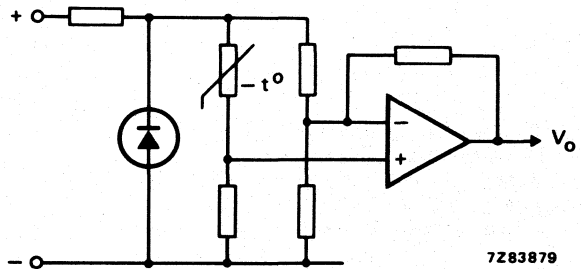

Fig. 27 Temperature sensing bridge with amplifier. The op-amp acts as difference amplifier. The sensitivity can be very high.



# NTC THERMISTORS

Fig. 28 Basic temperature sensing configuration. The operational amplifier, e.g. type NE532, acts as a Schmitt trigger. The transfer characteristic is given in Fig. 29.

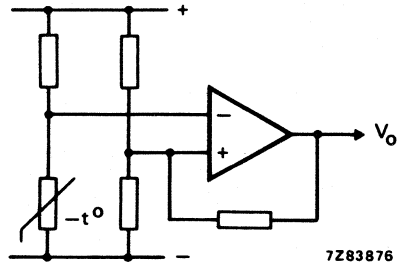

Fig. 29.

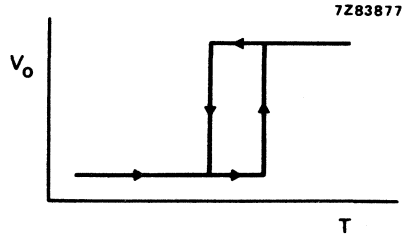

Fig. 30 Temperature controlled oscillator. This is a simple interface circuit for digital and microcomputer-controlled systems. The frequency of the output pulses is proportional to the temperature of the NTC thermistor. See Fig. 31.

$$f = \frac{1,49}{(R_{NTC} + 2R_B) C}$$

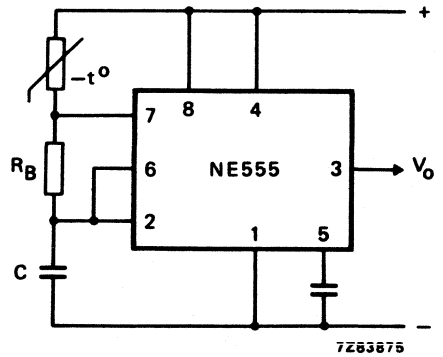
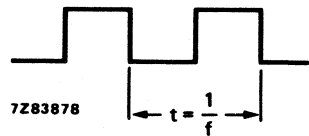

Fig. 31.



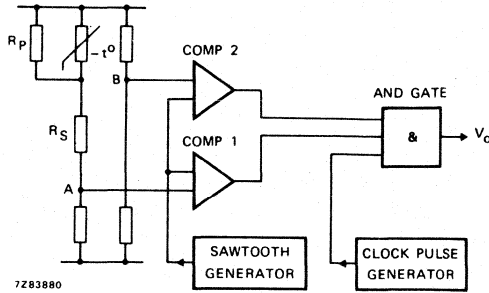

Fig. 32 Temperature sensing bridge with 0 °C offset and analogue to digital conversion. Due to  $R_p$  and  $R_s$  the voltage at point A varies linearly with the temperature of the NTC thermistor. The voltage at point B is equal to the voltage at point A when the temperature of the NTC thermistor is 0 °C. Both voltages are fed to the comparator circuit. See also Fig. 33.

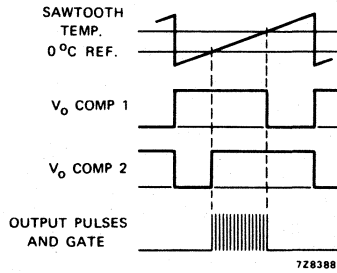

Fig. 33.

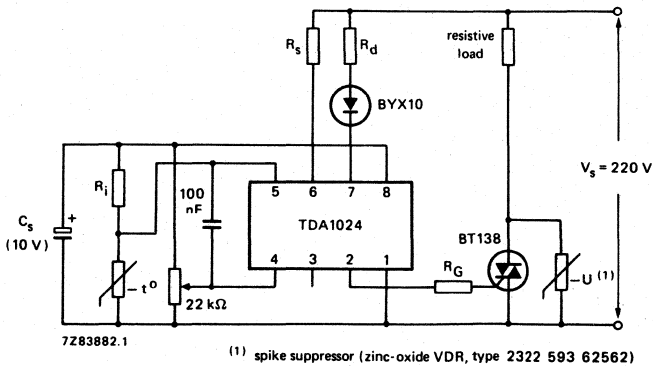

Fig. 34 Thermostat for room temperature control with a 2-point NTC thermistor as the sensing element. The TDA1024 triggers the triac during the zero crossings of the mains voltage only when the voltage across the NTC thermistor is higher than the voltage at the slider of the 22 kΩ potentiometer. (For complete information see our Technical Informations 010 and 025).





**NTC THERMISTORS**

disc

**QUICK REFERENCE DATA**

Resistance value at +25 °C	1,1 to 1300 Ω
B <sub>25/85</sub> -value	2600 to 5450 K
Maximum dissipation	1 W
Dissipation factor	10 mW/K
Thermal time constant	60 s approx.
Operating temperature range at zero power at maximum power	-25 to +125 °C 0 to +55 °C

**APPLICATION**

General purpose.

**DESCRIPTION**

Disc thermistor with negative temperature coefficient with two tinned copper wires. It is not lacquered, not insulated and has a colour code.

**MECHANICAL DATA**

Outlines

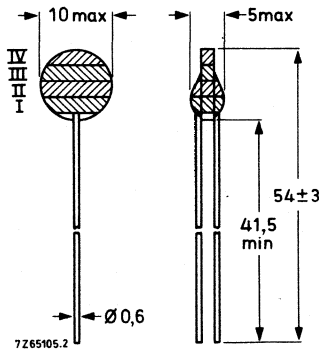

Fig. 1.



**Marking (see Fig. 1)**

The thermistors are marked with three colour bands showing their resistance value ( $R_{25}$ ) in code as indicated in the table. Thermistors with a tolerance on  $R_{25}$  of 10% have a fourth band in silver.

**Mass**

1,0 to 1,3 g

**Mounting**

In any position by soldering.

**Robustness of terminations**

Tensile strength 10 N

Bending 5 N

**Soldering**

Solderability max. 240 °C, max. 4 s

Resistance to heat max. 240 °C, max. 4 s

**PACKAGING**

250 thermistors in a cardboard box.

**ELECTRICAL DATA**

Maximum dissipation \* 1 W

Dissipation factor \* 10 mW/K approx.

Thermal time constant \* 60 s approx.

Heat capacity \* 0,6 J/K approx.

Operating temperature  
at zero power -25 to +125 °C

at maximum power 0 to +55 °C

See further Table 1.

\* Measurements made in still air, between two phosphor-bronze wires ( $\phi$  1,3 mm).

Table 1 Catalogue numbers 2322 610 1.....

suffix of catalogue number		R <sub>25</sub> Ω	B <sub>25/85</sub> ± 5% K	temperature coefficient %/K	colour code		
tol. ± 10%	tol. ± 20%				I	II	III
2118	1118	1,1	2600	-2,90	brown	brown	gold
2228	1228	2,2	2675	-3,00	red	red	gold
2408	1408	4	2800	-3,15	yellow	black	gold
2608	1608	6	2825	-3,15	blue	black	gold
2808	1808	8	2900	-3,25	grey	black	gold
2109	1109	10	2950	-3,30	brown	black	black
2129	1129	12	3050	-3,40	brown	red	black
2159	1159	15	3125	-3,50	brown	green	black
2339	1339	33	3250	-3,65	orange	orange	black
2509	1509	50	3300	-3,70	green	black	black
2829	1829	82	4400	-4,95	grey	red	black
2131	1131	130	4600	-5,15	brown	orange	brown
2501	1501	500	5200	-5,85	green	black	brown
2132	1132	1300	5450	-6,15	brown	orange	red



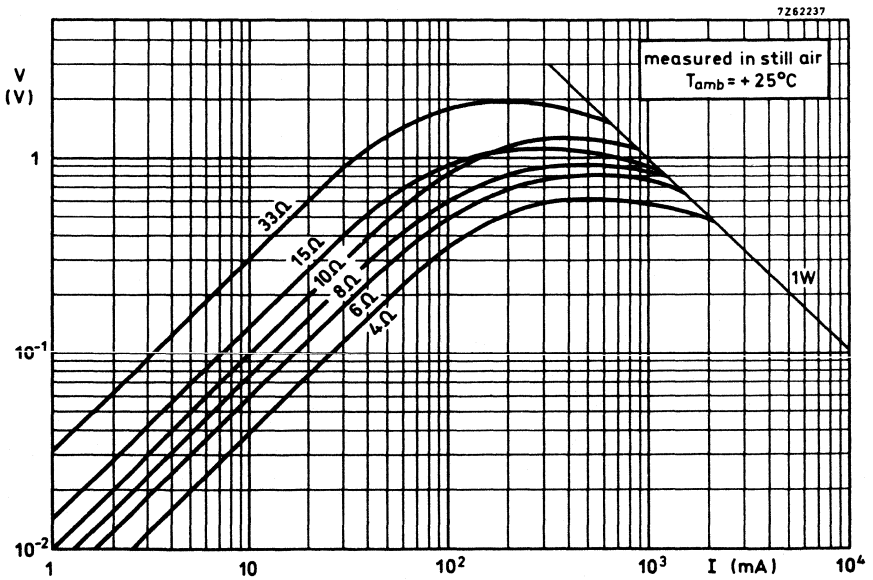
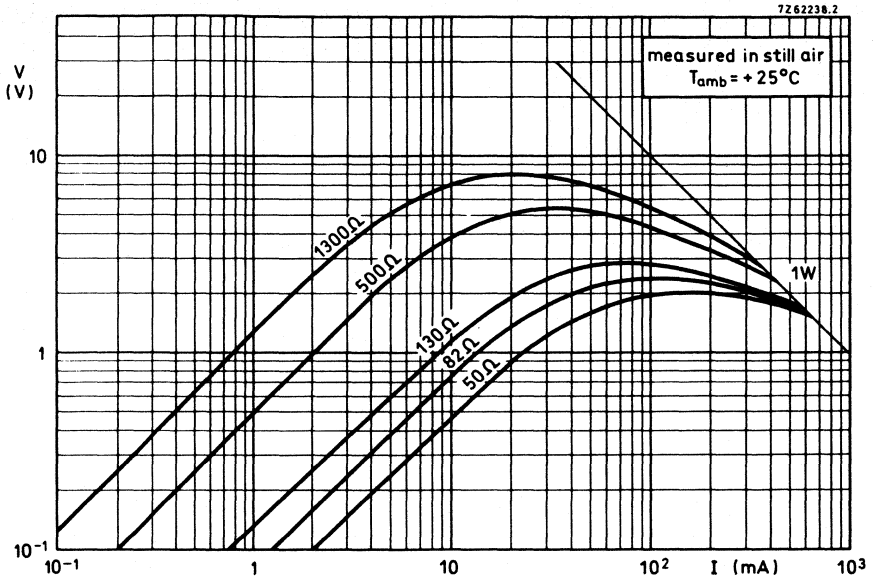

Fig. 2a and b Typical voltage/current characteristics.

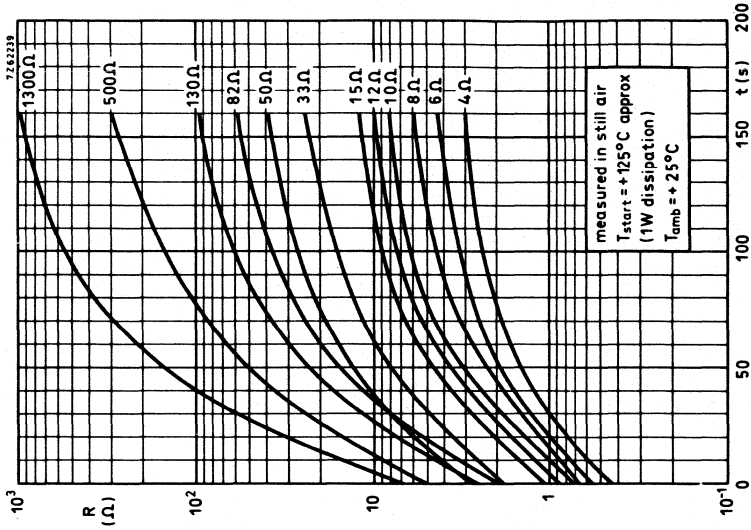

Fig. 4 Typical resistance/time (cooling) characteristics.

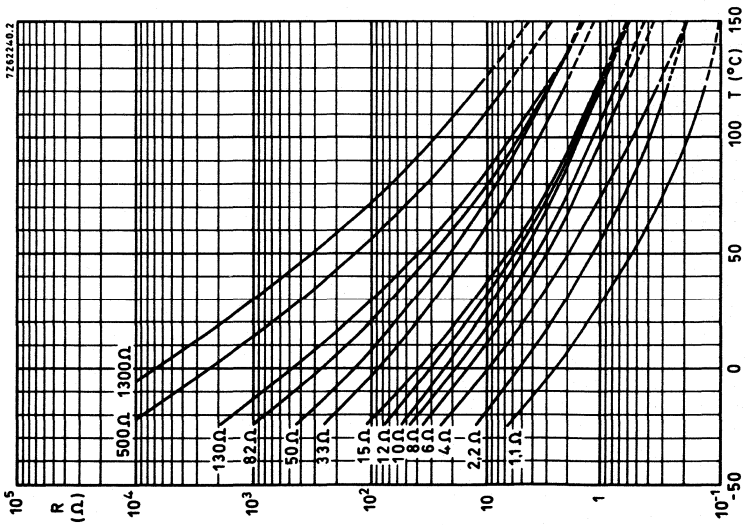

Fig. 3 Typical resistance/temperature characteristics.



## NTC THERMISTORS for motor cars

### APPLICATION

For temperature sensors for the coolant in motor cars. They are also suitable for temperature control in household appliances, such as washing machines.

### DESCRIPTION

Disc thermistors with negative temperature coefficient, without leads. They are specified at a medium temperature (25 to 50 °C) and at a higher temperature (96,5 to 100 °C), so that a high accuracy at the working temperature is obtained (two-point sensor).

R <sub>25</sub> Ω	R <sub>40</sub> Ω	R <sub>50</sub> Ω	R <sub>96,5</sub> Ω	R <sub>100</sub> Ω	diameter mm	catalogue number
2200	1170 ± 12%	342 ± 12,5%	160 ± 8%	64 ± 10%	7,0 ± 0,3	2322 611 90003
930 ± 10%				84,5 ± 7%	5,75 ± 0,25	2322 611 90024
			4,5 ± 0,5	2322 611 90027		

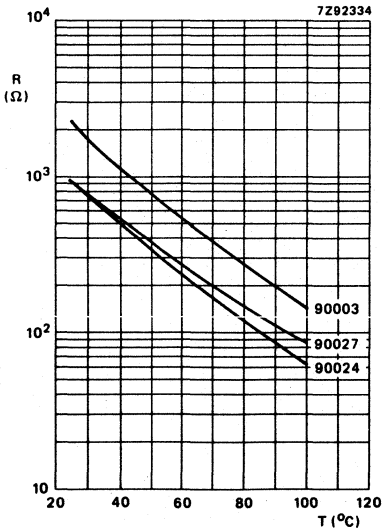

Typical resistance/temperature characteristics.

## NTC THERMISTORS

### miniature bead

#### QUICK REFERENCE DATA

Resistance value at + 25 °C	1 k $\Omega$ to 1 M $\Omega$
B <sub>25/85</sub> -value	2075 to 4100 K
Maximum dissipation	100 mW
Dissipation factor	~ 1,2 mW/K
Thermal time constant	~ 10 s
Operating temperature range at zero power	-25 to + 200 °C, or + 300 °C
at maximum power	0 to + 55 °C

#### APPLICATION

Temperature measurement.

#### DESCRIPTION

Bead thermistor with negative temperature coefficient, in a glass envelope with two tinned dumet (CuNiFe) wires.

#### MECHANICAL DATA

##### Outlines

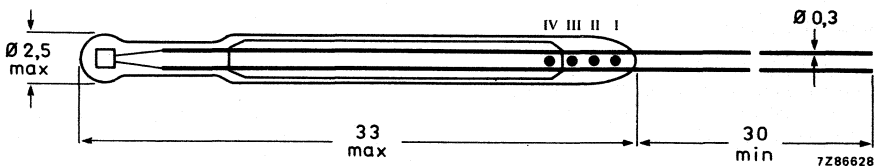

Fig. 1 Maximum bow in the centre of the glass envelope is 1 mm.

##### Marking

Four colour on the glass envelope, see table for colour code.

##### Mass

0,27 g approximately.

##### Mounting

In any position by soldering.

##### Soldering

Solderability max. 240 °C, max. 4 s

Resistance to heat max. 265 °C, max. 11 s

##### Inflammability

Uninflammable.

##### Impact

Free fall 100 mm

**Robustness of terminations**

Tensile strength 2,5 N  
 Bending 1,25 N  
 Resistance to solvents according to IEC 68-2-45, resistant to R113 at T<sub>amb</sub>.

**PACKAGING**

100 thermistors in a cardboard box.

**ELECTRICAL DATA**

Unless otherwise specified, measured according to IEC publication 539.

Table 1 Catalogue number 2322 626 1....

suffix of the catalogue number			R <sub>25</sub> kΩ	B <sub>25/85</sub> -value ± 5% K	temperature coefficient at 25 °C %/K	colour code*		
tol. ± 5%	tol. ± 10%	tol. ± 20%				I	II	III
3102	2102	1102	1	2075	-2,3	brown	black	red
3222	2222	1222	2,2	2285	-2,6	red	red	red
3472	2472	1472	4,7	2485	-2,8	yellow	violet	red
3103	2103	1103	10	2750	-4,2	brown	black	orange
3223	2223	1223	22	3560	-4,0	red	red	orange
3473	2473	1473	47	3750	-4,2	yellow	violet	orange
3104	2104	1104	100	3900	-4,4	brown	black	yellow
3224	2224	1224	220	3860	-4,3	red	red	yellow
3474	2474	1474	470	3950	-4,5	yellow	violet	yellow
3105	2105	1105	1000	4100	-4,6	brown	black	green

\* Thermistors with 5% tolerance have a gold dot IV; 10% tolerance is identified by a silver dot IV, 20% versions have no dot IV (Fig. 1).

- Maximum dissipation at + 55 °C 100 mW
- Dissipation factor ~ 1,2 mW/K
- Thermal time constant ~ 10 s
- Response time (see note) ~ 1 s
- Operating temperature range (Fig. 2 and Table 1)
  - at zero power -25 to + 200 °C, or + 300 °C
  - at maximum power 0 to + 55 °C
- Dielectric withstanding voltage (r.m.s.) between terminals and glass envelope min. 1500 V
- Insulation resistance between terminals and glass envelope at 100 V (d.c.) min. 100 MΩ

Note: Response time in silicone oil MS 200/50. The response time in silicone oil is the time necessary to change of 63,2 % of the total difference between the initial and the final body temperature, when subjected to a step function change in ambient temperature. Step change: initial temperature: air at 25 °C; final temperature: oil (MS 200/50) at 85 °C.

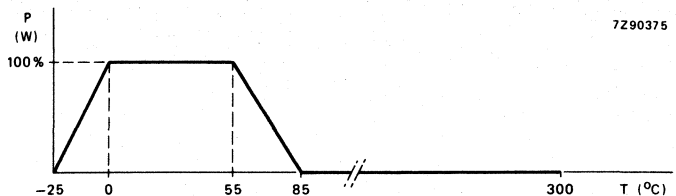

Fig. 2 Derating curve.



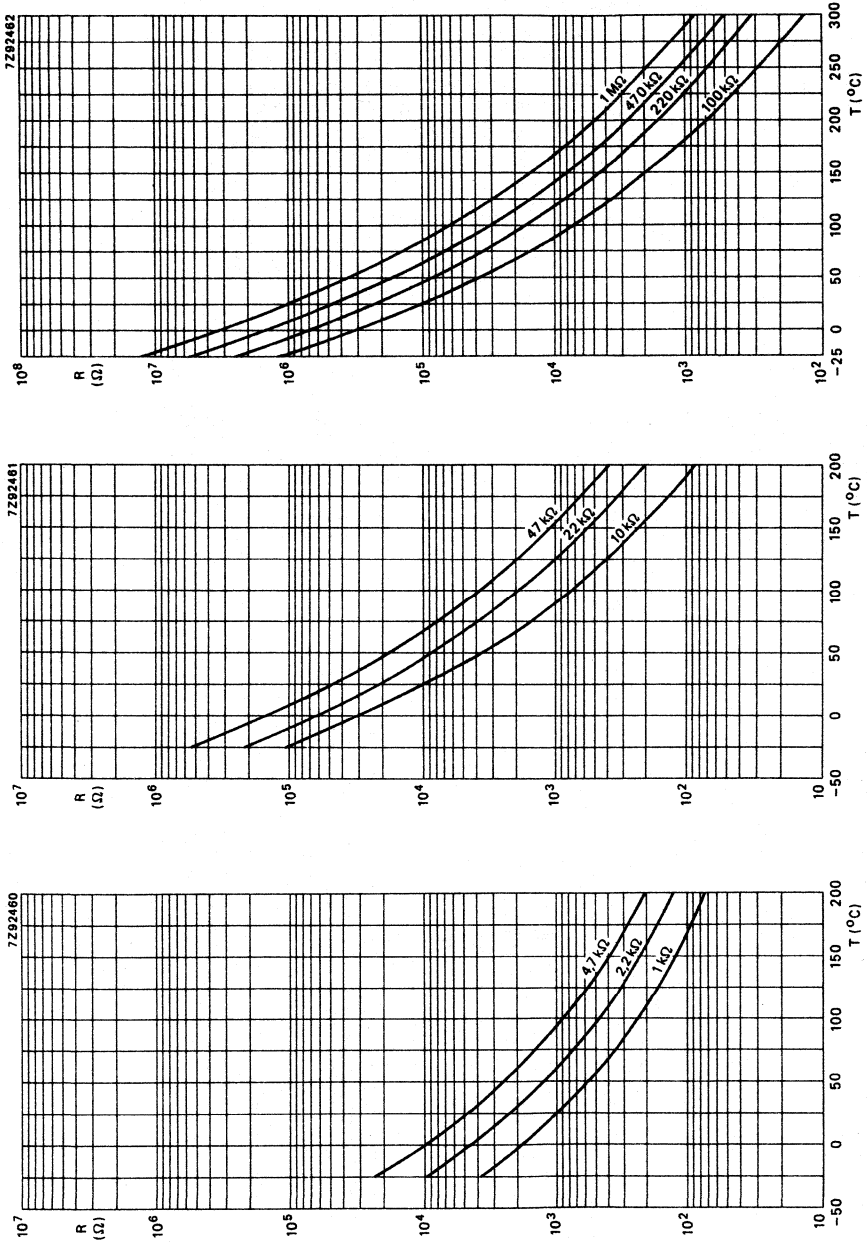

Fig. 3 Typical resistance/temperature characteristics.



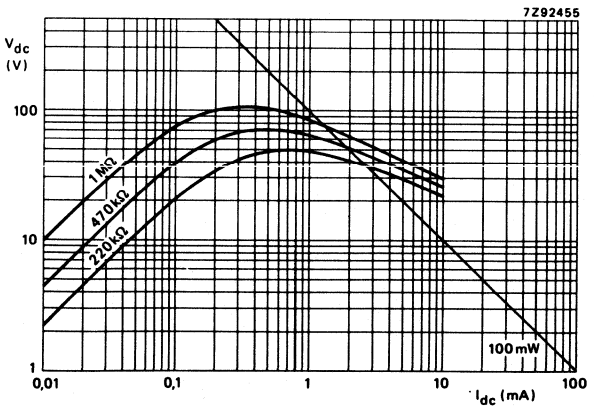
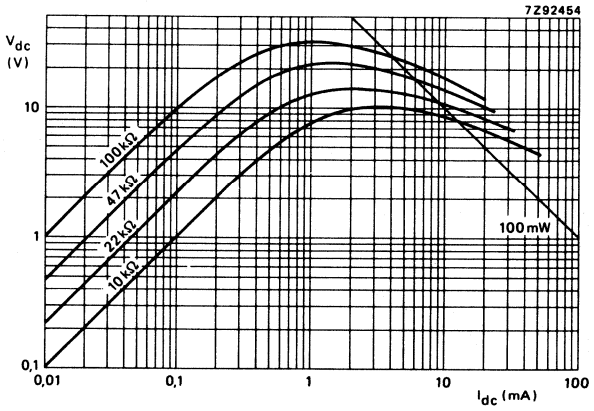
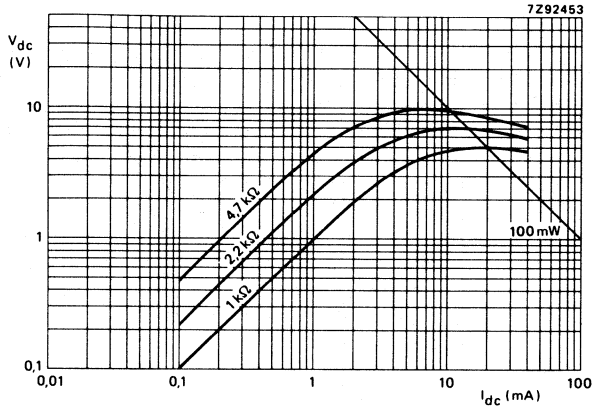

Fig. 4 Typical voltage/current characteristics. Measured in still air at 25 °C.



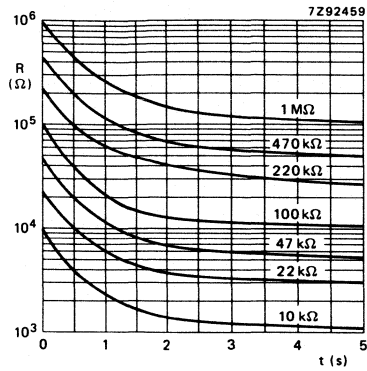
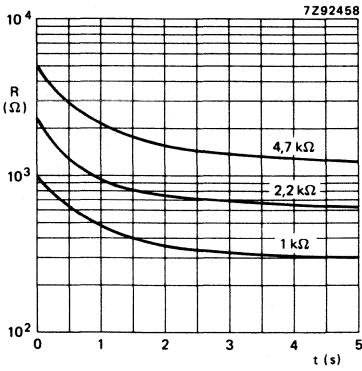

Fig. 5 Typical resistance/response characteristics.  
Temperature step from air at 25 °C to oil at 85 °C.

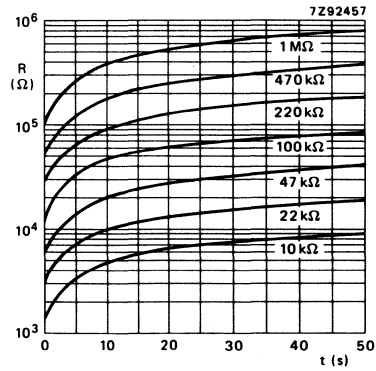
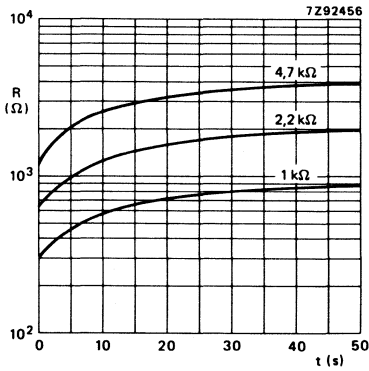

Fig. 6 Typical resistance/cooling time characteristics.  
Measured in still air at 25 °C.  $T_{start} = 85$  °C.





## NTC THERMISTORS

### miniature bead

#### QUICK REFERENCE DATA

Resistance value at + 25 °C	1 k $\Omega$ to 1 M $\Omega$
B25/85-value	2075 to 4100 K
Maximum dissipation	100 mW
Dissipation factor	$\sim 0,8$ mW/K
Thermal time constant	$\sim 7,5$ s
Operating temperature range at zero power	-55 to + 200 °C or + 300 °C
at maximum power	0 to + 55 °C

#### APPLICATION

Temperature measurement.

#### DESCRIPTION

Bead thermistor with negative temperature coefficient, in a glass envelope with two tinned dumet (CuNiFe) wires.

#### MECHANICAL DATA

##### Outlines

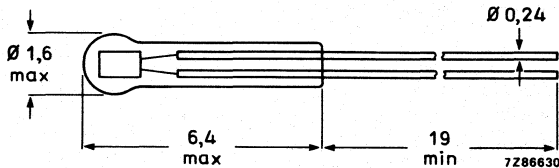

Fig. 1.

##### Marking

None

##### Mass

33 mg approximately

##### Mounting

In any position by soldering.

##### Soldering

Solderability max. 240 °C, max. 4 s

Resistance to heat max. 265 °C, max. 11 s

##### Inflammability

Uninflammable

##### Impact

Free fall 100 mm

**Robustness of terminations**

Tensile strength 1,0 N

**PACKAGING**

100 thermistors in a cardboard box.

**ELECTRICAL DATA**

Unless otherwise specified, measured according to IEC publication 539.

Table 1 Catalogue number 2322 626 2....

suffix of the catalogue number			R25 kΩ	B25/85-value ± 5% K	T <sub>max</sub> °C	temperature coefficient at 25 °C %/K
tol. ± 5%	tol. ± 10%	tol. ± 20%				
3102	2102	1102	1	2075	200	-2,3
3222	2222	1222	2,2	2285	200	-2,6
3472	2472	1472	4,7	2485	200	-2,8
3103	2103	1103	10	3750	200	-4,2
3223	2223	1223	22	3560	200	-4,0
3473	2473	1473	47	3750	200	-4,2
3104	2104	1104	100	3900	300	-4,4
3224	2224	1224	220	3860	300	-4,3
3474	2474	1474	470	3950	300	-4,5
3105	2105	1105	1000	4100	300	-4,6

Maximum dissipation at + 55 °C 100 mW

Dissipation factor ~ 0,8 mW/K

Thermal time constant ~ 7,5 s

Response time (see note) ~ 0,85 s

Operating temperature range (Fig. 2 and Table 1)

at zero power

-55 to + 200 °C, or + 300 °C

at maximum power

0 to + 55 °C

Dielectric withstanding voltage (r.m.s.)

between terminals and glass envelope

min. 100 V

Insulation resistance between terminals

and glass envelope at 10 V (d.c.)

min. 10 MΩ

Note: Response time in silicone oil MS 200/50. The response time in silicone oil is the time necessary to change of 63,2 % of the total difference between the initial and the final body temperature, when subjected to a step function change in ambient temperature. Step change: initial temperature: air at 25 °C; final temperature: oil (MS 200/50) at 85 °C.

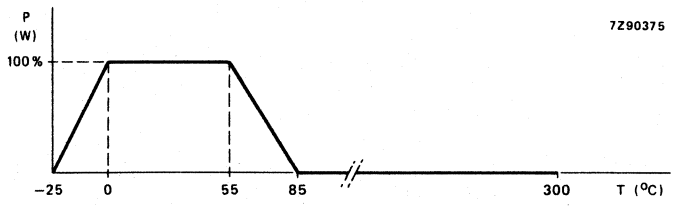

Fig. 2 Derating curve.

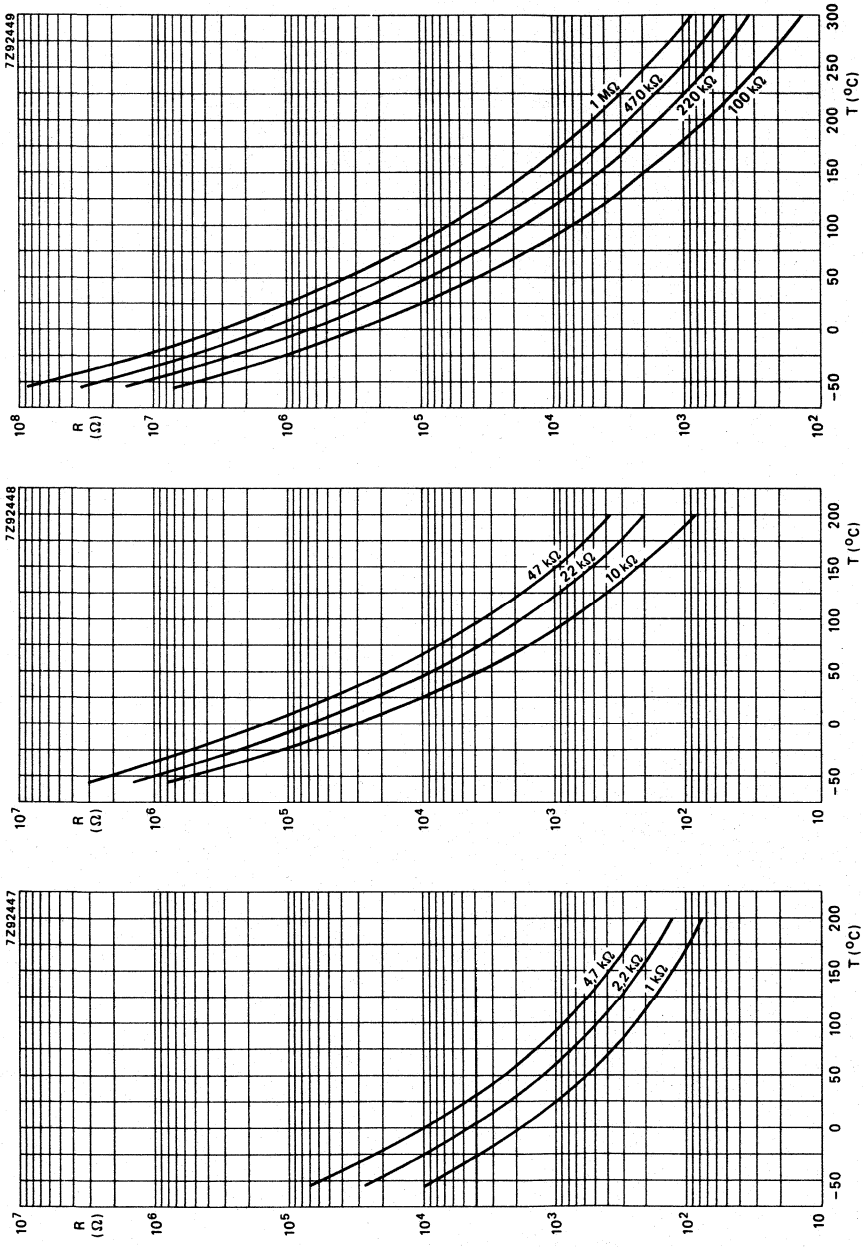

Fig. 3 Typical resistance/temperature characteristics.



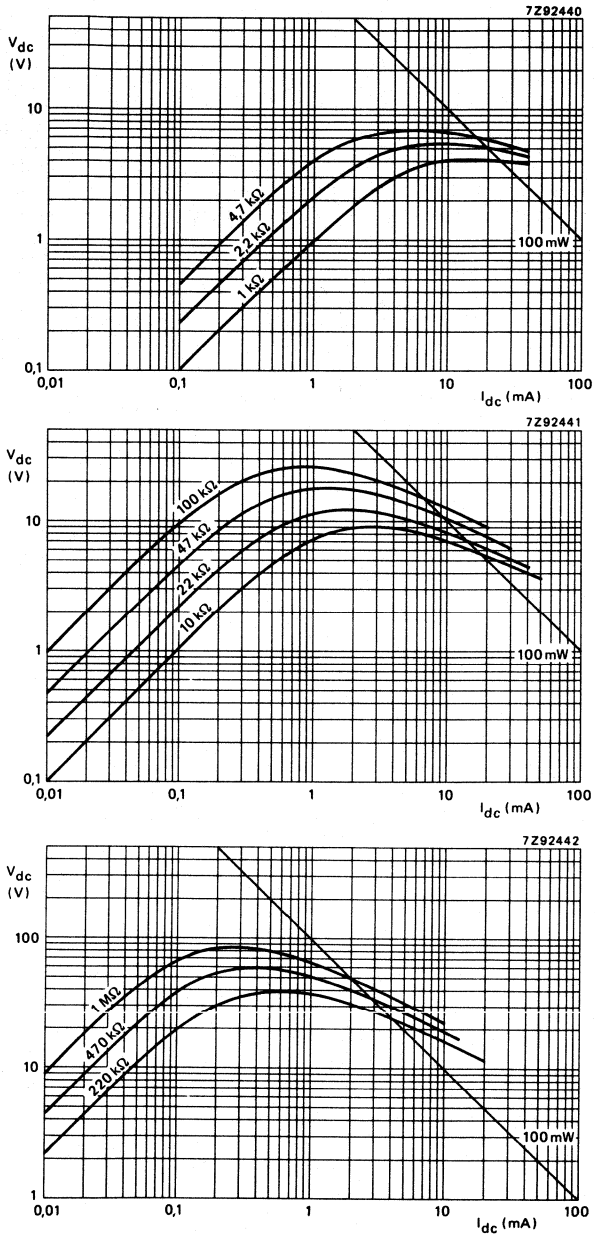

Fig. 4 Typical voltage/current characteristics. Measured in still air at 25 °C.



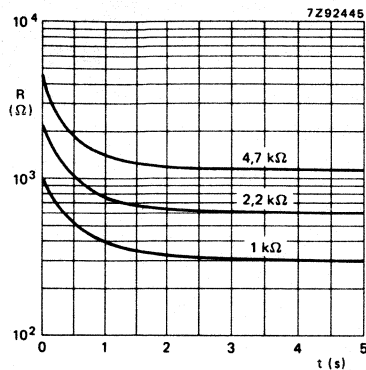
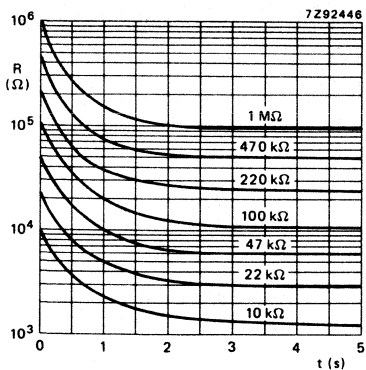

Fig. 5 Typical resistance/response characteristics.  
Temperature step from air at 25 °C to oil at 85 °C.

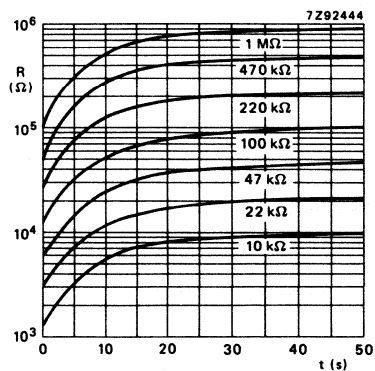
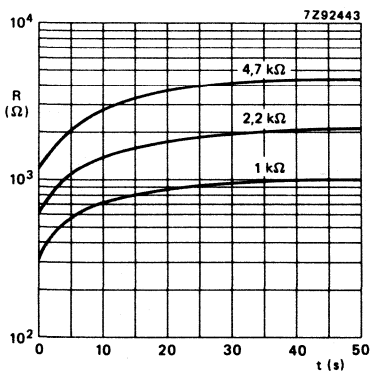

Fig. 6 Typical resistance/cooling time characteristics.  
Measured in still air at 25 °C.  $T_{start} = 85$  °C.



## NTC THERMISTOR

indirectly heated

### QUICK REFERENCE DATA

Resistance at +25 °C	15 k $\Omega$
Resistance of heater	200 $\Omega$
B <sub>25/85</sub> value	3860 K
Maximum dissipation of thermistor at $W_h = 0$ mW	15 mW
Operating temperature range	-25 to +85 °C

### APPLICATION

Compensation in telecommunication amplifiers.

### DESCRIPTION

Miniature thermistor with negative temperature coefficient, indirectly heated and vacuum mounted in a glass bulb.

### MECHANICAL DATA

Unless otherwise specified, measured according to IEC80.

#### Outlines

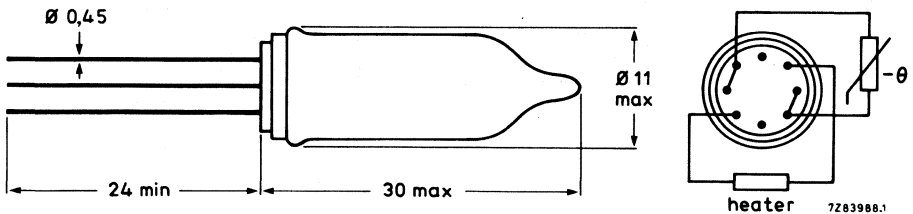

#### Marking

R<sub>17</sub> ( $\pm 2,5$  %) and ratio  $R_{9,5}/R_{17}$  ( $\pm 5$ %).

#### Mass

1,8 g approximately.

#### Mounting

In any position by soldering.

#### Robustness of terminations

Tensile strength	5 N
Bending	2,5 N

#### Soldering

Solderability	max. 240 °C, max. 4 s
Resistance to heat	max. 265 °C, max. 11 s.

**Vibration**

Severity 55 A

**Impact**

Shock severity 50 A  
 Bump severity 40 A/4000  
 Free fall 100 mm

The terminal wires are tinned to max. 2 mm from the glass body, the wires of the heater are provided with a red sleeve.

**ELECTRICAL DATA**

Unless otherwise specified, measured according to IEC draft 40/043/74 of January 1977.

$R_{25} \pm 30\%$	15	$k\Omega$
Maximum resistance at 25 °C and $I_h = 17$ mA	55	$\Omega$
Minimum ratio $R_{9,5}/R_{17}$	7,5	
$R_h \pm 6\%$	200	$\Omega$
B <sub>25/85</sub>	3860	K
Temperature coefficient at +25 °C	~	-4,35 %/K
Maximum dissipation at zero power of heater ( $W_h = 0$ )	15	mW
of thermistor ( $W_{th} = 0$ )	65	mW
Maximum peak dissipation, $W_{th} = 0$	80	mW
Maximum capacitance between heater and thermistor at 1 MHz	6	pF
Operating temperature range	-25 to +85 °C	
Derating curve:		

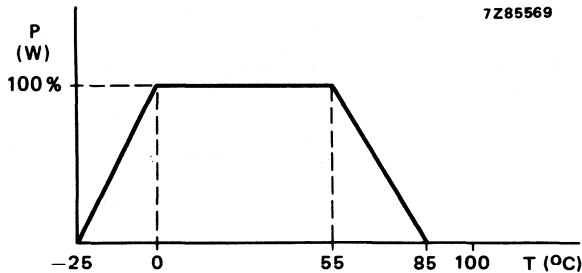

Dielectric withstanding voltage between terminals of thermistor and heater	min.	15 V
Insulation resistance at 10 V (d.c.) and $I_h = 18$ mA, between terminals of thermistor and heater	min.	5 M $\Omega$

**PACKAGING**

200 per cardboard box

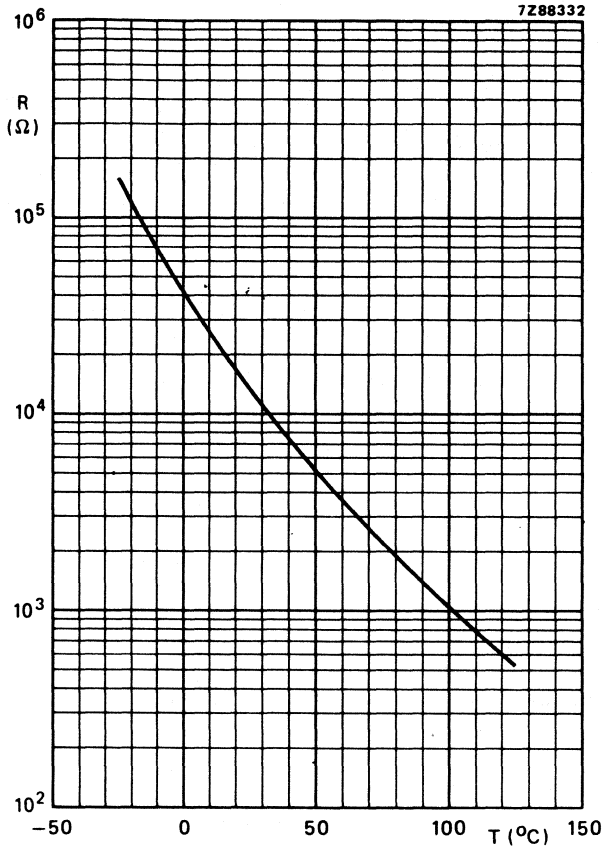

Typical resistance/temperature characteristic.

## NTC THERMISTORS

miniature bead

### QUICK REFERENCE DATA

Resistance value at + 25 °C	1 k $\Omega$ to 1 M $\Omega$
B <sub>25/85</sub> -value	2075 to 4100 K
Operating temperature range at zero power	-55 to + 200 °C

### APPLICATION

Temperature measurement.

### DESCRIPTION

Bead thermistor with negative temperature coefficient, with two solid platinum-iridium leads in opposition or in same direction.

### MECHANICAL DATA

#### Outlines

Fig. 1  
version 2322 633 0....

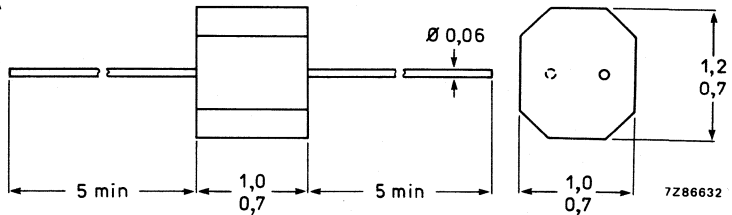
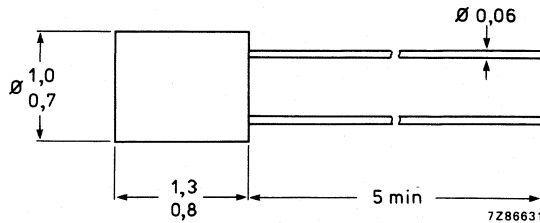

Fig. 2  
version 2322 633 1....



**Marking**  
none.

#### **Mounting**

In any position by spot welding of the leads to conducting wires or other supports.

#### **Mass**

5 mg. approximately.

#### **Inflammability**

Uninflammable.

### PACKAGING

100 thermistors in a cardboard box.

2322 633 0....  
2322 633 1....

**ELECTRICAL DATA**

Unless otherwise specified, measured according to IEC publication 539.

catalogue number				R <sub>25</sub>	temperature coefficient at 25 °C	B <sub>25/85</sub> -value ± 5%
2322 633 0.... leads in opposition		2322 633 1.... leads in same direction				
tol. ± 5%	tol. ± 10%	tol. ± 5%	tol. ± 10%	kΩ	%/K	K
3102	2102	3102	2102	1	-2,3	2075
3222	2222	3222	2222	2,2	-2,6	2285
3472	2472	3472	2472	4,7	-2,8	2485
3103	2103	3103	2103	10	-4,2	3750
3223	2223	3223	2223	22	-4,0	3560
3473	2473	3473	2473	47	-4,2	3750
3104	2104	3104	2104	100	-4,4	3900
3224	2224	3224	2224	220	-4,1	3860
3474	2474	3474	2474	470	-4,5	3950
3105	2105	3105	2105	1000	-4,6	4100

Operating temperature range, at zero power

-55 to +200 °C



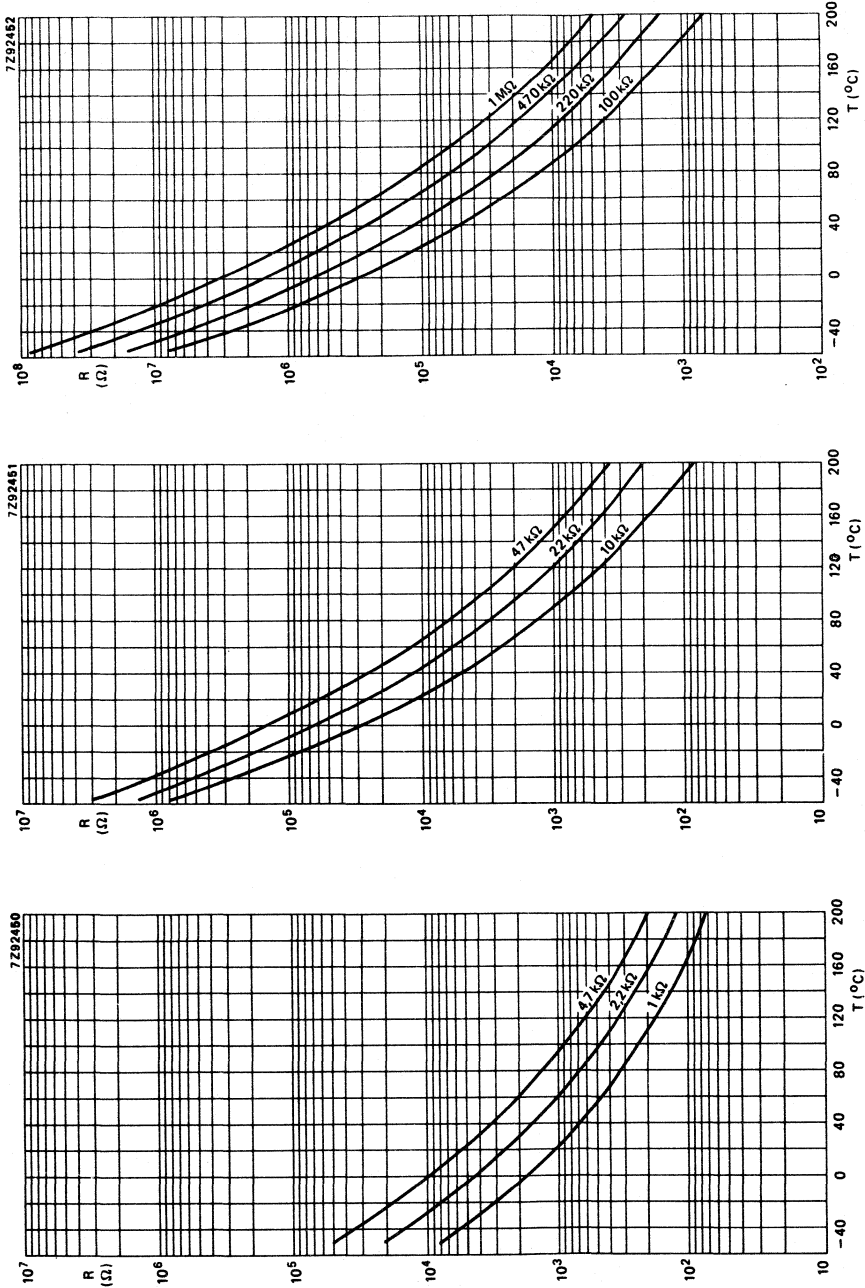

Fig. 3 Typical resistance/temperature characteristics.







## NTC THERMISTORS

### miniature bead

#### QUICK REFERENCE DATA

Resistance value at + 25 °C	1 k $\Omega$ to 1 M $\Omega$
B <sub>25/85</sub> -value	2075 to 4100 K
Maximum dissipation	60 mW
Dissipation factor	~ 0,5 mW/K
Thermal time constant	~ 5,5 s
Operating temperature range at zero power	-55 to + 200 °C
at maximum power	0 to + 55 °C

#### APPLICATION

Temperature measurements.

#### DESCRIPTION

Bead thermistor with negative temperature coefficient, in a glass envelope with two tinned dumet (CuNiFe) wires.

#### MECHANICAL DATA

##### Outlines

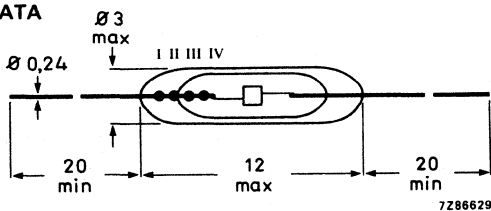

Fig. 1.

##### Marking

Colour dots on the glass envelope, see Fig. 1 and Table 1.

##### Mass

0,1 g approximately.

##### Mounting

In any position by soldering.

##### Soldering

Solderability max. 240 °C, max. 4 s

Resistance to heat max. 265 °C, max. 11 s

##### Inflammability

Uninflammable.

##### Impact

Free fall 100 mm

**Robustness of terminations**

Tensile strength 1,0 N  
 Bending 0,5 N  
 Torsion 3 times

Resistance to solvents: according to IEC 68-2-45, resistant to R113 at T<sub>amb</sub>

**Packaging**

100 thermistors in a cardboard box.

**ELECTRICAL DATA**

Unless otherwise specified, measured according to IEC publication 539.

Table 1 Catalogue number 2322 633 2....

suffix of the catalogue number			R <sub>25</sub> kΩ	B <sub>25/85</sub> -value ± 5% K	temperature coefficient at 25 °C %/K	colour code*		
tol. ± 5%	tol. ± 10%	tol. ± 20%				I	II	III
3102	2102	1102	1	2075	-2,3	brown	black	red
3222	2222	1222	2,2	2285	-2,6	red	red	red
3472	2472	1472	4,7	2485	-2,8	yellow	violet	red
3103	2103	1103	10	3750	-4,2	brown	black	orange
3223	2223	1223	22	3560	-4,0	red	red	orange
3473	2473	1473	47	3750	-4,2	yellow	violet	orange
3104	2104	1104	100	3900	-4,4	brown	black	yellow
3224	2224	1224	220	3860	-4,3	red	red	yellow
3474	2474	1474	470	3950	-4,5	yellow	violet	yellow
3105	2105	1105	1000	4100	-4,6	brown	black	green

\* Thermistors with 5% tolerance have a gold dot IV; 10% tolerance is identified by a silver dot IV, 20% versions have no dot IV (Fig. 1).

Maximum dissipation at + 55 °C 60 mW  
 Dissipation factor ~ 0,5 mW/K  
 Thermal time constant ~ 5,5 s  
 Operating temperature range (Fig. 2)  
 at zero power -55 to + 200 °C  
 at maximum power 0 to + 55 °C  
 Dielectric withstanding voltage (r.m.s.)  
 between terminals and glass envelope min. 1500 V  
 Insulation resistance between terminals  
 and glass envelope at 100 V (d.c.) min. 100 MΩ

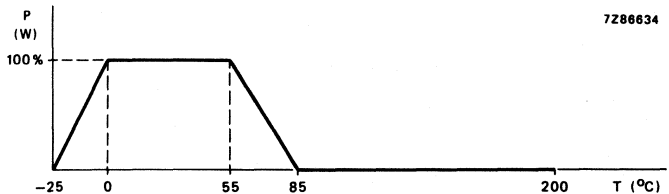

Fig. 2 Derating curve.

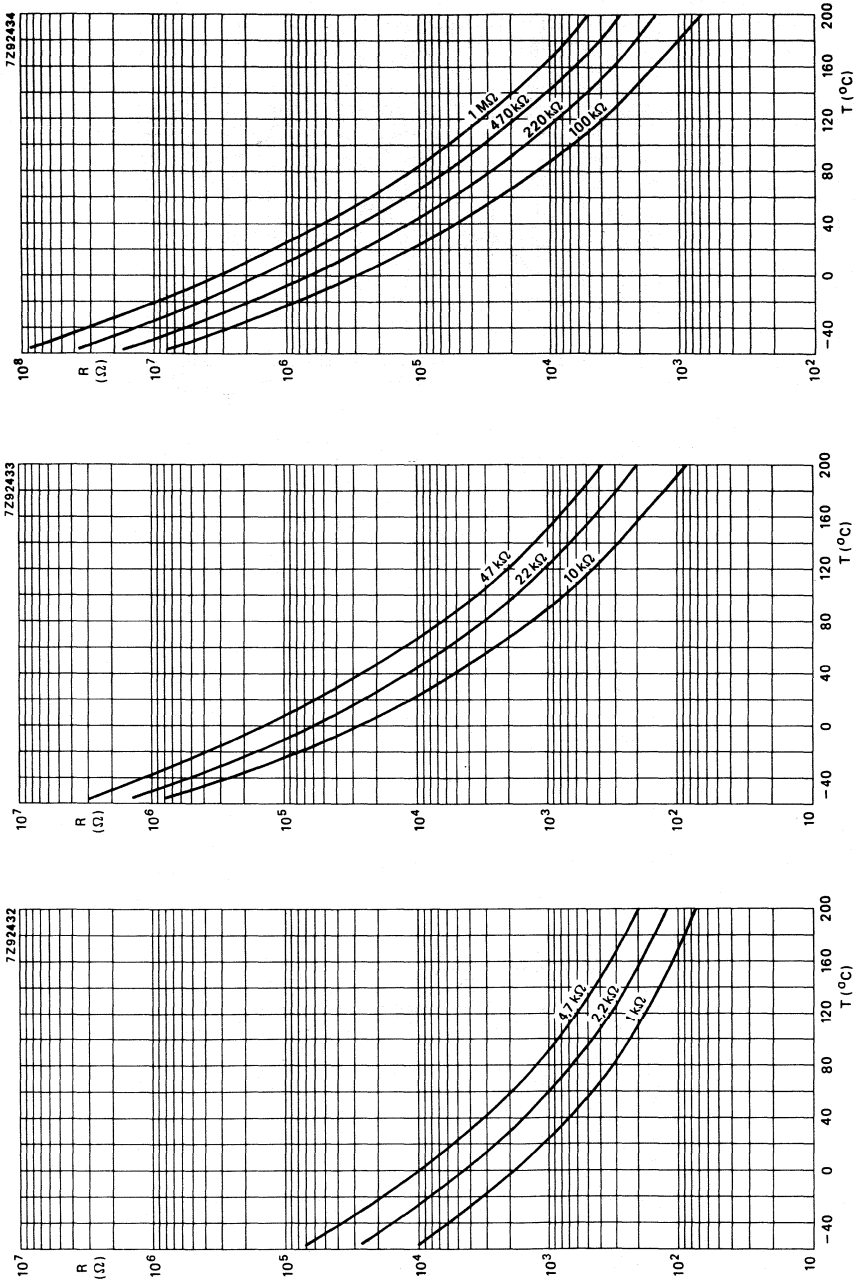

Fig. 3 Typical resistance/temperature characteristics.



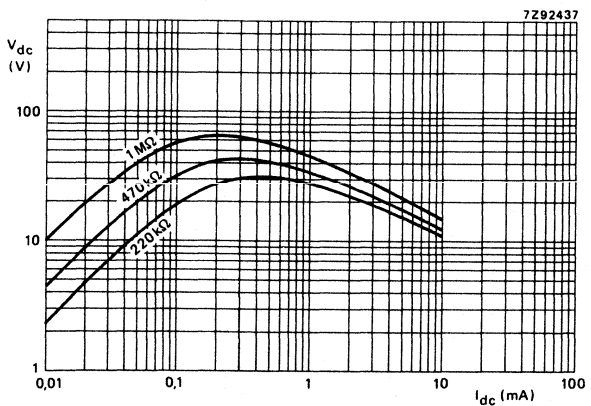
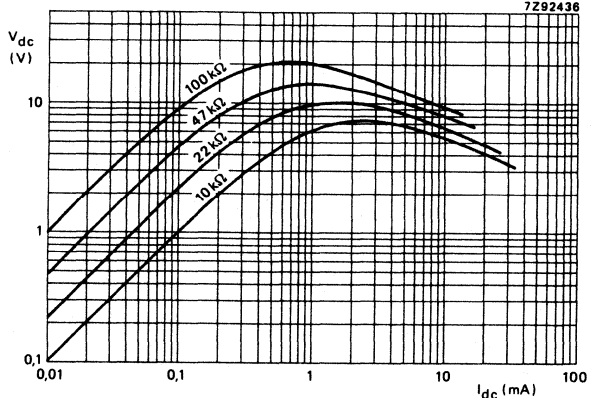
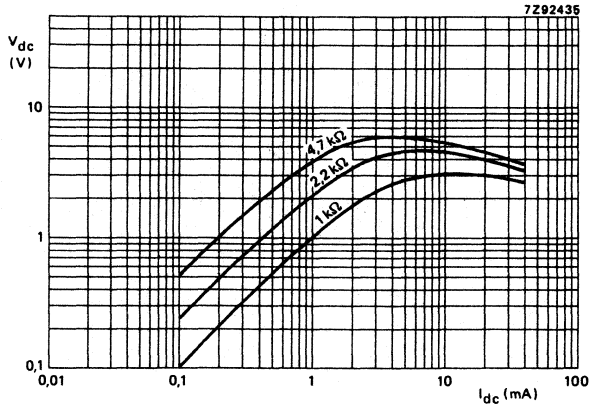

Fig. 4 Typical voltage/current characteristic. Measured in still air at 25 °C.

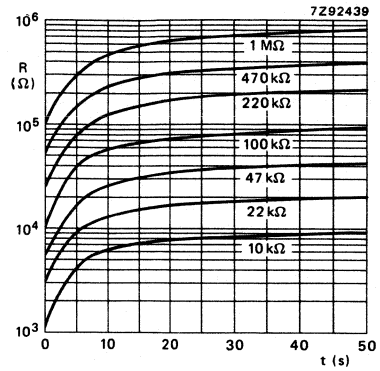
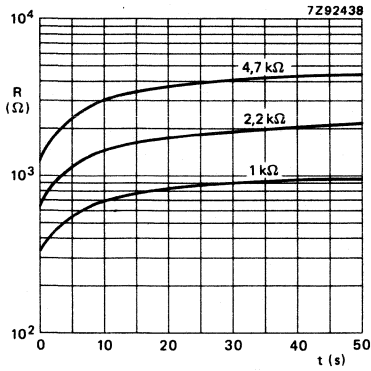

Fig. 5 Typical resistance/cooling characteristics.  
Measured in still air at 25 °C.  $T_{start} = 85$  °C.





## NTC THERMISTORS

rod

### QUICK REFERENCE DATA

Resistance values at + 25 °C	4,7 k $\Omega$ to 470 k $\Omega$
R <sub>25/85</sub> -value	3300 to 4300 K
Maximum dissipation	0,6 W
Dissipation factor	5 mW/°C
Thermal time constant	30 s
Operating temperature range	
at zero power	-25 to + 155 °C
at maximum power	0 to + 55 °C

### APPLICATION

General purpose.

### DESCRIPTION

Rod thermistors with a negative temperature coefficient with two tangential tinned copper wires. They are neither lacquered nor insulated.

### MECHANICAL DATA

#### Outlines

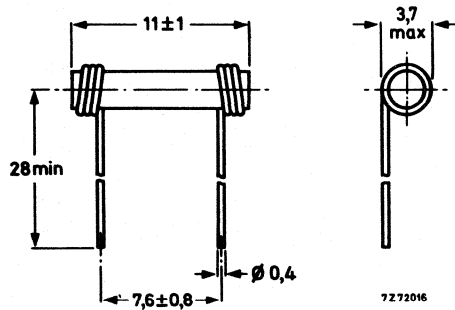

Fig. 1.

#### Marking

The thermistors have one or two colour dots in the middle of the rod, see table. Types with a tolerance of 10% on R<sub>25</sub> also have a red dot at one end.

**Mass** 0,32 g approximately.

**Mounting** In any position by soldering.

**Robustness of terminations**

Tensile strength 5 N  
 Bending 2,5 N

**Soldering**

Solderability max. 240 °C, max. 4 s  
 Resistance to heat max. 265 °C, max. 11 s.

**PACKAGING**

250 thermistors in a cardboard box.

**ELECTRICAL DATA**

Unless otherwise specified measured according to IEC publication 539.

catalogue number		R <sub>25</sub>	R <sub>25/85</sub>	temperature coefficient *	colour ** code
tol. ± 20%	tol. ± 10% **	kΩ	± 5% K		
2322 635 01472	2322 635 02472	4,7	3300	-3,70	orange
2332 635 01153	2322 635 02153	15	3600	-4,05	green
2322 635 01473	2322 635 02473	47	3925	-4,25	blue
2322 635 01154	2322 635 02154	150	4075	-4,65	white
→ 2322 635 01334▲	2322 635 02334▲	330	4250	-4,85	yellow/blue
→ 2322 635 01474▲	2322 635 02474▲	470	4300	-4,75	yellow/orange

Maximum dissipation 0,6 W  
 Dissipation factor 5 mW/K  
 Thermal time constant 30 s  
 Heat capacity of ceramic of complete component 0,135 J/K  
 0,150 J/K  
 Operating temperature range at zero power -25 to + 155 °C  
 at maximum power 0 to + 55 °C

▲ Maintenance type.

\* Approximate values, measured in the test set, according to NFC93-271.

\*\* See "Marking".



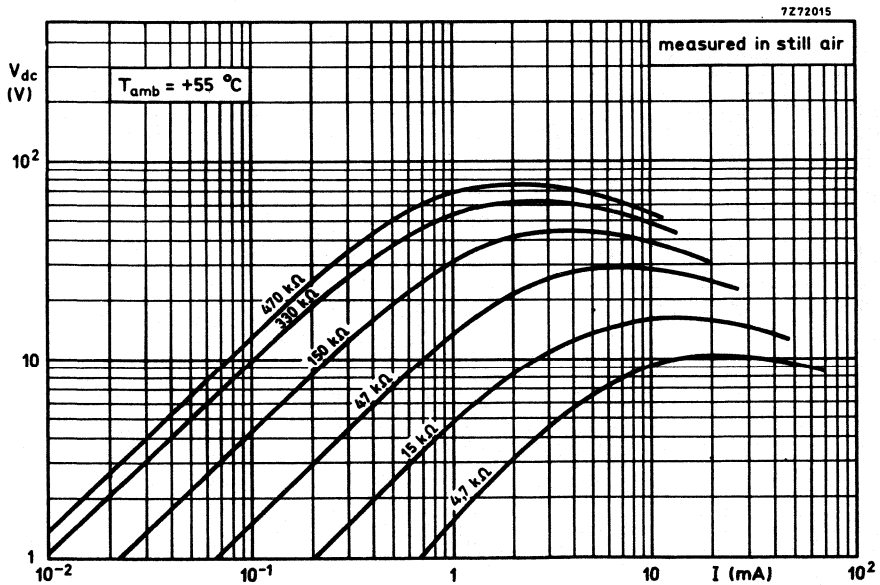
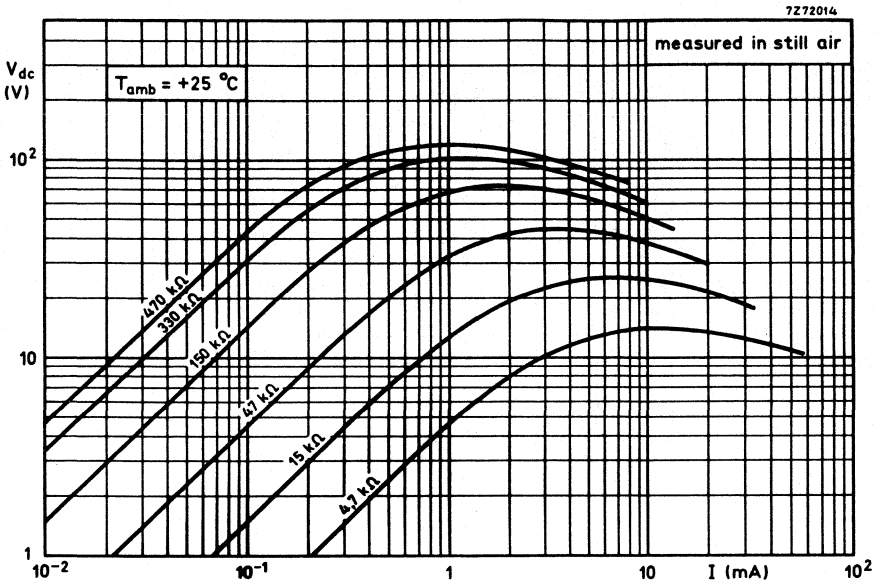

Fig. 2a and b Typical voltage/current characteristics.

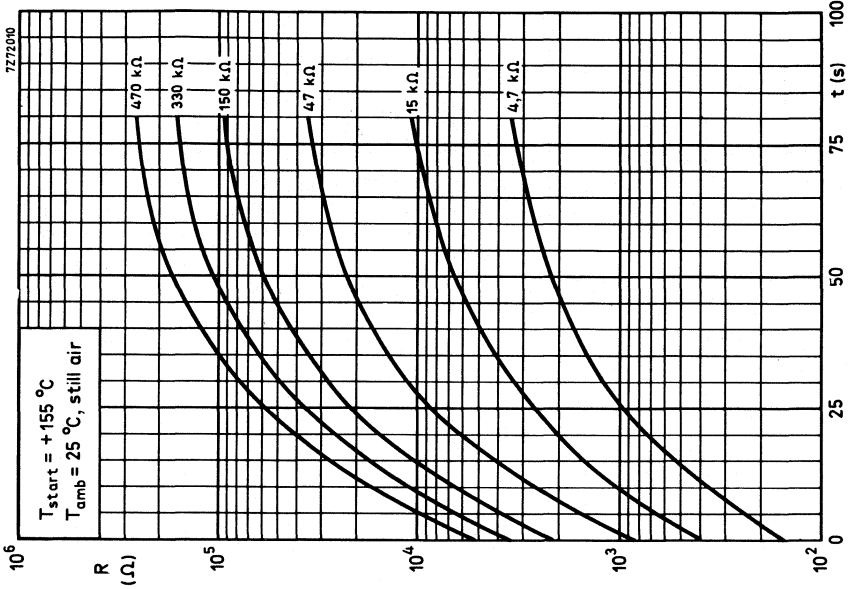

Fig. 4 Typical resistance/time (cooling) characteristics.

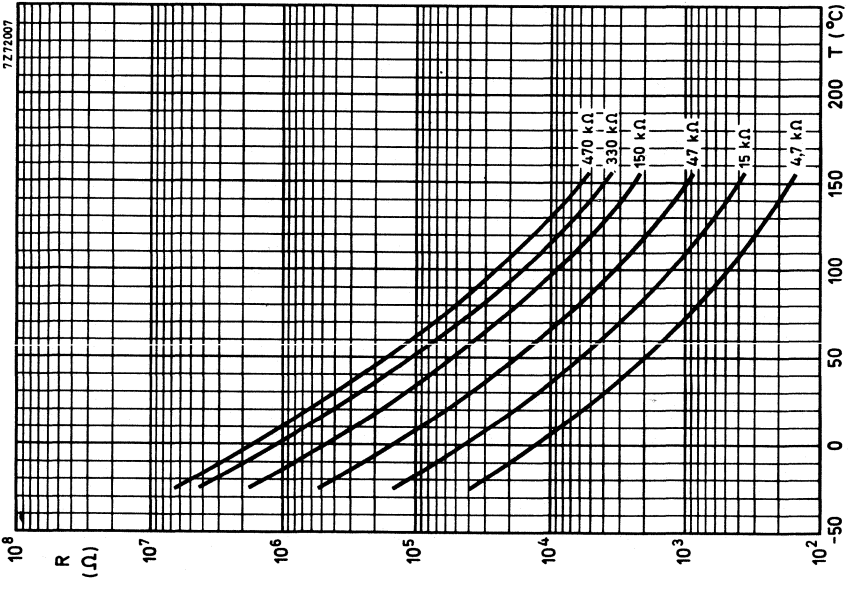

Fig. 3 Typical resistance/temperature characteristics.

## NTC THERMISTORS

rod

### QUICK REFERENCE DATA

Resistance values at + 25 °C	4,7 k $\Omega$ to 150 k $\Omega$
B <sub>25/85</sub> -value	3250 to 4150 K
Maximum dissipation	1,5 W
Dissipation factor	10 mW/K
Thermal time constant	55 s
Operating temperature range at zero power	-25 to + 155 °C
at maximum power	0 to + 55 °C

### APPLICATION

General purpose.

### DESCRIPTION

Rod thermistors with a negative temperature coefficient, with two tangential tinned copper wires. They are neither lacquered nor insulated.

### MECHANICAL DATA

Outlines

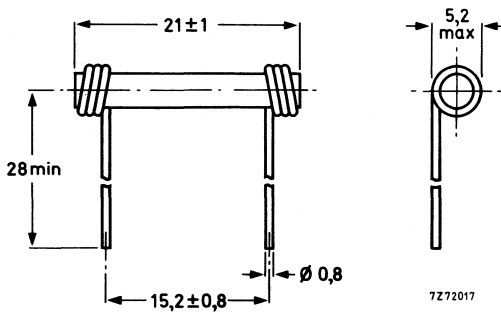

Fig. 1.

### Marking

The thermistors have a colour dot in the middle of the rod, see table. Types with a tolerance of 10% on R<sub>25</sub> also have a red dot at one end.

**Mass** 1,25 g approximately.

**Mounting** In any position by soldering.

**Robustness of terminations**

Tensile strength	20 N
Bending	10 N

**Soldering**

Solderability	max. 240 °C, max. 4 s
Resistance to heat	max. 265 °C, max. 11 s

**PACKAGING**

200 thermistors in a cardboard box.

**ELECTRICAL DATA**

Unless otherwise specified, measured according to IEC publication 539.

catalogue number		R <sub>25</sub> kΩ	B <sub>25/85</sub> ± 5% K	temperature coefficient * %/K	colour ** code
tol. ± 20%	tol. ± 10% **				
2322 636 01472	2322 636 02472	4,7	3250	-3,55	orange
2322 636 01153	2322 636 02153	15	3550	-4,0	green
2322 636 01473	2322 636 02473	47	4000	-4,5	blue
2322 636 01154	2322 636 02154	150	4150	-4,65	white

Maximum dissipation	1,5 W
Dissipation factor	10 mW/K
Thermal time constant	55 s
Heat capacity of ceramic	0,44 J/K
of complete component	0,55 J/K
Operating temperature range at zero power	-25 to + 155 °C
at maximum power	0 to + 55 °C

\* Approximate values, measured in the test set according to NF C93-271.

\*\* See "marking".

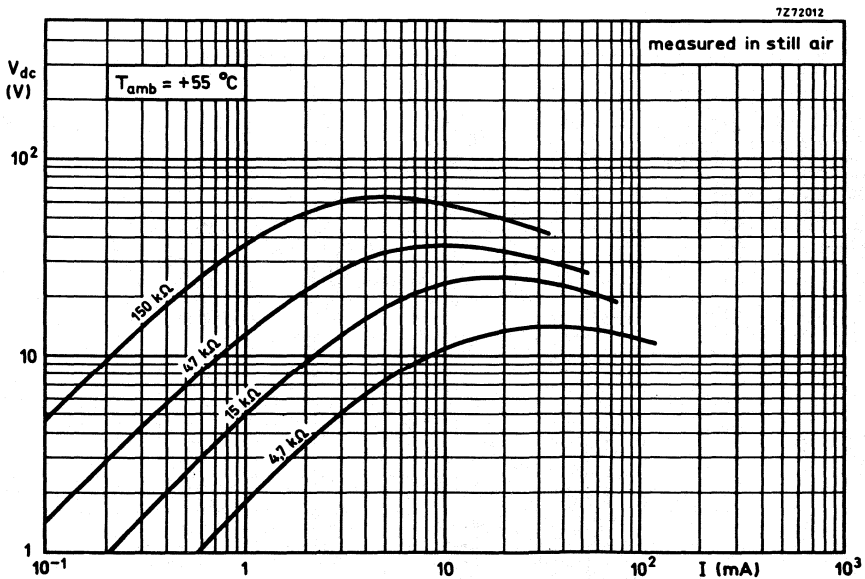
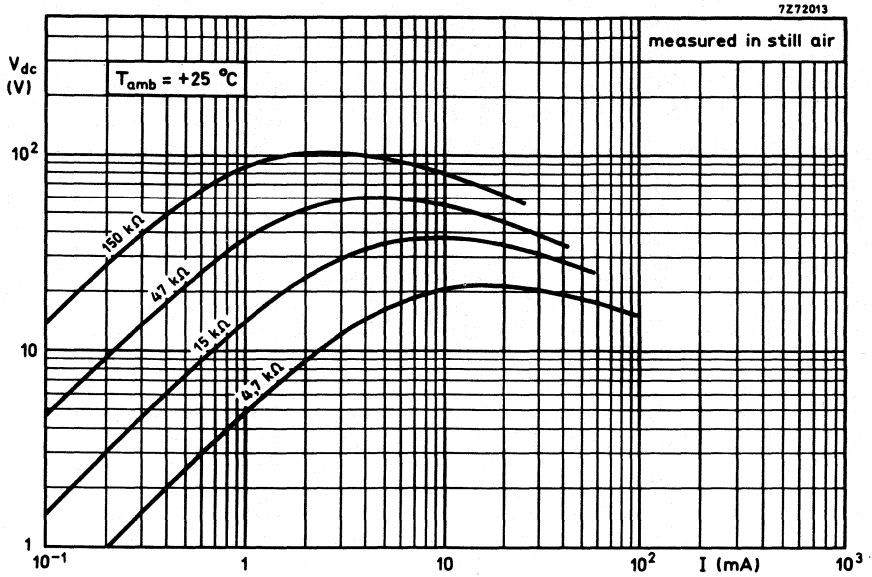

Fig. 2a and b Typical voltage/current characteristics.

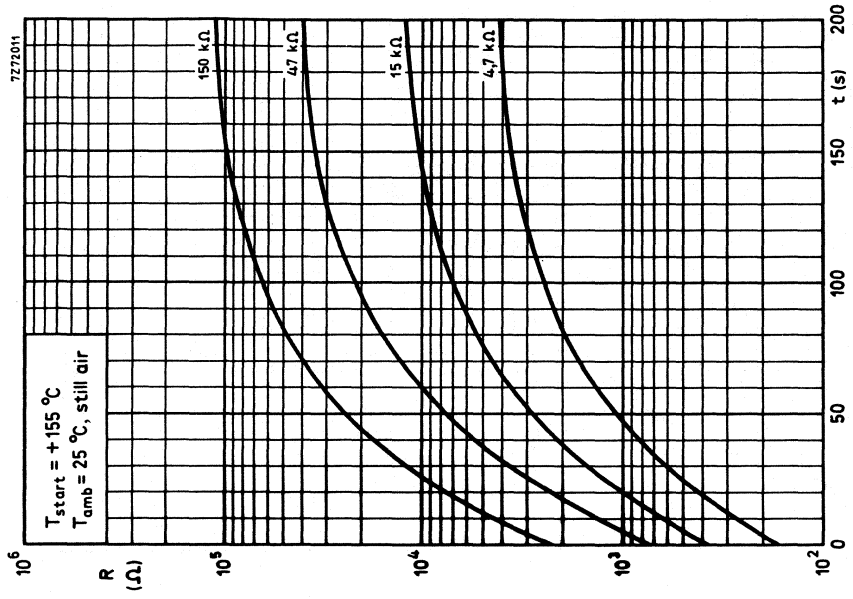

Fig. 4 Typical resistance/time (cooling) characteristics.

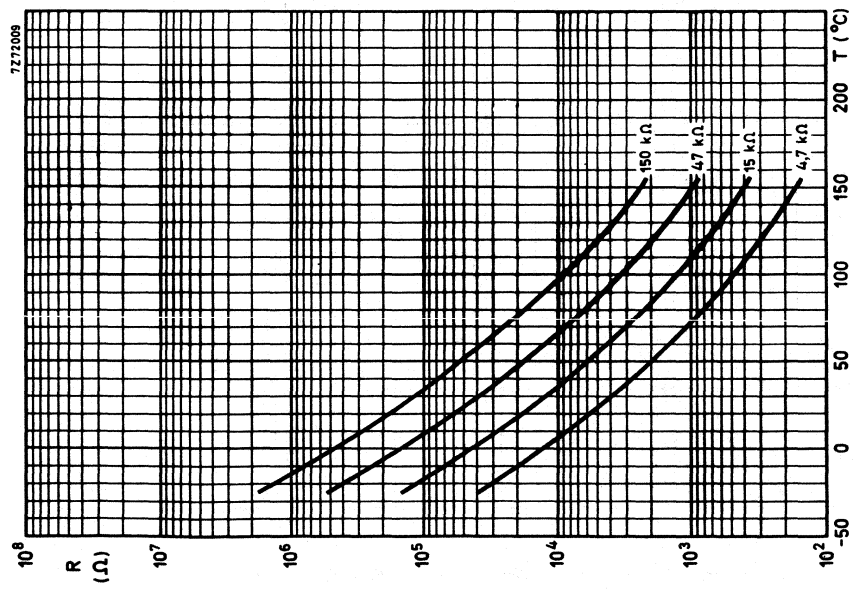

Fig. 3 Typical resistance/temperature characteristics.

## NTC THERMISTORS

rod

### QUICK REFERENCE DATA

Resistance values at + 25 °C	4,7 kΩ to 150 kΩ
B <sub>25/85</sub> -value	3200 to 4200 K
Maximum dissipation	2,3 W
Dissipation factor	17 mW/K
Thermal time constant	105 s
Operating temperature range at zero power	-25 to + 155 °C
at maximum power	0 to +55 °C

### APPLICATION

General purpose.

### DESCRIPTION

Rod thermistors with a negative temperature coefficient, with two tangential tinned copper wires. They are neither lacquered nor insulated.

### MECHANICAL DATA

Outlines

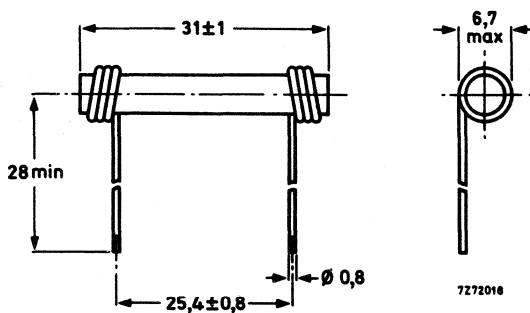

Fig. 1.

### Marking

The thermistors have a colour dot in the middle of the rod, see table. Types with a tolerance of 10% on R<sub>25</sub> also have a red dot at one end.

**Mass** 2,65 g approximately

**Mounting** In any position by soldering.

**Robustness of terminations**

Tensile strength	20 N
Bending	10 N

**Soldering**

Solderability	max. 240 °C, max. 4 s
Resistance to heat	max. 265 °C, max. 11 s

**PACKAGING**

50 thermistors in a cardboard box

**ELECTRICAL DATA**

Unless otherwise specified, measured according to IEC publication 539.

catalogue number		R <sub>25</sub> %/K	R <sub>25/85</sub> ± 5% K	temperature coefficient * %/K	colour ** code
tol. ± 20%	tol. ± 10% **				
2322 637 01472	2322 637 02472	4,7	3200	-3,6	orange
2322 637 01153	2322 637 02153	15	3550	-4,0	green
2322 637 01473	2322 637 02473	47	4000	-4,2	blue
2322 637 01154	2322 637 02154	150	4200	-4,7	white

Maximum dissipation	2,3 W	}	*
Dissipation factor	17 mW/K		
Thermal time constant	105 s		
Heat capacity	1,785 J/K		
Operating temperature range			
at zero power	-25 to + 155 °C		
at maximum power	0 to + 55 °C		

\* Approximate values, measured in the test set according to NF C 93-271.

\*\* See "marking".



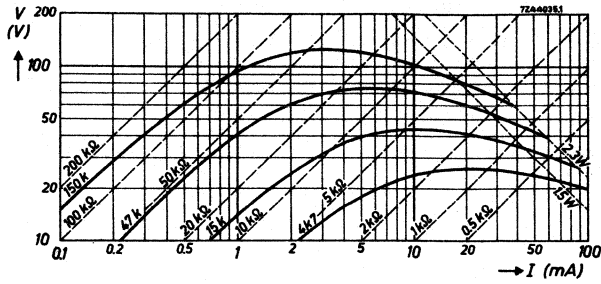

Fig. 2 Typical voltage/current characteristics.

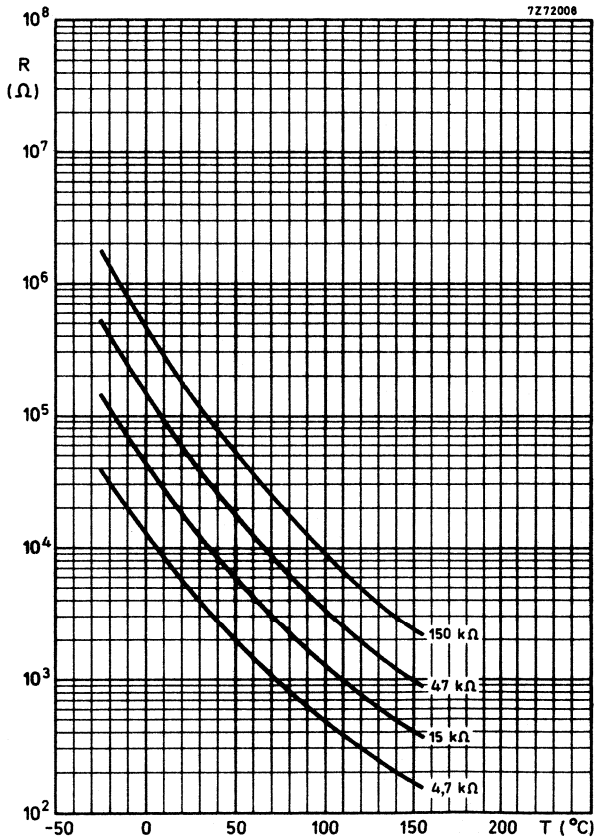

Fig. 3 Typical resistance/temperature characteristics.





## NTC THERMISTORS

### QUICK REFERENCE DATA

Resistance value at +25 °C	2,7 to 330 k $\Omega$
B <sub>25/85</sub> value	3660 to 4150 K
Maximum dissipation	0,25 W
Dissipation factor	7,5 mW/K
Thermal time constant	19 s
Operating temperature range at zero power	-25 to +125 °C
at maximum power	0 to +55 °C

### APPLICATION

General purpose.

### DESCRIPTION

The thermistor has a negative temperature coefficient. It consists of a disc with two tinned copper wires. It is grey lacquered and colour coded, but not insulated.

### MECHANICAL DATA

#### Outlines

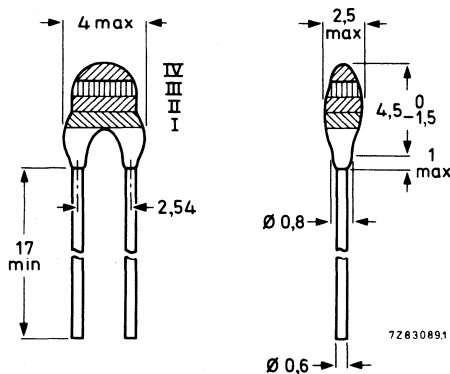

Fig. 1.

**Marking**

The thermistors are marked with colour bands in accordance with Fig. 1 and Table 1.

**Mass**

0,14 g approximately.

**Mounting**

In any position by soldering

**Robustness of terminations**

Tensile strength 10 N

Bending 5 N

**Soldering**

Solderability max. 240 °C, max. 4 s

Resistance to heat max. 265 °C, max. 11 s

**Impact**

Free fall 1 m

**Uninflammable****Resistant to solvents**

According to IEC 68-2-45, resistant to R113 at  $T_{amb}$

**PACKAGING**

500 thermistors in a cardboard box.

**ELECTRICAL DATA**

Unless otherwise specified, measured according to IEC publication 539.

Maximum dissipation at  $T_{amb} = +55\text{ °C}^*$

0,25 W

Dissipation factor\*

7,5 mW/K approx.

Thermal time constant \*

19 s approx.

Heat capacity\*

0,135 J/K approx.

Operating temperature range

at zero power

-25 to +125 °C

at maximum power

0 to +55 °C

\* Measured in the measuring set described in the French norm NF C93-271, and clamped at 10 mm from the body.

Table 1

catalogue number 2322 640 1....		R <sub>25</sub>	B <sub>25/85</sub> ± 5%	B <sub>-25/25</sub> ± 5%	temperature coefficient at +25 °C %/K	colour code *		
R <sub>25</sub> ± 5%	R <sub>25</sub> ± 10%	Ω	K	K		I	II	III
3272	2272	2 700	4000	3800	-4,50	red	violet	red
3472	2472	4 700	3660	3440	-4,12	yellow	violet	red
3123	2123	12 000	3700	3540	-4,17	brown	red	orange
3223	2223	22 000	3700	3420	-4,17	red	red	orange
3473	2473	47 000	3850	3570	-4,33	yellow	violet	orange
3683	2683	68 000	3880	3590	-4,37	blue	grey	orange
3154 ▲	2154 ▲	150 000	4050	3740	-4,56	brown	green	yellow
3334	2334	330 000	4150	3830	-4,67	orange	orange	yellow

▲ Maintenance type.

\* Thermistors with a 5% tolerance have a gold band IV; 10% tolerance is identified by a silver band IV (Fig. 1). If band IV is not used see 2322 640 19...

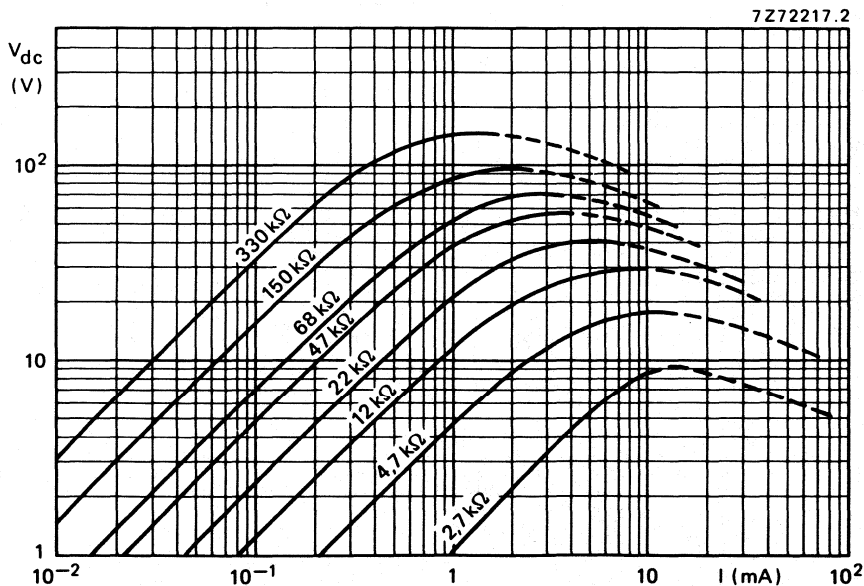

Fig. 2 Typical voltage/current characteristics. T<sub>amb</sub> = +25 °C, still air.



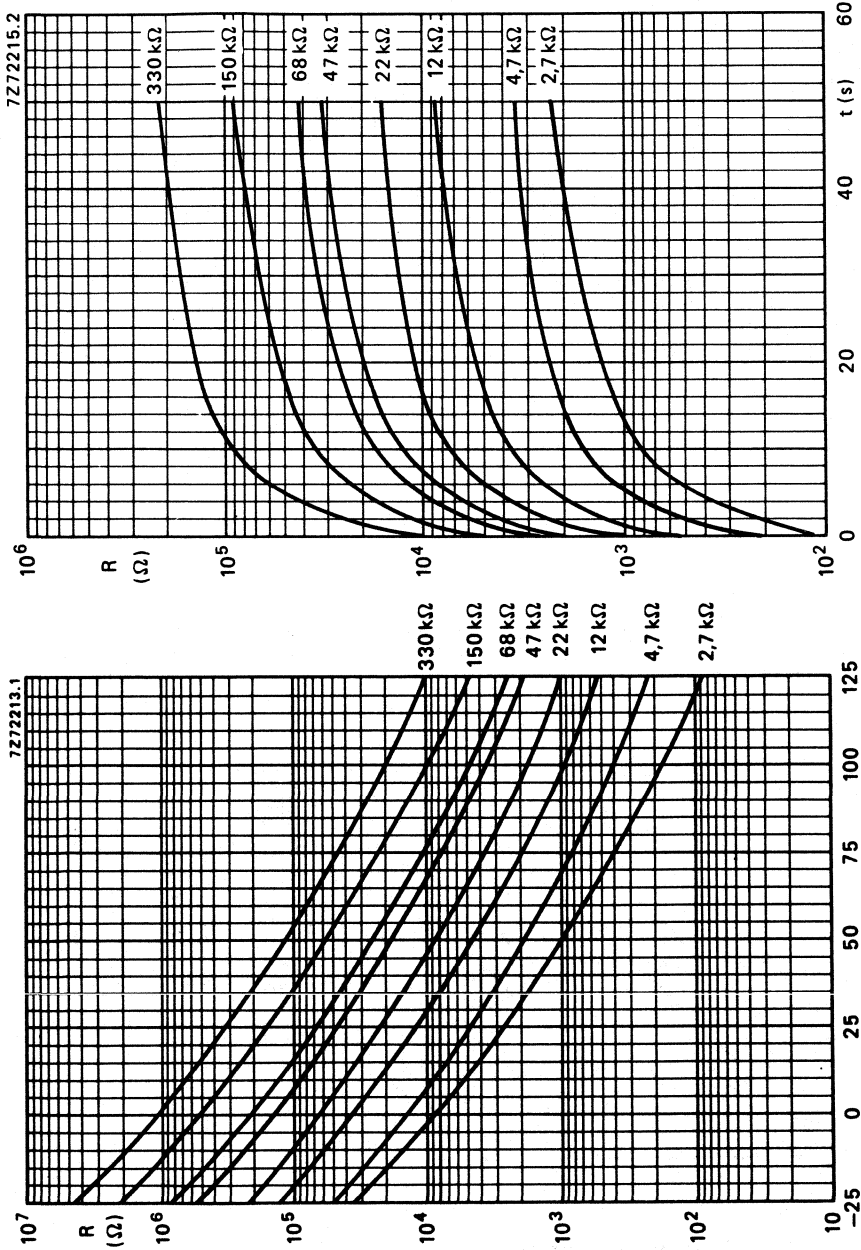

Fig. 4 Typical resistance/time (cooling) characteristic.  
 $T_{\text{amb}} = +25^{\circ}\text{C}$ , still air;  $T_{\text{start}} = +125^{\circ}\text{C}$ .

Fig. 3 Typical resistance/temperature characteristic.

## NTC THERMISTORS

two-point sensors

### APPLICATION

For temperature measurement between 0 and 30 °C.

### DESCRIPTION

The thermistor has a negative temperature coefficient. It consists of a disc with two tinned copper wires. It is grey lacquered and colour coded, but not insulated.

### MECHANICAL DATA

#### Outlines

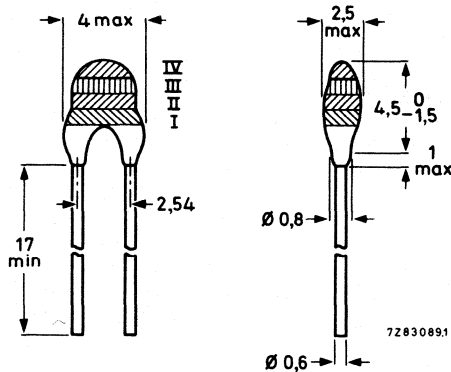

Fig. 1.

#### Marking

The thermistors are marked with colour bands, see table for colour code.

#### Mass

0,14 g approximately

#### Resistant to cleaning solvents

### ELECTRICAL DATA

Unless otherwise specified, measured according to IEC publication 539.

Maximum dissipation at  $T_{amb} = + 55 \text{ °C}^*$

0,25 W

Dissipation factor\*

7,5 mW/K approx.

Thermal time constant\*

19 s approx.

Heat capacity\*

0,135 J/K approx.

Operating temperature range

at zero power

-25 to + 125 °C

at maximum power

0 to + 55 °C

\* Measured in the measuring set described in the French standard NF C93-271, and clamped at 10 mm from the body.

catalogue number	nominal resistance value $\Omega$		colour code*		
	$5 \pm 1 \text{ }^\circ\text{C}$	$25 \pm 1 \text{ }^\circ\text{C}$	I	II	III
472	10 900	4 700	yellow	violet	red
103	23 000	10 000	brown	black	orange
223	52 000	22 000	red	red	orange
473	114 000	47 000	yellow	violet	orange
104	250 000	100 000	brown	black	yellow
224	567 000	220 000	red	red	yellow

\* Band IV is not used.

The nominal resistance value should be reached between 4 and 6  $^\circ\text{C}$  and also between 24 and 26  $^\circ\text{C}$ .

→ **PACKAGING**

500 thermistors in a cardboard box.





## NTC THERMISTORS

moulded

### QUICK REFERENCE DATA

	2322 640 90004	2322 640 98004
Resistance value at		
+ 25 °C	12 ± 7%	12 ± 7% kΩ
+ 100 °C	950 ± 5%	950 ± 5% Ω
B <sub>25/85</sub> -value	3750	3750 K
Maximum dissipation	0,25	0,25 W
Dissipation factor	7	9,5 mW/K
when mounted on a heat-sink	19	27 mW/K
Thermal time constant	19	33 s
when mounted on a heat-sink	10	5 s
Operating temperature range		
at zero power	-10 to +125	-10 to +125 °C
at maximum power	0 to +55	0 to +55 °C

### APPLICATION

For temperature control.

### DESCRIPTION

Moulded disc thermistor with negative temperature coefficient and with two solid tinned copper wires. The body colour is dark grey.

The thermistor 2322 640 98004 is provided with a metal strip for mounting.

### MECHANICAL DATA

#### Outlines

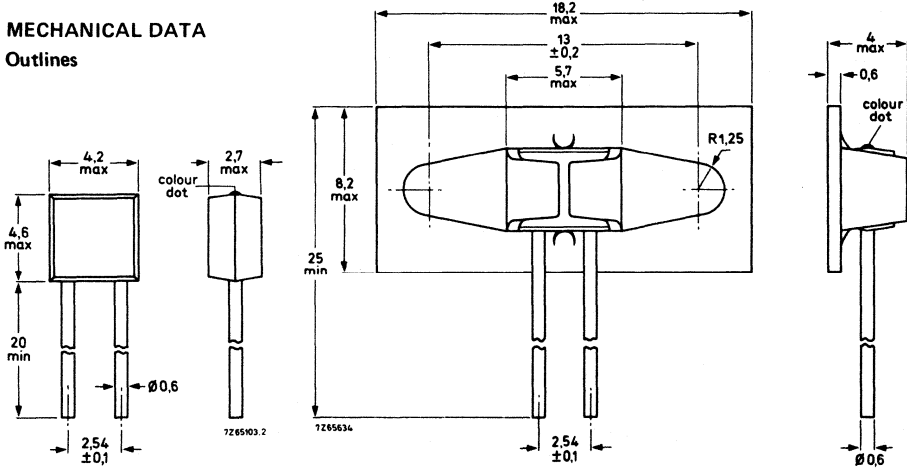

type 2322 640 90004

type 2322 640 98004  
with metal strip for mounting

2322 640 90004  
2322 640 98004

#### Marking

The thermistors have a grey dot.

#### Mass

Type 2322 640 90004

0,3 g approx.

Type 2322 640 98004

0,5 g approx.

#### Mounting

Type 2322 640 90004

in any position by soldering

Type 2322 640 98004

by means of the mounting strip

#### Robustness of terminations

Tensile strength

10 N

Bending

5 N

#### Soldering

Solderability

max. 240 °C, max. 4 s

Resistance to heat

max. 265 °C, max. 11 s

#### Impact

Free fall

1 m

#### Inflammability

Uninflammable – CCTU-01-01A specification, test 22.

#### PACKAGING

Type 2322 640 90004: 500 thermistors in a cardboard box.

Type 2322 640 98004: 400 thermistors in a cardboard box.



**ELECTRICAL DATA**

Unless otherwise specified, measured according to IEC publication 539.

All values in the table without further indication are approximate values.

	2322 640 90004	2322 640 98004	
Resistance at			
+ 25 °C	12 ± 7%	12 ± 7%	kΩ
+ 100 °C	950 ± 5%	950 ± 5%	Ω
B <sub>25/85</sub> -value	3750	3750	K
Temperature coefficient	-4,2	-4,2	%/K
Maximum dissipation	0,25	0,25	W
Dissipation factor	7	9,5	mW/K
when mounted on a heatsink *	19	27	mW/K
Thermal time constant	19	33	s
when mounted on a heatsink *	10	5	s
Heat capacity of ceramic	0,028	0,028	J/K
of complete component	0,13	0,3	J/K
Response time **	3	3	s
Operating temperature range			
at zero power	-10 to + 125	-10 to + 125	°C
at maximum power	0 to + 55	0 to + 55	°C
Dielectric withstanding voltage (r.m.s.) between terminals and coating/strip	min. 350	min. 350	V
Insulation resistance between terminals and coating/strip at 100 V (d.c.)	min. 100	min. 100	MΩ



\* Measurements made in still air with the thermistor mounted on a heatsink of 100 cm<sup>2</sup>, thickness 1,5 mm, and connected between phosphor-bronze wires (ϕ1,3 mm).

\*\* The thermistor being transferred from ambient air of + 25 °C to a silicone oil (MS200/50) bath of + 85 °C.

2322 640 90004  
2322 640 98004

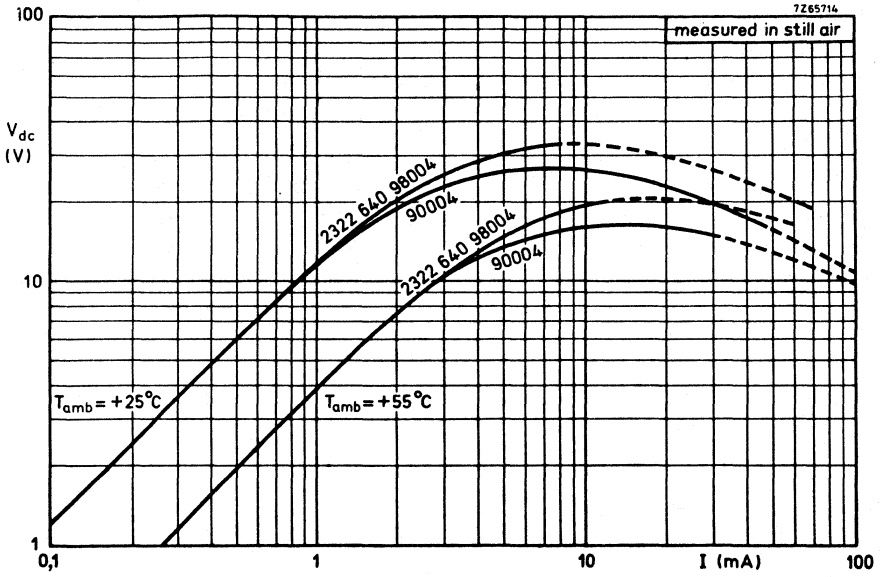

Fig. 2 Typical voltage/current characteristics.

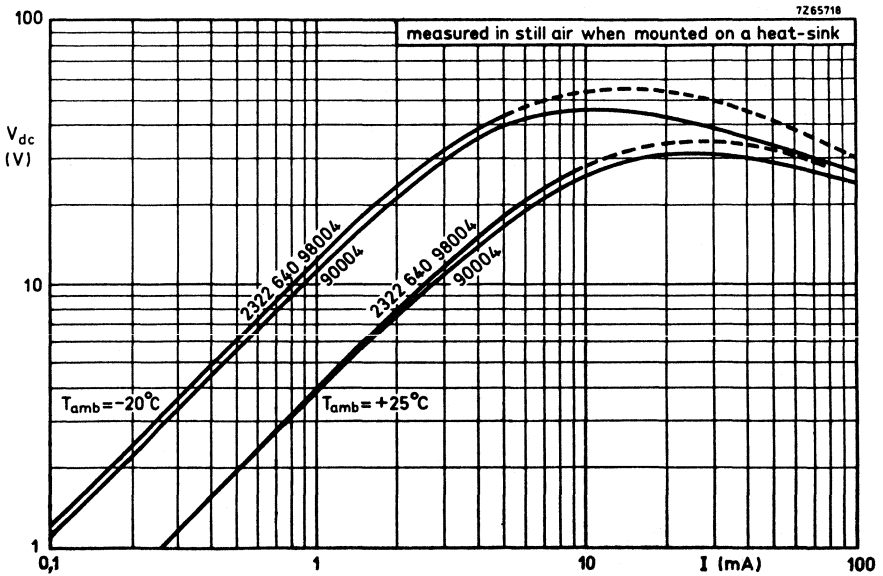

Fig. 3 Typical voltage/current characteristics.

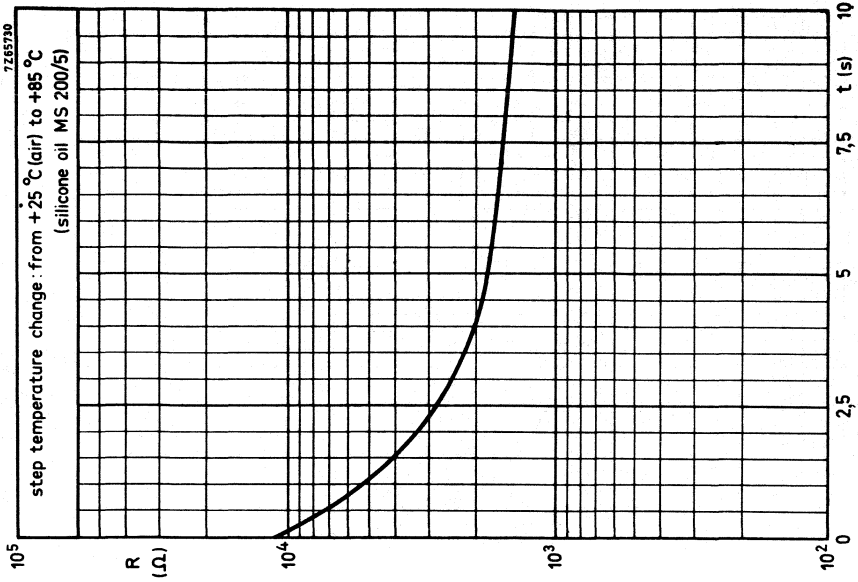

Fig. 5 Typical resistance/response time characteristics.

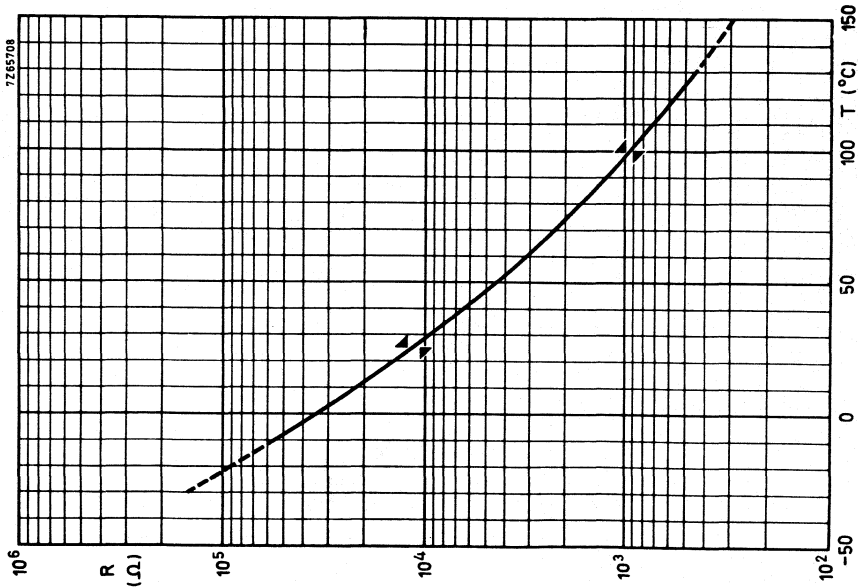

Fig. 4 Typical resistance/temperature characteristics.



2322 640 90004  
2322 640 98004

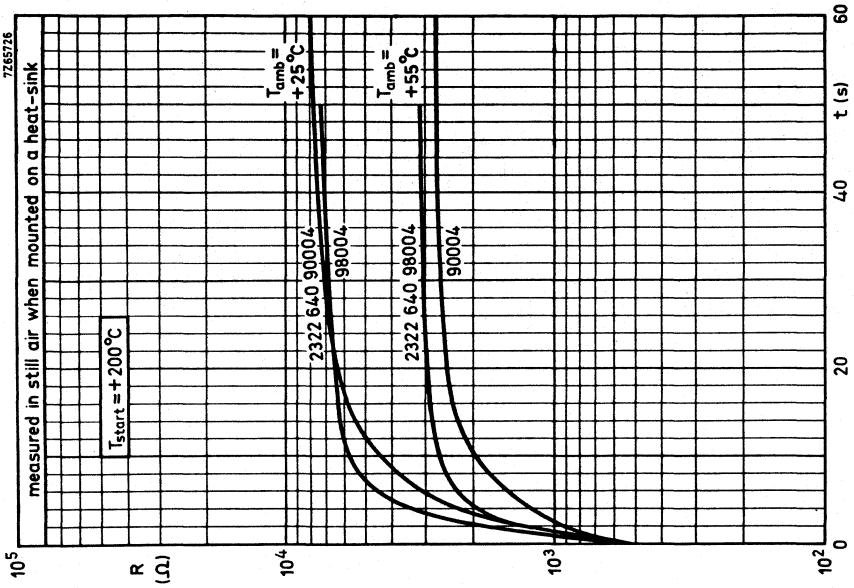

Fig. 7 Typical resistance/time (cooling) characteristics.

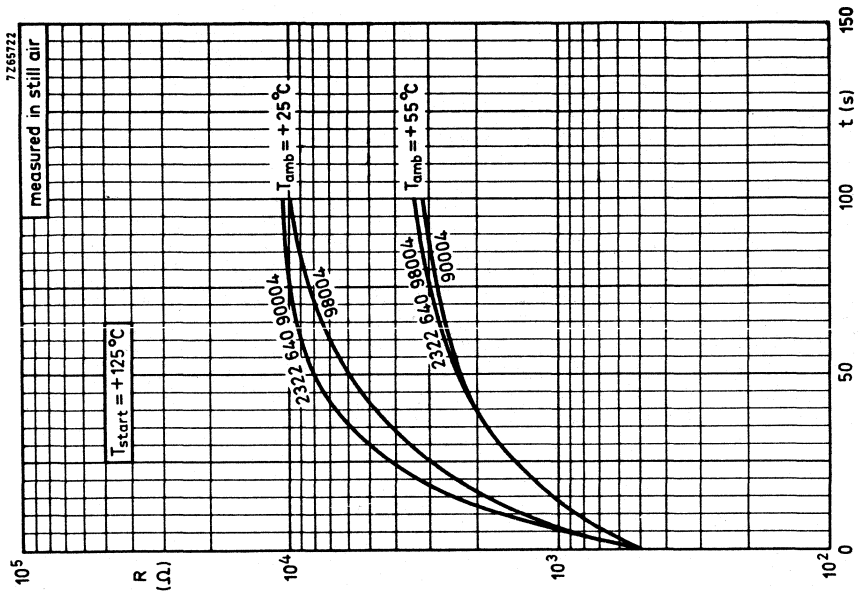

Fig. 6 Typical resistance/time (cooling) characteristics.

## NTC THERMISTORS

moulded

### QUICK REFERENCE DATA

	2322 640 90005	2322 640 98005
Resistance at + 100 °C	16,7 ± 7%	16,7 ± 7% kΩ
+ 200 °C	1120 ± 7%	1120 ± 7% Ω
B <sub>25/85</sub> -value	4300	4300 K
Maximum dissipation	0,25	0,25 W
Dissipation factor	7	9,5 mW/K
when mounted on a heat-sink	17,5	20,5 mW/K
Thermal time constant	19	33 s
when mounted on a heat-sink	12	8,5 s
Operating temperature range at zero power	-25 to +200	-25 to +200 °C
at maximum power	0 to +55	0 to +55 °C

### APPLICATION

For high temperature control.

### DESCRIPTION

Moulded disc thermistor with negative temperature control and with two solid tinned copper wires. The body colour is dark grey.

The thermistor 2322 640 98005 is provided with a metal strip for mounting.

### MECHANICAL DATA

#### Outlines

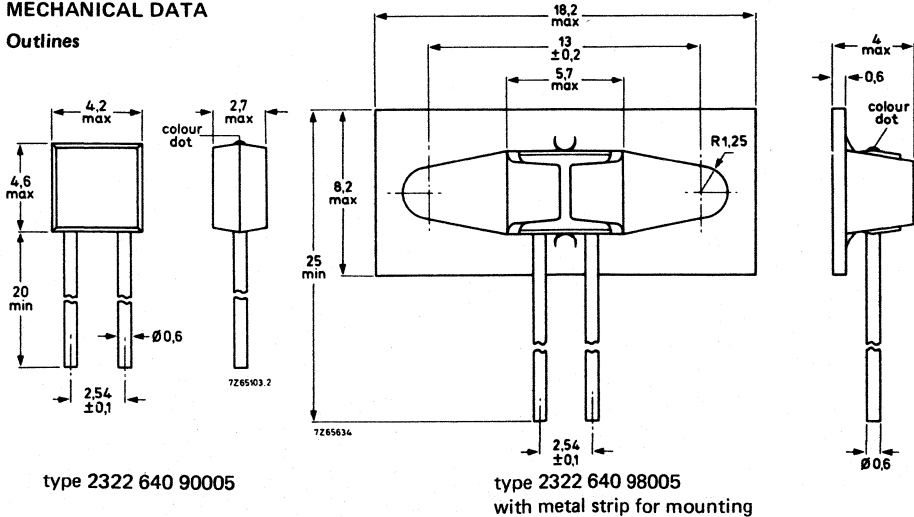

2322 640 90005  
2322 640 98005

#### Marking

→ The thermistors have a blue dot.

#### Mass

Type 2322 640 90005

0,3 g approx.

Type 2322 640 98005

0,5 g approx.

#### Mounting

Type 2322 640 90005

in any position by soldering

Type 2322 640 98005

by means of the mounting strip

#### Robustness of terminations

Tensile strength

10 N

Bending

5 N

#### Soldering

Solderability

max. 240 °C, max. 4 s

Resistance to heat

max. 265 °C, max. 11 s

#### Impact

Free fall

1 m

#### Inflammability

Uninflammable – CCTU-01-01A specification, test 22.

#### PACKAGING

Type 2322 640 90005: 500 thermistors in a cardboard box.

Type 2322 640 98005: 400 thermistors in a cardboard box.





**ELECTRICAL DATA**

Unless otherwise specified, measuring according to IEC publication 539.

All values in the table without further indication are approximate values.

	2322 640 90005	2322 640 98005	
Resistance at			
+ 100 °C	16,7 ± 7%	16,7 ± 7%	kΩ
+ 200 °C	1120 ± 7%	1120 ± 7%	Ω
+ 25 °C	310	310	kΩ
B <sub>25/85</sub> -value	4300	4300	K
Temperature coefficient	-4,85	-4,85	%/K
Maximum dissipation	0,25	0,25	W
Dissipation factor	7	9,5	mW/K
when mounted on a heatsink *	17,5	20,5	mW/K
Thermal time constant	19	33	s
when mounted on a heatsink *	12	8,5	s
Heat capacity of ceramic	0,028	0,028	J/K
of complete component	0,13	0,31	J/K
Response time **	3	3	s
Operating temperature range			
at zero power	-25 to +200	-25 to +200	°C
at maximum power	0 to +55	0 to +55	°C
Dielectric withstanding voltage (r.m.s.)			
between terminals and coating	min. 350	min. 350	V
Insulation resistance between terminals			
and coating at 100 V (d.c.)	min. 100	min. 100	MΩ



\* Measurements made in still air with the thermistor mounted on a heatsink of 100 cm<sup>2</sup>, thickness 1,5 mm, connected between phosphor-bronze wires (ϕ 1,3 mm).

\*\* The thermistor being transferred from ambient air of +25 °C to a silicone oil (MS200/50) bath of +85 °C.

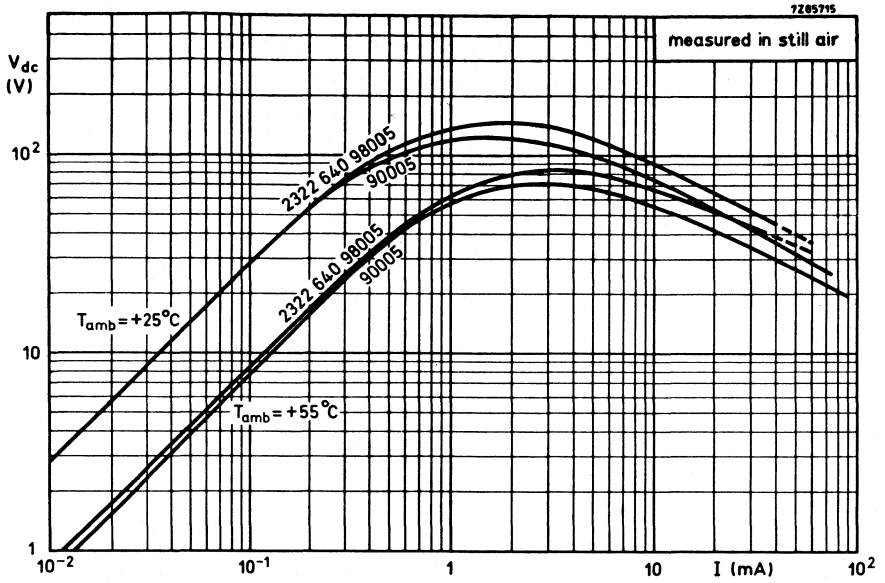

Fig. 2 Typical voltage/current characteristics.

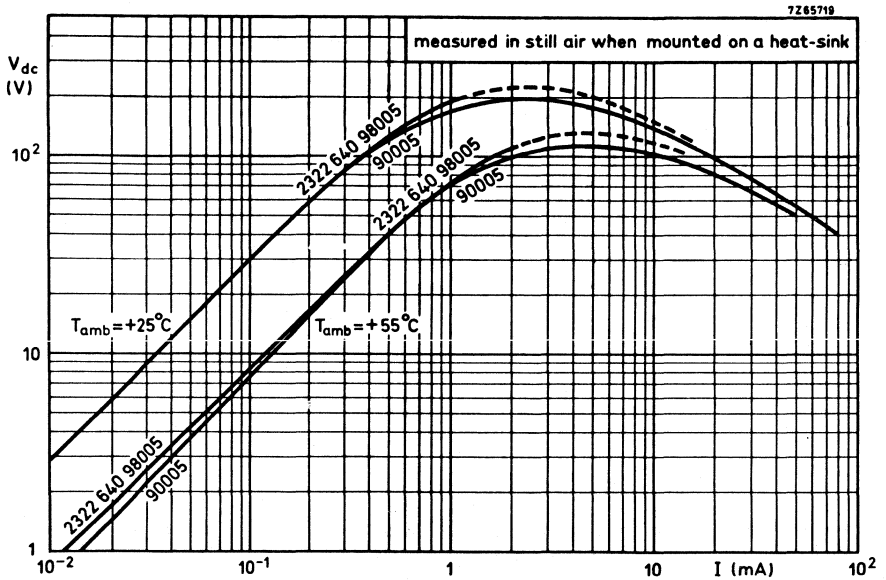

Fig. 3 Typical voltage/current characteristics.

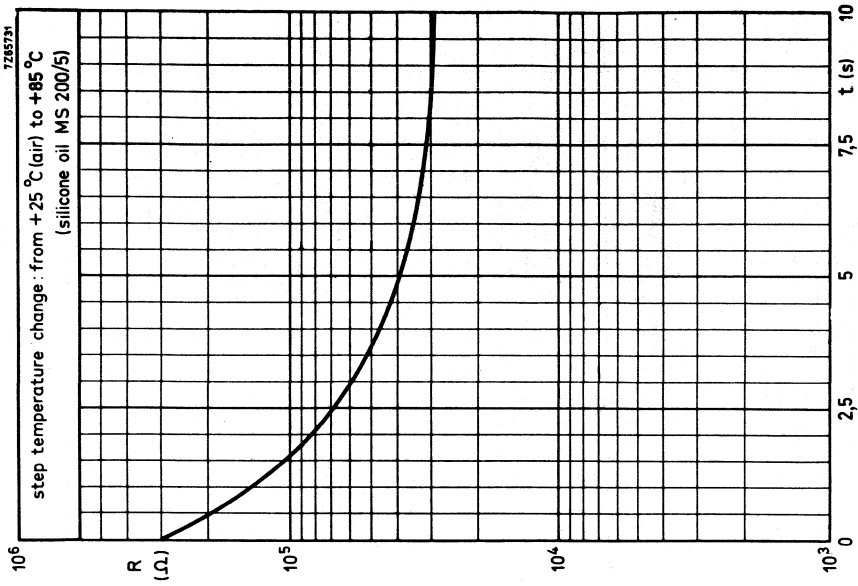

Fig. 5 Typical resistance/response time characteristics.

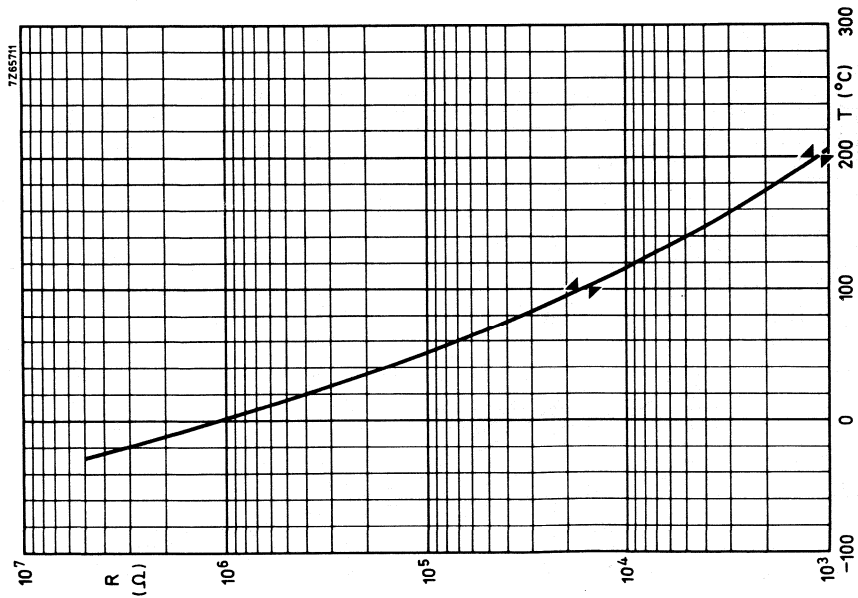

Fig. 4 Typical resistance/temperature characteristics.



2322 640 90005  
 2322 640 98005

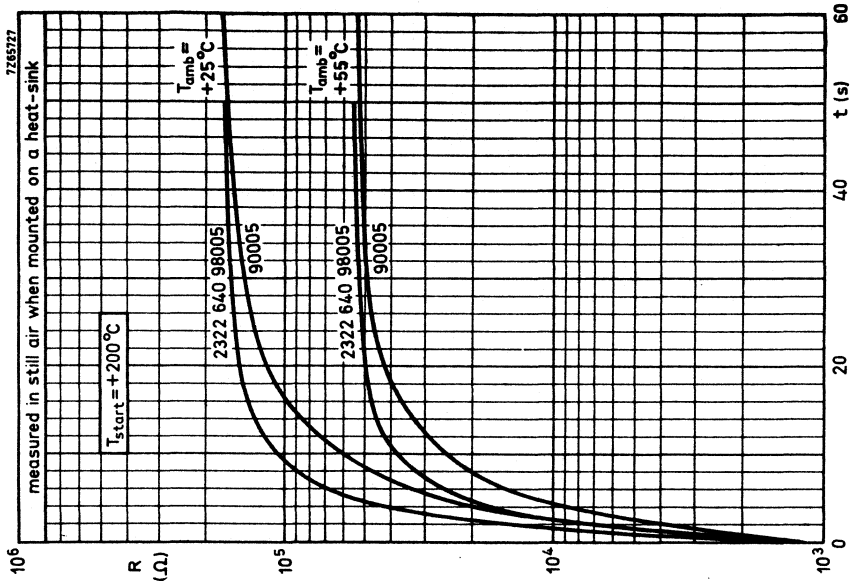

Fig. 7 Typical resistance/time (cooling) characteristics.

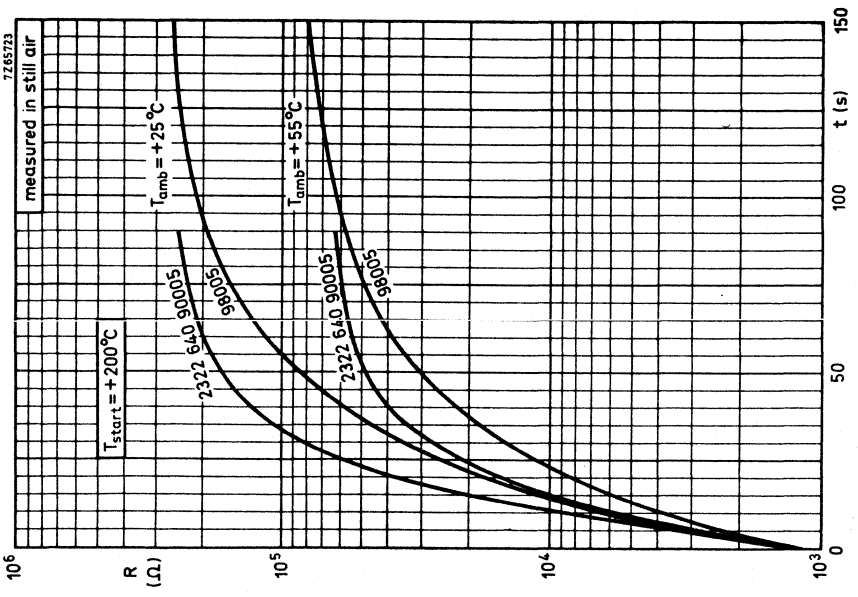

Fig. 6 Typical resistance/time (cooling) characteristics.

## NTC THERMISTORS

### QUICK REFERENCE DATA

	2322 640 90007	2322 640 90021
Resistance value		
at +25 °C	12 kΩ ± 7%	12 kΩ ± 5,5%
at +90 °C	1,3 kΩ ± 5%	1285 Ω ± 3,5%
B <sub>25/85</sub> -value	3700 K	3720 K
Maximum dissipation	0,25 W	
Dissipation factor		
in still air	7,5 mW/K	
in still water	18 mW/K	
Thermal time constant in still air	285 s	
Operating temperature range		
at zero power, continuously	-25 to +110 °C	
for max. 24 h	to +130 °C	
at maximum power	0 to +55 °C	

### APPLICATION

As a temperature sensor for water temperature control in washing machines, dish washers, etc.

### DESCRIPTION

Disc thermistor with negative temperature coefficient, mounted in a capsule of stainless steel, with two tinned brass spade connectors.

### MECHANICAL DATA

#### Outlines

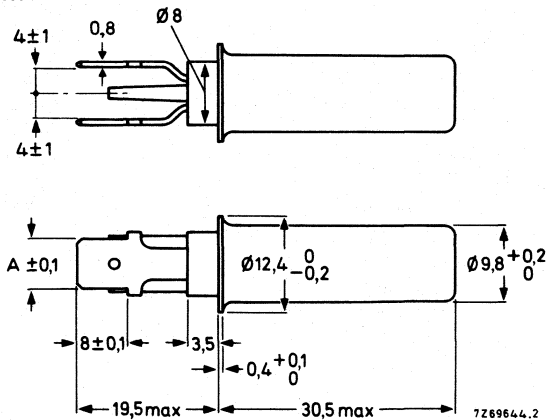

Fig. 1.

A = 6,3 mm for thermistor 2322 640 90007  
A = 2,8 mm for thermistor 2322 640 90021

2322 640 90007  
2322 640 90021

**Marking**

2322 640 90007  
2322 640 90021

brown dot between connectors  
orange dot between connectors

**Mass**

8 g approximately

**Mounting**

In any position

**Robustness of terminations**

**Tensile strength**

50 N

**Impact**

**Free fall**

1 m

**Inflammability**

Uninflammable

**ELECTRICAL DATA**

Unless otherwise specified, measuring according to IEC publication 539.

Type	2322 640 90007	2322 640 90021
Resistance at + 25 °C	12 kΩ ± 7%	12 kΩ ± 5,5%
+ 90 °C	1,3 kΩ ± 5%	1285 Ω ± 3,5%
B25/85-value	3700 K	3720 K
Temperature coefficient	-4,2%/K	
Maximum dissipation	0,25 W	
Dissipation factor in still air	7,5 mW/K	
in still water	18 mW/K	
Thermal time constant in still air	285 s	
Response time*	11 s	
Temperature gradient**	0,02 K/K	
Operating temperature range at zero power continuously max. 24 h at maximum power	min. -25 °C max. + 110 °C max. + 130 °C 0 to + 55 °C	
Dielectric withstanding voltage (r.m.s.) between terminals and capsule for 10 s 60 s	min. 1650 V min. 1500 V	
Insulation resistance between terminals and capsule at 100 V (d.c.)	min. 100 MΩ	

**PACKAGING**

50 thermistors in a cardboard in box.

\* The thermistor being transferred from ambient air of +25 °C to water of +100 °C.

\*\* The temperature gradient is the difference between the liquid (water) temperature and the temperature measured by the sensor per degree difference between liquid and connector temperatures. This difference is caused by the heat conduction through the connectors. Measuring circuit is shown in

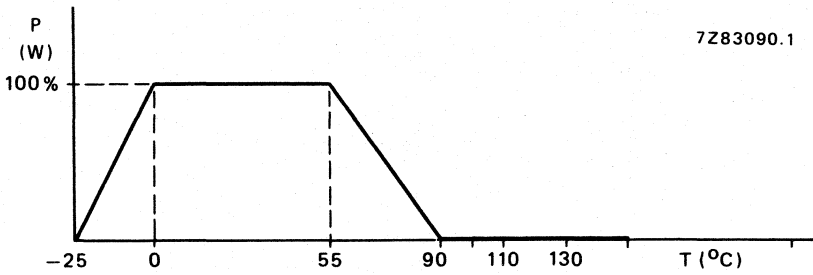
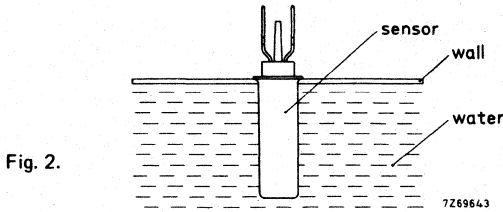

Fig. 3 Power derating with ambient temperature.

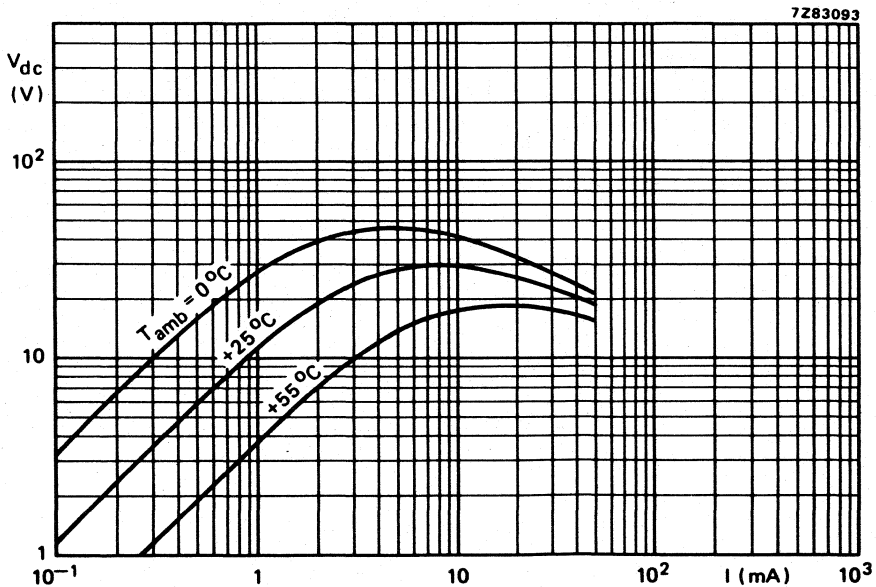

Fig. 4 Typical voltage/current characteristic measured in still air.

2322 640 90007  
2322 640 90021

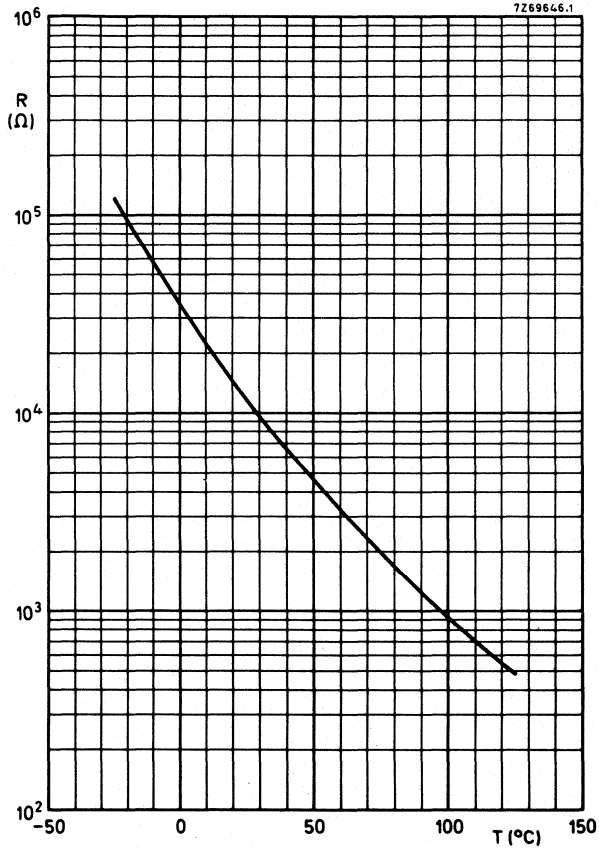

Fig. 5 Typical resistance/temperature characteristic.



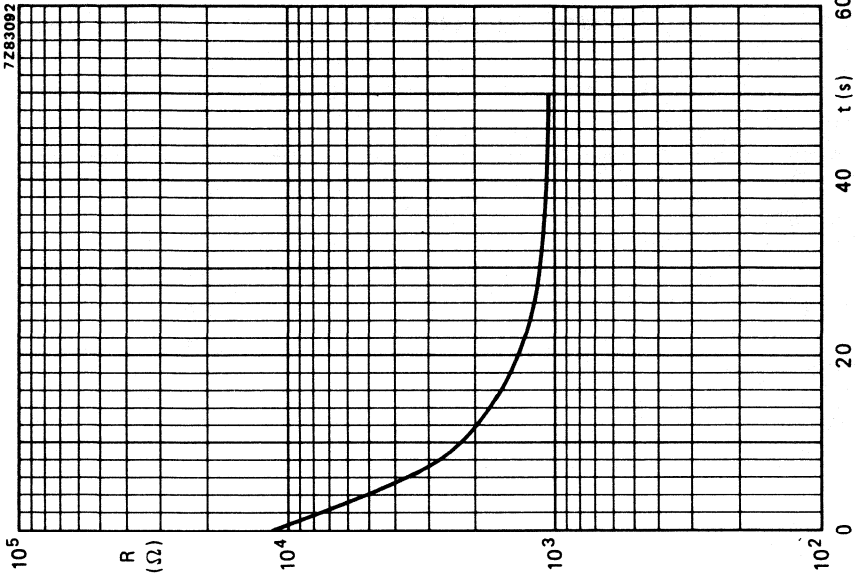

Fig. 7 Typical resistance/response time characteristic. Temperature step from still air of +25 °C to still water of +100 °C.

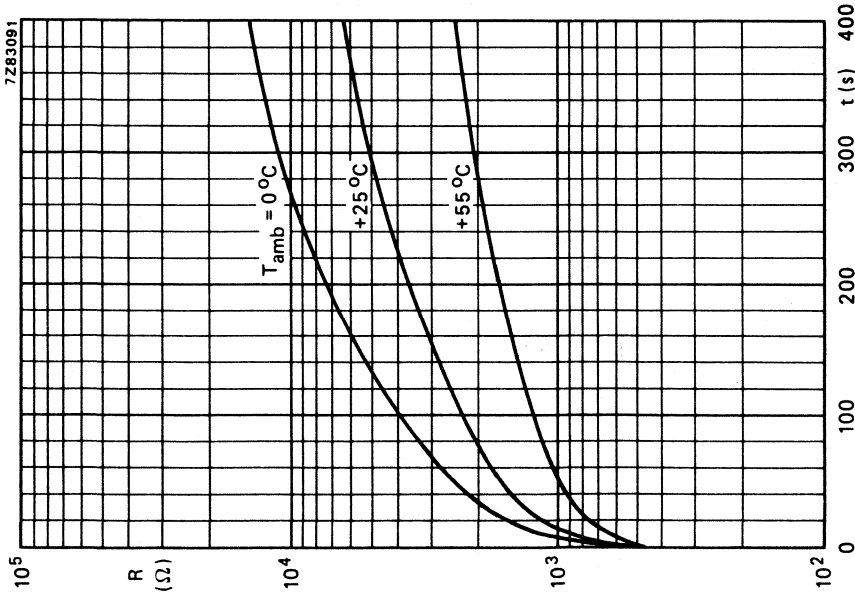

Fig. 6 Typical resistance/time (cooling) characteristics measured in still air, T<sub>start</sub> = +125 °C.



## NTC THERMISTOR

### QUICK REFERENCE DATA

Resistance value	
at $-30 \pm 1,5 \text{ }^\circ\text{C}$	50 k $\Omega$
at $-20 \pm 1,5 \text{ }^\circ\text{C}$	27 k $\Omega$
at $-10 \pm 1,5 \text{ }^\circ\text{C}$	15 k $\Omega$
B <sub>25/85</sub> -value	4000 K
Maximum dissipation	0,25 W
Dissipation factor	7,5 mW/K
Thermal time constant	19 s
Operating temperature range	
at zero power	$-55 \text{ to } +85 \text{ }^\circ\text{C}$
at maximum power	$-55 \text{ to } +55 \text{ }^\circ\text{C}$

### APPLICATION

For temperature control in deep-freezers.

### DESCRIPTION

The thermistor has a negative temperature coefficient. It consists of a disc with two solid tinned copper wires. It is grey lacquered and colour coded, but not insulated.

### MECHANICAL DATA

#### Outlines

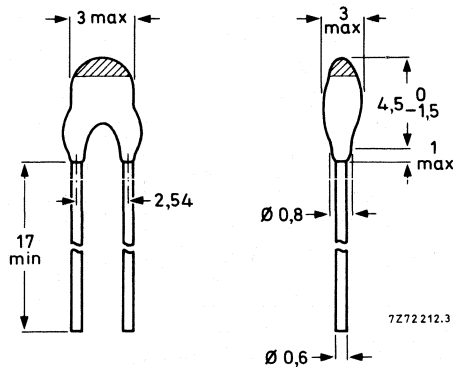

Fig.1.

**Marking**

The thermistor is marked with a brown band on top of the body.

**Mass**

0,14 g approximately.

**Mounting**

In any position by soldering.

**Robustness of terminations**

Tensile strength      10 N  
Bending                      5 N

**Soldering**

Solderability              max. 240 °C, max. 4 s  
Resistance to heat        max. 265 °C, max. 11 s

**Impact**

Free fall                      1 m

**Unflammable**

Resistant to cleaning solvents

**PACKAGING**

500 thermistors in a cardboard box.

**ELECTRICAL DATA**

Unless otherwise specified, measured according to IEC publication 539.

Resistance value	
at $-30 \pm 1,5$ °C	50 k $\Omega$
at $-20 \pm 1,5$ °C	27 k $\Omega$
at $-10 \pm 1,5$ °C	15 k $\Omega$
B <sub>25/85</sub> -value	4000 K approx.
Temperature coefficient at +25 °C	-4,5 %/K approx.
Maximum dissipation at T <sub>amb</sub> = +55 °C	0,25 W
Dissipation factor	7,5 mW/K approx.
Thermal time constant	19 s approx.
Heat capacity	0,135 J/K approx.
Operating temperature range	
at zero power	-55 to +85 °C
at maximum power	-55 to +55 °C

For typical resistance/temperature characteristic, see page 173

2322 640 90013  
2322 640 98013

## NTC THERMISTORS

moulded

### QUICK REFERENCE DATA

	2322 640 90013	2322 640 98013	
Resistance value			
at $-30 \pm 1,5$ °C	50	50	kΩ
at $-20 \pm 1,5$ °C	27	27	kΩ
at $-10 \pm 1,5$ °C	15	15	kΩ
B <sub>25/85</sub> -value	4000	4000	K
Maximum dissipation	0,25	0,25	W
Dissipation factor	6,7	9	mW/K
when mounted on a heatsink	16	21	mW/K
Thermal time constant	17	32	s
when mounted on a heatsink	6	3	s
Operating temperature range			
at zero power	$-55$ to $+85$	$-55$ to $+85$	°C
at maximum power	$-55$ to $+55$	$-55$ to $+55$	°C

### APPLICATION

For temperature control in deep-freezers.

### DESCRIPTION

Dark grey moulded disc thermistor with negative temperature coefficient and with two solid tinned copper wires. The thermistor 2322 640 98013 has a metal strip for mounting.

### MECHANICAL DATA

#### Outlines

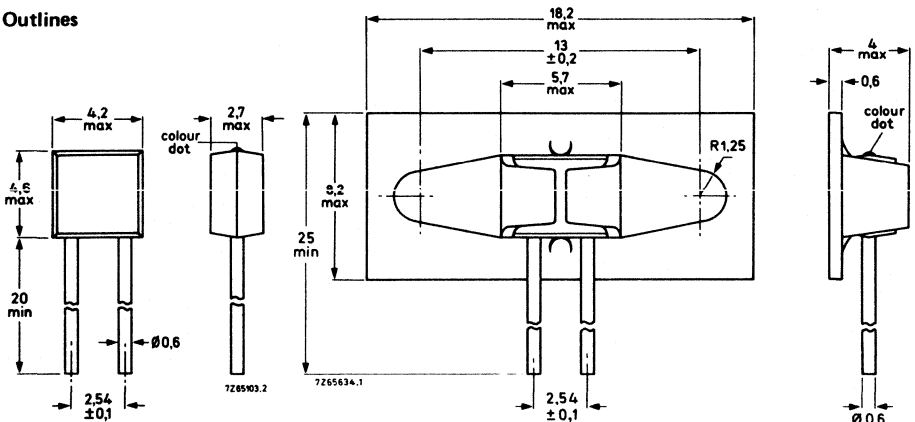

Fig. 1 Type 2322 640 90013.

Fig. 2 Type 2322 640 98013 with metal strip for mounting.

**Marking**

The thermistors have a brown dot.

**Mass**

Type 2322 640 90013

0,3 g approx.

Type 2322 640 98013

0,5 g approx.

**Mounting**

Type 2322 640 90013

in any position by soldering

Type 2322 640 98013

by means of the mounting strip

**Robustness of terminations**

Tensile strength

10 N

Bending

5 N

**Soldering**

Solderability

max. 240 °C, max. 4 s

Resistance to heat

max. 265 °C, max. 11 s,

solder bath 5 mm from body

**Impact**

Free fall

1 m

**Inflammability**

Uninflammable



**PACKAGING**

Type 2322 640 90013: 500 thermistors in a cardboard box.

Type 2322 640 98013: 400 thermistors in a cardboard box.

**ELECTRICAL DATA**

Unless otherwise specified, measured according to IEC publication 539.

All values in the table without further indication are approximate values.

	2322 640 90013	2322 640 98013	
Resistance value			
at $-30 \pm 1,5$ °C	50	50	k $\Omega$
at $-20 \pm 1,5$ °C	27	27	k $\Omega$
at $-10 \pm 1,5$ °C	15	15	k $\Omega$
B <sub>25/85</sub> -value	4000	4000	K
Temperature coefficient	-4,5	-4,5	%/K
Maximum dissipation at T <sub>amb</sub> = +55 °C	0,25	0,25	W
Dissipation factor	6,7	9	mW/K
when mounted on a heatsink *	16	21	mW/K
Thermal time constant	17	32	s
when mounted on a heatsink *	6	3	s
Heat capacity			
of ceramic	0,009	0,009	J/K
of complete component	0,11	0,29	J/K
Response time **	1,3		s
Operating temperature range			
at zero power	-55 to +85	-55 to +85	°C
at maximum power	-55 to +55	-55 to +55	°C
Dielectric withstanding voltage (r.m.s.) between terminals and coating	min. 350	min. 350	V
Insulation resistance between terminals and coating at 100 V (d.c.)	min. 100	min. 100	M $\Omega$

\* The thermistor mounted on a heatsink of 100 cm<sup>2</sup>, thickness 1,5 mm.

\*\* From air of +25 °C to silicone oil (MS 200/5) of -20 °C.

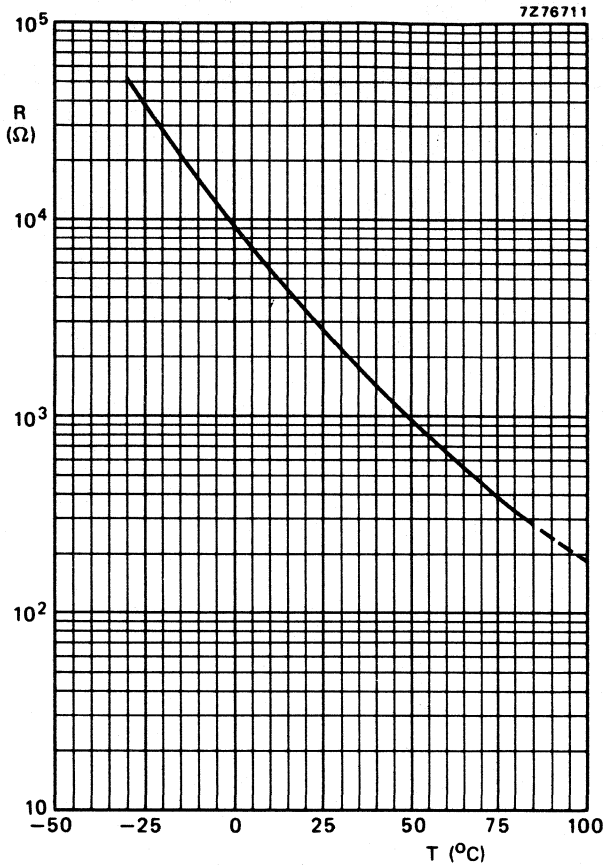

Fig. 3 Typical resistance/temperature characteristic.

## NTC THERMISTOR

## QUICK REFERENCE DATA

Resistance value	
at $-10 \pm 1,5$ °C	15 k $\Omega$
at $+25 \pm 1,5$ °C	2,7 k $\Omega$
B <sub>25/85</sub> -value	4000 K
Maximum dissipation	0,25 W
Dissipation factor	7,5 mW/K
Thermal time constant	19 s
Operating temperature range	
at zero power	-55 to +85 °C
at maximum power	-55 to +55 °C

## APPLICATION

For room temperature control.

## DESCRIPTION

The thermistor has a negative temperature coefficient. It consists of a disc with two solid tinned copper wires. It is grey lacquered and colour coded, but not insulated.

## MECHANICAL DATA

## Outlines

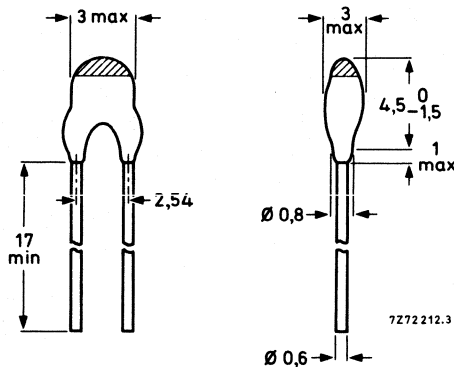

Fig.1.



**Marking**

The thermistor is marked with a red band on top of the body.

**Mass**

0,14 g approximately.

**Mounting**

In any position by soldering.

**Robustness of terminations**

Tensile strength	10 N
Bending	5 N

**Soldering**

Solderability	max. 240 °C, max. 4 s
Resistance to heat	max. 265 °C, max. 11 s

**Impact**

Free fall	1 m
-----------	-----

**Uninflammable**

Resistant to cleaning solvents

**PACKAGING**

500 thermistors in a cardboard box.

**ELECTRICAL DATA**

Unless otherwise specified, measured according to IEC publication 539.

Resistance value	
at $-10 \pm 1,5$ °C	15 k $\Omega$
at $+25 \pm 1,5$ °C	2,7 k $\Omega$
B <sub>25/85</sub> -value	≈ 4000 K
Temperature coefficient at +25 °C	≈ -4,5 %/K
Maximum dissipation at T <sub>amb</sub> = +55 °C	0,25 W
Dissipation factor	≈ 7,5 mW/K
Thermal time constant	≈ 19 s approx.
Heat capacity	≈ 0,135 J/K
Operating temperature range	
at zero power	-55 to +85 °C
at maximum power	-55 to +55 °C



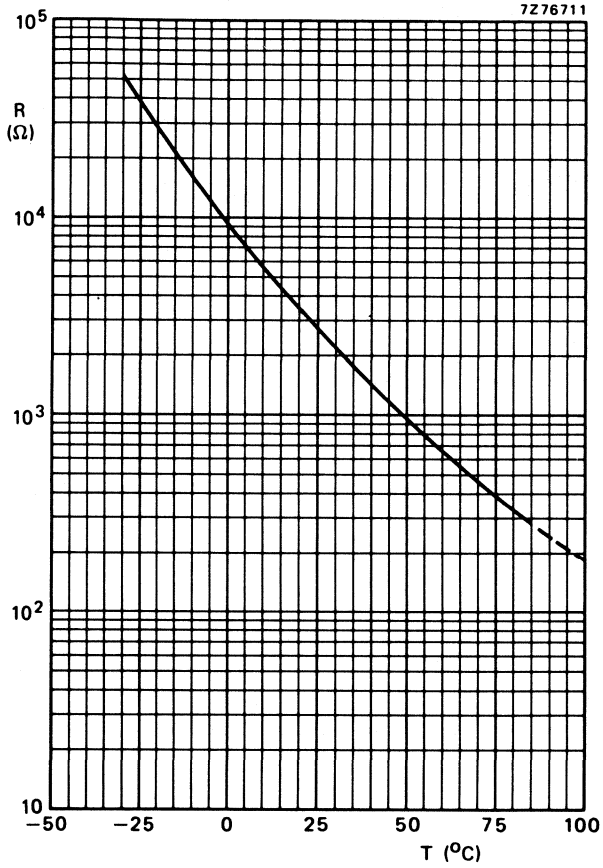

Fig.2 Typical resistance/temperature characteristic.

## NTC THERMISTORS

moulded

### QUICK REFERENCE DATA

	2322 640 90015	2322 640 98015	
Resistance value			
at $-10 \pm 1,5 \text{ }^\circ\text{C}$	15	15	k $\Omega$
at $+25 \pm 1,5 \text{ }^\circ\text{C}$	2,7	2,7	k $\Omega$
B <sub>25/85</sub> -value	4000	4000	K
Maximum dissipation	0,25	0,25	W
Dissipation factor	6,7	9	mW/K
when mounted on a heatsink	16	21	mW/K
Thermal time constant	17	32	s
when mounted on a heatsink	6	3	s
Operating temperature range			
at zero power	-55 to +85	-55 to +85	$^\circ\text{C}$
at maximum power	-55 to +55	-55 to +55	$^\circ\text{C}$

### APPLICATION

For room temperature control.

### DESCRIPTION

Moulded disc thermistor with negative temperature coefficient and with two solid tinned copper wires.  
Body dark grey.  
The thermistor 2322 640 98015 has a metal strip for mounting.

### MECHANICAL DATA

#### Outlines

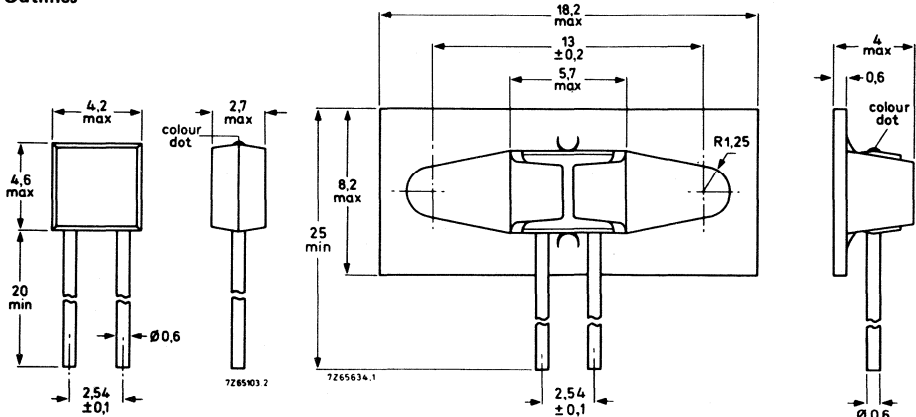

Fig.1 Type 2322 640 90015.

Fig.2 Type 2322 640 98015 with metal strip for mounting.

2322 640 90015  
2322 640 98015

#### Marking

The thermistors have a red dot.

#### Mass

Type 2322 640 90015	0,3 g approx.
Type 2322 640 98015	0,5 g approx.

#### Mounting

Type 2322 640 90015	in any position by soldering
Type 2322 640 98015	by means of the mounting strip

#### Robustness of terminations

Tensile strength	10 N
Bending	5 N

#### Soldering

Solderability	max. 240 °C, max. 4 s
Resistance to heat	max. 265 °C, max. 11 s, solder bath 5 mm from body

#### Impact

Free fall	1 m
-----------	-----

#### Inflammability

Uninflammable

#### PACKAGING

Type 2322 640 90015: 500 thermistors in a cardboard box.  
Type 2322 640 98015: 400 thermistors in a cardboard box.



**ELECTRICAL DATA**

Unless otherwise specified, measured according to IEC publication 539.

All values in the table without further indication are approximate values.

	2322 640 90015	2322 640 98015	
Resistance value			
at $-10 \pm 1,5$ °C	15	15	k $\Omega$
at $+25 \pm 1,5$ °C	2,7	2,7	k $\Omega$
B <sub>25/85</sub> -value	4000	4000	K
Temperature coefficient	-4,5	-4,5	%/K
Maximum dissipation at T <sub>amb</sub> = +55 °C	0,25	0,25	W
Dissipation factor	6,7	9	mW/K
when mounted on a heatsink *	16	21	mW/K
Thermal time constant	17	32	s
when mounted on a heatsink *	6	3	s
Heat capacity			J/K
of ceramic	0,009	0,009	J/K
of complete component	0,11	0,29	J/K
Response time **	1,3		s
Operating temperature range			
at zero power	-55 to +85	-55 to +85	°C
at maximum power	-55 to +55	-55 to +55	°C
Dielectric withstanding voltage (r.m.s.) between terminals and coating	min. 350	min. 350	V
Insulation resistance between terminals and coating at 100 V (d.c.)	min. 100	min. 100	M $\Omega$



\* The thermistor mounted on a heatsink of 100 cm<sup>2</sup>, thickness 1,5 mm.

\*\* From air of +25 °C to silicone oil (MS 200/5) of -20 °C.

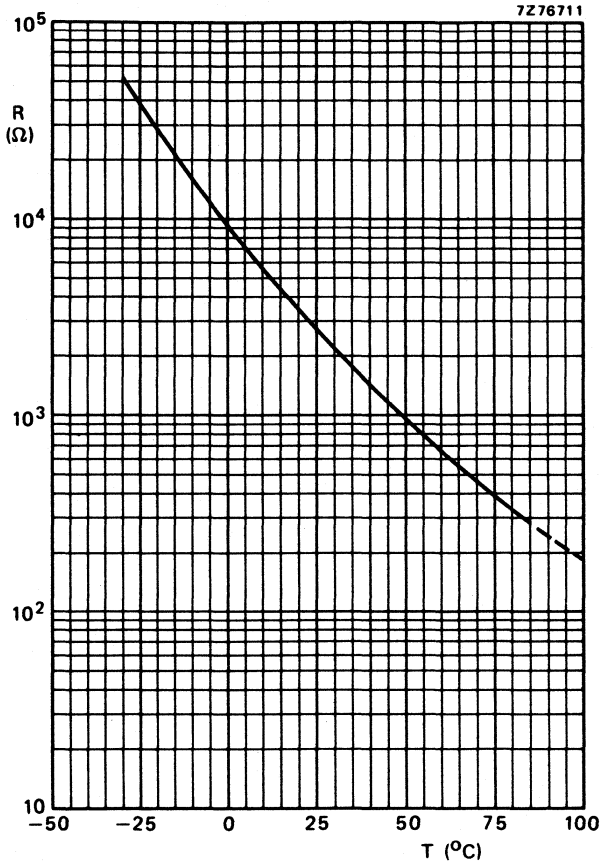

Fig.3 Typical resistance/temperature characteristic.

## NTC THERMISTOR

disc

### QUICK REFERENCE DATA

Resistance value at + 25 °C	3,3 Ω to 470 kΩ (E6 series)
B <sub>25/85</sub> value	2675 to 4650 K
Maximum dissipation	0,5 W
Dissipation factor	8,5 mW/K
Thermal time constant	≈ 17 s
Operating temperature range	
at zero power	-25 to + 125 °C
at maximum power	0 to + 55 °C

### APPLICATION

Intended for general use.

### DESCRIPTION

The thermistor has a negative temperature coefficient, it consists of a disc with two tinned copper wires. It is grey lacquered and colour coded, but not insulated.

### MECHANICAL DATA

Outlines

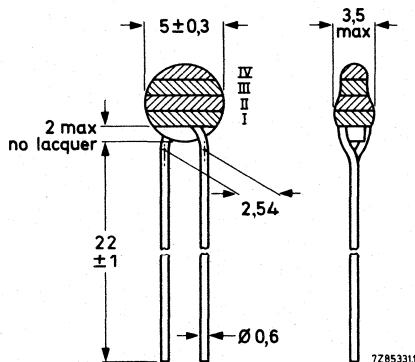

Fig. 1.

### PACKAGING

500 thermistors in a cardboard box.

**Marking**

The thermistors are marked with three or four colour bands in accordance with Fig. 1 and Table 1.

**Mass**

0,25 g approximately.

**Mounting**

In any position by soldering.

**Robustness of terminations**

Tensile strength	10 N
Bending	5 N

**Soldering**

Solderability	max. 240 °C, max. 4 s
Resistance to heat	260 ± 5 °C, 10 ± 1 s

**Impact**

Free fall	1 m
-----------	-----

**Flammability**

Not inflammable according to IEC as described by TC50 (1979), needle flame.

**Resistance to solvents**

According to IEC 68-2-45, resistant to R113 at T<sub>amb</sub>.

**ELECTRICAL DATA**

Unless otherwise specified, measured according to IEC publication 539.

Resistance at 25 °C	see Table 1
B <sub>25/85</sub> values	see Table 1
Temperature coefficient	see Table 1
Maximum dissipation*	0,5 W
Dissipation factor*	≈ 8,5 mW/K V/K
Thermal time constant*	≈ 17 s
Operating temperature range	
at zero power	-25 to + 125 °C
at maximum power, see Fig. 2	0 to + 55 °C

**7282875**

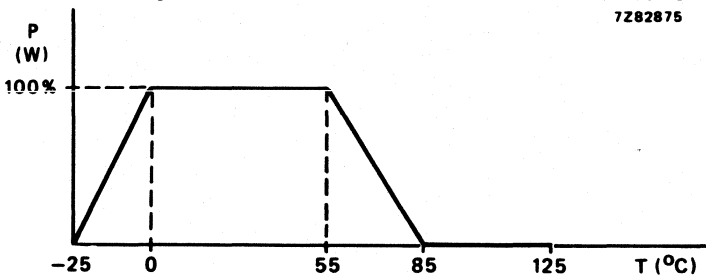

Fig. 2 Derating curve.

\* Measured in the measuring set described in the French norm NF C93-271, and clamped at 10 mm from the body.



Table 1 Catalogue number 2322 642 6....

suffix of catalogue number	R <sub>25</sub>	B <sub>25/85</sub> ± 5%	temperature coefficient	colour code (see Marking)			
	Ω	K	%/K	I	II	III	*
.338	3,3	2675	-3,0	orange	orange	gold	
.478	4,7	2750	-3,1	yellow	violet	gold	
.688	6,8	2800	-3,2	blue	grey	gold	
.109	10	2875	-3,2	brown	black	black	
.159	15	2950	-3,3	brown	green	black	
.229	22	3025	-3,4	red	red	black	
.339	33	3100	-3,5	orange	orange	black	
.479	47	3150	-3,5	yellow	violet	black	
.689	68	3225	-3,6	blue	grey	black	
.101	100	3300	-3,7	brown	black	brown	
.151	150	3375	-3,8	brown	green	brown	
.221	220	3475	-3,9	red	red	brown	
.331	330	3575	-4,0	orange	orange	brown	
.471	470	3650	-4,1	yellow	violet	brown	
.681	680	3725	-4,2	blue	grey	brown	
.102	1 000	3825	-4,3	brown	black	red	
.152	1 500	3975	-4,5	brown	green	red	
.222	2 200	4125	-4,6	red	red	red	
.332	3 300	4250	-4,8	orange	orange	red	
.472	4 700	4350	-4,9	yellow	violet	red	
.682	6 800	4400	-5,0	blue	grey	red	
.103	10 000	4275	-4,8	brown	black	orange	
.153	15 000	4200	-4,7	brown	green	orange	
.223	22 000	4275	-4,8	red	red	orange	
.333	33 000	4350	-4,9	orange	orange	orange	
.473	47 000	4400	-5,0	yellow	violet	orange	
.683	68 000	4450	-5,1	blue	grey	orange	
.104	100 000	4500	-5,2	brown	black	yellow	
.154	150 000	4550	-5,2	brown	green	yellow	
.224	220 000	4600	-5,3	red	red	yellow	
.334	330 000	4625	-5,3	orange	orange	yellow	
.474	470 000	4650	-5,4	yellow	violet	yellow	



\* Replace dot in catalogue number (9th digit) by:  
 2 for a tolerance of 10% on R<sub>25</sub>, band IV is silver.  
 3 for a tolerance of 5% on R<sub>25</sub>, band IV is gold.

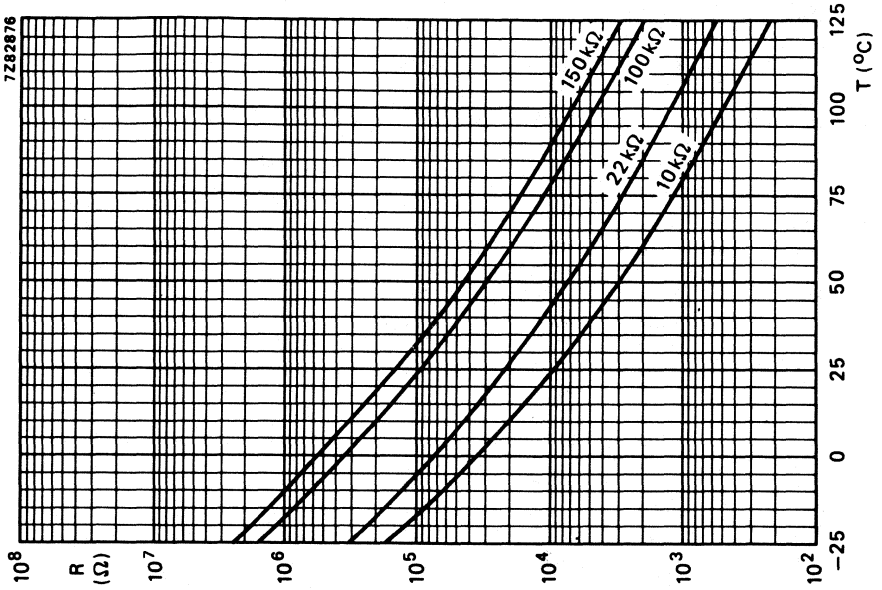

Fig. 4 Typical resistance/temperature characteristic.

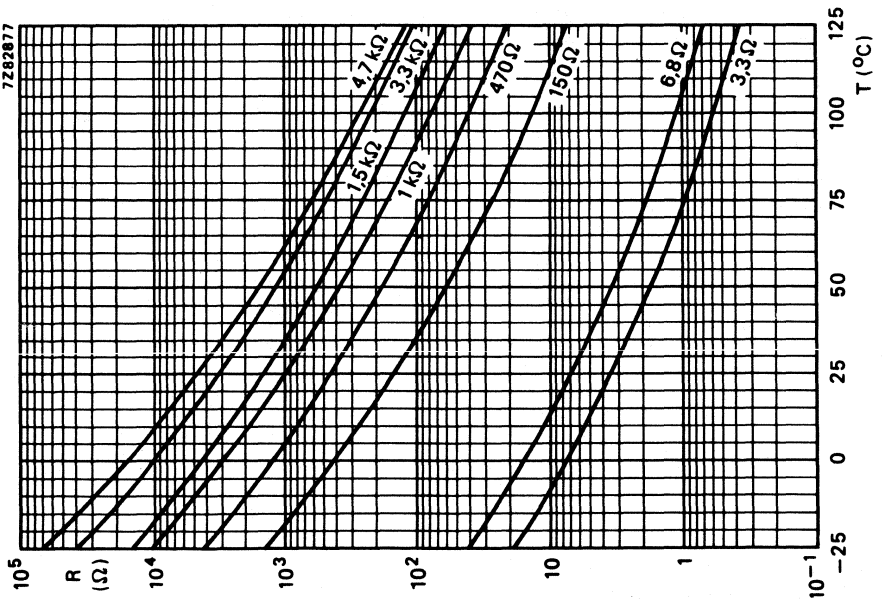

Fig. 3 Typical resistance/temperature characteristic.

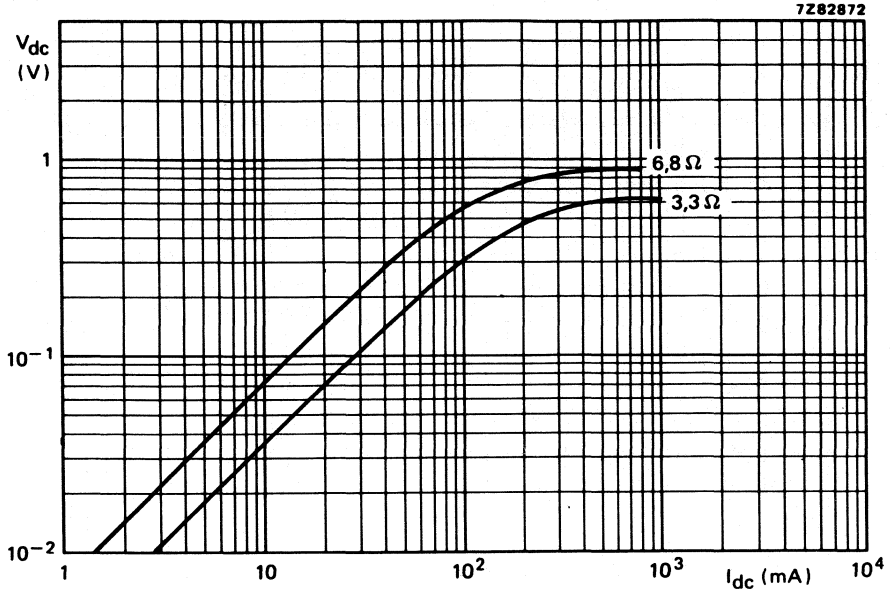

Fig. 5 Typical voltage/current characteristic,  $T_{amb} = + 25 \text{ }^\circ\text{C}$ , still air.

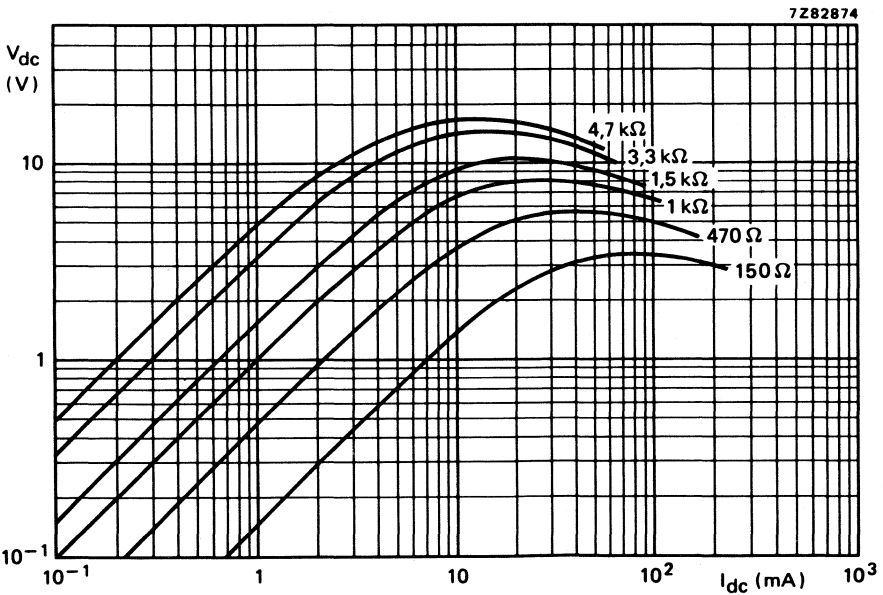

Fig. 6 Typical voltage/current characteristic,  $T_{amb} = + 25 \text{ }^\circ\text{C}$ , still air.

7Z82873

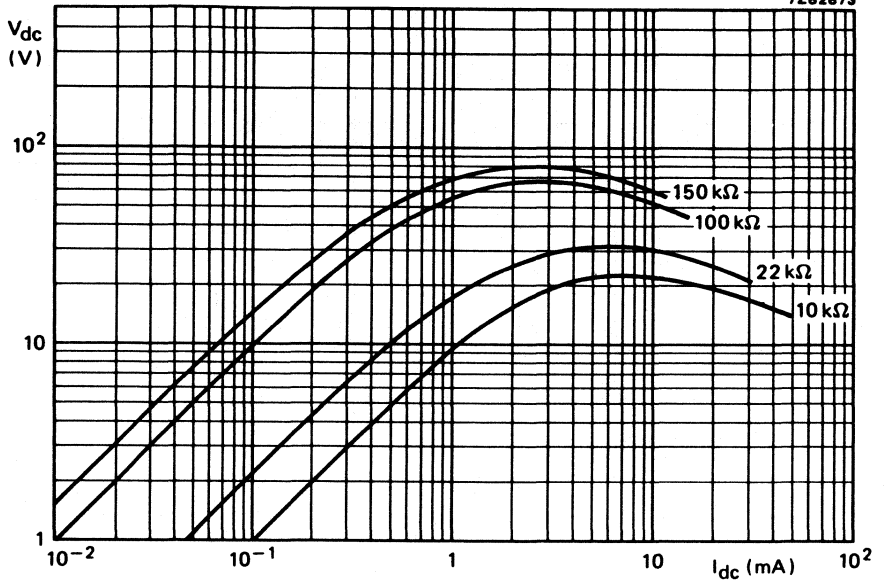

Fig. 7 Typical voltage/current characteristic,  $T_{amb} = + 25 \text{ }^\circ\text{C}$ , still air.

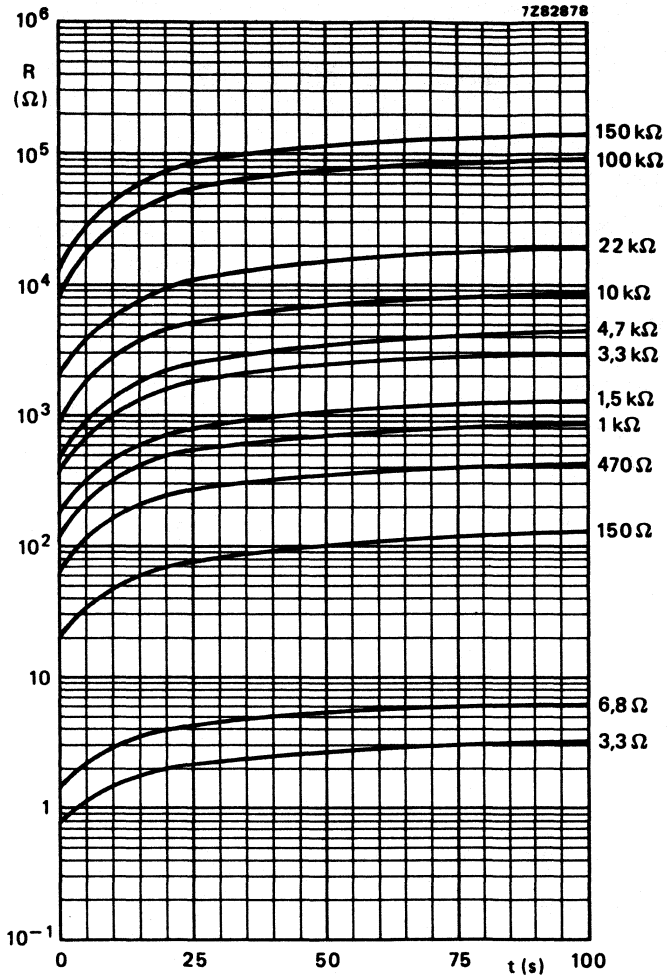

Fig. 8 Typical resistance/cooling time characteristic,  $T_{amb} = + 25 \text{ }^\circ\text{C}$ , still air,  $T_{start} = + 85 \text{ }^\circ\text{C}$ .

## NTC THERMISTORS

with mounting stud

### QUICK REFERENCE DATA

Resistance value at +25 °C	3,3 Ω to 470 kΩ (E6 series)
B <sub>25/85</sub> -value	2675 to 4650 K
Maximum dissipation	0,5 W
Dissipation factor	25 mW/K
Thermal time constant	20 s
Operating temperature range at zero power	-25 to +100 °C
at maximum power	0 to +55 °C

### APPLICATION

Suitable for all kinds of applications, especially when a good insulation and/or a good thermal contact with the chassis is required.

### DESCRIPTION

Disc thermistor with negative temperature coefficient mounted in the head of aluminium screws M4 and with two solid tinned copper wires.

### MECHANICAL DATA

#### Outline drawing

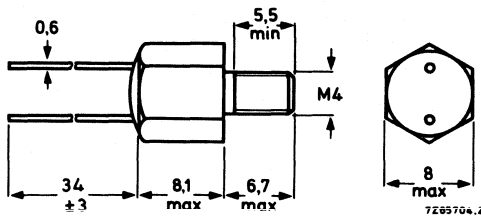

Fig. 1.

**Marking**

The last 4 digits of the catalogue number are printed on the stud according to Table 1. 

**Mass**

1,5 g approx.

**Mounting**

By means of a washer and M4 nut supplied with the device.  
Applied torque shall not exceed 1,2 Nm. Leads to be soldered.

**Robustness of terminations**

Tensile strength	10 N
Bending	5 N
Torque applied on screw	1,2 Nm max.

**Soldering**

Solderability	max. 240 °C, max. 4 s
Resistance to heat	max. 240 °C, max. 4 s

**PACKAGING**

100 thermistors in a cardboard box.

**ELECTRICAL DATA**

Maximum dissipation	0,5 W
Dissipation factor *	25 mW/K
Thermal time constant *	20 s approx.
Heat capacity	0,5 J/K approx.
Operating temperature range	
at zero power	-25 to +100 °C
at maximum power	0 to +55 °C
Dielectric withstanding voltage between terminals and screw	min. 100 V r.m.s.
Insulation resistance between terminals and screw at 100 V d.c.	min. 100 MΩ

See further Table 1.

For typical resistance/temperature and voltage/current characteristics, see pages 184/186 (type 2322 642 6....).

\* Measured when screw mounted on an aluminium heatsink of 100 cm<sup>2</sup>, thickness 1,5 mm, in still air, T<sub>amb</sub> = +25 °C.

Table 1 Catalogue number 2322 642 7....

suffix of catalogue number		R <sub>25</sub>	B <sub>25/85</sub> -value ± 5%	temperature coefficient at 25 °C %/K
tol. 5%	tol. 10%	Ω	K	
3338	2338	3,3	2675	-3,0
3478	2478	4,7	2750	-3,1
3688	2688	6,8	2800	-3,2
3109	2109	10	2875	-3,2
3159	2159	15	2950	-3,3
3229	2229	22	3025	-3,4
3339	2339	33	3100	-3,5
3479	2479	47	3150	-3,5
3689	2689	68	3225	-3,6
3101	2101	100	3300	-3,7
3151	2151	150	3375	-3,8
3221	2221	220	3475	-3,9
3331	2331	330	3575	-4,0
3471	2471	470	3650	-4,1
3681	2681	680	3725	-4,2
3102	2102	1 000	3825	-4,3
3152	2152	1 500	3975	-4,5
3222	2222	2 200	4125	-4,6
3332	2332	3 300	4250	-4,8
3472	2472	4 700	4350	-4,9
3682	2682	6 800	4400	-5,0
3103	2103	10 000	4275	-4,8
3153	2153	15 000	4200	-4,7
3223	2223	22 000	4275	-4,8
3333	2333	33 000	4350	-4,9
3473	2473	47 000	4400	-5,0
3683	2683	68 000	4450	-5,0
3104	2104	100 000	4500	-5,1
3154	2154	150 000	4550	-5,1
3224	2224	220 000	4600	-5,2
3334	2334	330 000	4625	-5,2
3474	2474	470 000	4650	-5,2





## NTC THERMISTORS disc

### QUICK REFERENCE DATA

Resistance values at 25 °C	150 Ω, 470 Ω, 1,5 kΩ, 4,7 kΩ
B25/85 value	3600 to 4300 K
Operating temperature range at zero power	-25 to + 125 °C
Max. dissipation at 25 °C	1,5 W
Dissipation factor	15 mW/K approx.
Thermal time constant	105 s approx.

### APPLICATION

General purpose.

### DESCRIPTION

The thermistors have a negative temperature coefficient. They consist of a disc with two tinned copper wires. They are not insulated nor lacquered. The thermistors are colour coded.



### MECHANICAL DATA

Outline drawing

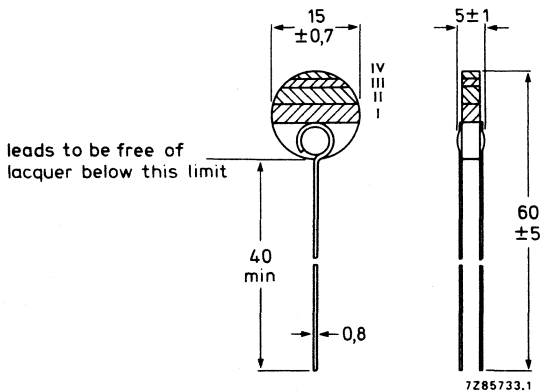

**Marking**

The thermistors are marked with three bands showing their resistance value ( $R_{25}$ ) in colour code (see Fig. 1); the types with a tolerance on  $R_{25}$  of 10% also have a forth band of silver.

**Mass**

2 g approximately.

**Mounting**

In any position by soldering

**PACKAGING**

100 thermistors in a cardboard box.

**ELECTRICAL DATA**

Table 1.

catalogue* number	$R_{25}$	$B_{25/85}$ - value $\pm 5\%$	$P_{max}$ at $T_{amb} = 25\text{ }^{\circ}\text{C}$	dissipation factor approx.	thermal time constant approx. s	colour code see Marking		
	$\Omega$	K	W	mW/K		I	II	III
2322 644 1.151	150	3600	1,5	15	105	brown	green	brown
1.471	470	3900	1,5	15	105	yellow	violet	brown
1.152	1500	4200	1,5	15	105	brown	green	red
1.472	4700	4300	1,5	15	105	yellow	violet	red

Tolerance on resistance value at 25 °C ( $R_{25}$ )  $\pm 20$  and  $\pm 10\%$  \*

Operating temperature range at zero power  $-25$  to  $+125\text{ }^{\circ}\text{C}$

\* Replace dot in catalogue number (9th digit) by: 1 for a tolerance of 20% on  $R_{25}$ .  
2 for a tolerance of 10% on  $R_{25}$ .

## NTC THERMISTORS

disc

### QUICK REFERENCE DATA

	2322 644 90004	2322 644 90005
Resistance value at +25 °C	82 Ω ± 20%	min. 15 Ω
Resistance at T <sub>amb</sub> = +25 °C, and I <sub>rms</sub> = 1,7 A and 2,2 A respectively	max. 0,85 Ω	max. 1 Ω
B <sub>25/85</sub> -value	4650 K	3350 K
Maximum current (r.m.s.)	1,7 A	2,2 A
Dissipation factor	19 mW/K	17 mW/K
Thermal time constant	115 s	148 s
Operating temperature range at zero power	-25 to +155 °C	-25 to +155 °C
at maximum power	0 to +55 °C	0 to +55 °C

### APPLICATION

For limiting surge current, e.g. diode and switch protection.

### DESCRIPTION

This thermistor has a negative temperature coefficient. It consists of a disc with two tinned copper wires. The thermistor body is neither lacquered nor insulated.

### MECHANICAL DATA

#### Outline drawing

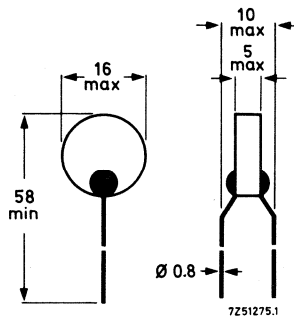

Fig. 1.

2322 644 90004  
2322 644 90005

**Marking**

The thermistors are not marked.

**Mass**

Type 2322 644 90004  
Type 2322 644 90005

3,2 g approximately  
4 g approximately

**Mounting**

In any position by soldering. Do not solder within 10 mm from the thermistor body.

**Robustness of terminations**

Tensile strength  
Bending

20 N  
10 N

**Soldering**

Solderability  
Resistance to heat

max. 240 °C, max. 4 s  
max. 240 °C, max. 4 s

→ **PACKAGING**

100 thermistors in a cardboard box.

**ELECTRICAL DATA**

	2322 644 90004	2322 644 90005	
R at 25 °C	82 ± 20%	min. 15	Ω
R at T <sub>amb</sub> = 25 °C, I <sub>rms</sub> = 1,7 A	max. 0,85		Ω
R at T <sub>amb</sub> = 25 °C, I <sub>rms</sub> = 2,2 A		max. 1	Ω
B <sub>25/85</sub> -value, approx.	4650	3350	K
Max. current (r.m.s.) at T <sub>amb</sub> = +55 °C	1,7	2,2	A
Dissipation factor, approx.	19	17	mW/K
Thermal time constant, approx.	115	148	s
Heat capacity, approx.	2,2	2,5	J/K
Operating temperature range			
at zero power	-25 to +155	-25 to +155	°C
at maximum power	0 to +55	0 to +55	°C
Max. repetitive peak voltage			
50-60 Hz	345	380	V

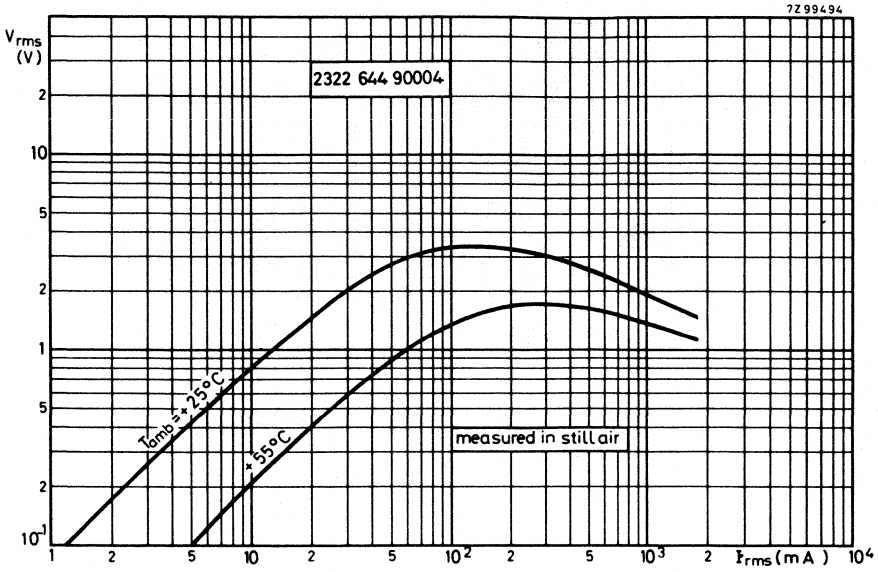

Fig. 2 Typical voltage/current characteristics.

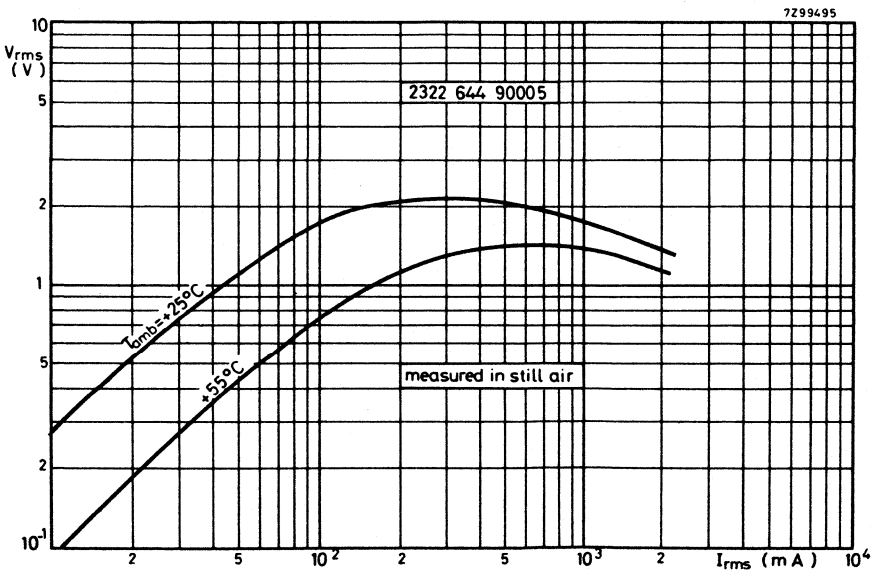

Fig. 3 Typical voltage/current characteristics.

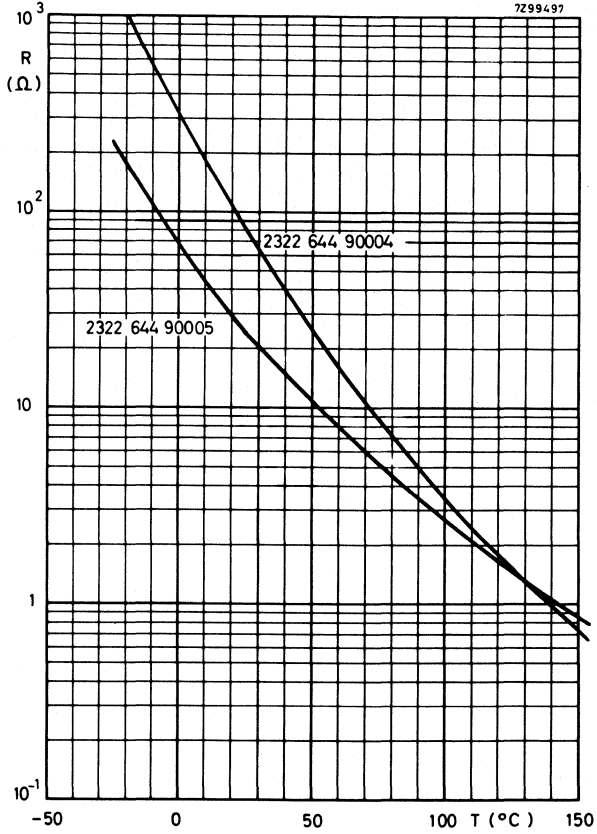

Fig. 4 Typical resistance/temperature characteristics.

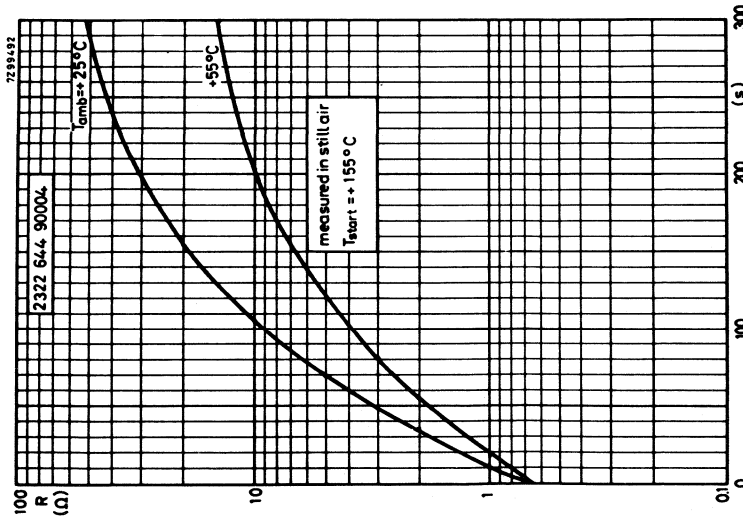
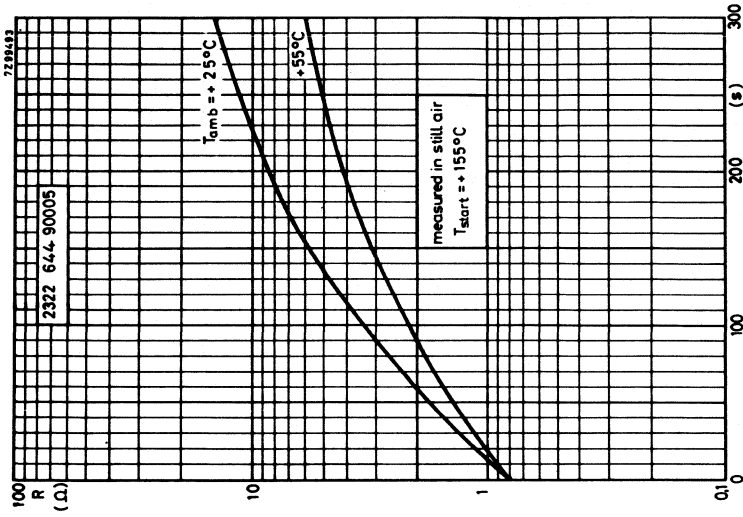

Fig. 7 Typical resistance/time (Cooling) characteristics.

Fig. 6 Typical resistance/time (Cooling) characteristics.







## NTC THERMISTOR

disc without leads

### QUICK REFERENCE DATA

Resistance value at +25 °C	5 Ω ± 20%
Resistance value at $I_{\text{rms}} = 2,2 \text{ A}$	max. 0,5 Ω
B <sub>25/85</sub> -value	2975 K
Maximum current (r.m.s.)	8 A
Operating temperature range at zero power	-25 to +155 °C
at maximum power	0 to +55 °C

### APPLICATION

For limitation of surge current.

### DESCRIPTION

Disc thermistor with negative temperature coefficient, provided with reinforced contacts.

### MECHANICAL DATA

#### Outline drawing

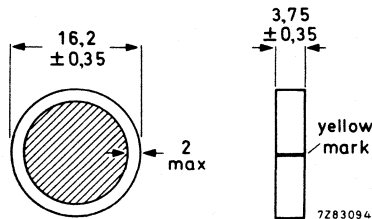

Fig. 1.

<b>Marking</b>	yellow stripe, see Fig. 1.
<b>Mass</b>	4,2 g approximately.
<b>Mounting</b>	In any position by clamping.
<b>Impact</b>	Free fall, 0,1 m.
<b>Inflammability</b>	Uninflammable

### PACKAGING

10 preformed sheets of polystyrene containing 75 items in a cardboard box. Resistance value and catalogue number are printed on the box.

**ELECTRICAL DATA**

Unless otherwise specified, measured according to IEC publication 539.

Resistance value at +25 °C	5 Ω ± 20%
Resistance value at $I_{rms} = 2,2$ A	max. 0,5 Ω
B25/85-value	2975 K
Temperature coefficient	-3,35%/K
Maximum current (r.m.s.)	8 A
Operating temperature range at zero power	-25 to +155 °C
at maximum power	0 to +55 °C

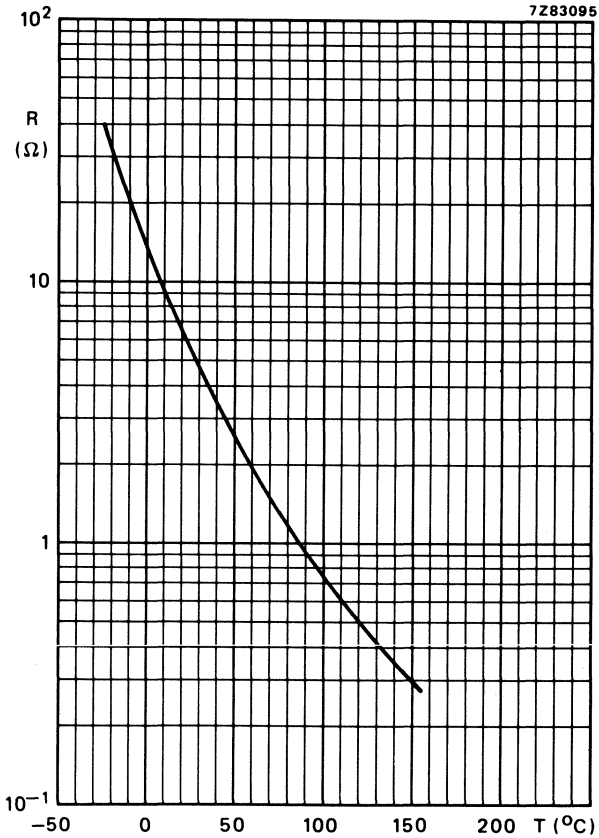

Fig. 2 Typical resistance/temperature characteristic.

## POSITIVE TEMPERATURE COEFFICIENT THERMISTORS (PTC)



	<b>page</b>
<b>Survey</b>	<b>202</b>
<b>Introduction</b>	<b>205</b>
<b>Electrical properties</b>	<b>206</b>
<b>Explanation of terms</b>	<b>211</b>
<b>How to measure PTC thermistors</b>	<b>214</b>
<b>Applications</b>	<b>215</b>
<b>Data sheets</b>	<b>219</b>





# PTC THERMISTORS



## SURVEY

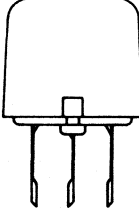
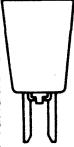

	maximum voltage	R <sub>25</sub> Ω	switch temperature °C	dissipation factor mW/K	temperature coefficient %/K	catalogue number
DISC 	300 V (r.m.s.)	8,75 to 17,5	120			2322 678 93002
	400 V (r.m.s.)	70 to 100	105	11,5	35	2322 662 93006
DISC with leads 	16 V (d.c.)	≤ 0,6	85	27	10	2322 664 91086
	25 V (d.c.)	30 to 250	70 to 150	5,7	18 to 38	2322 672 91002 to 2322 672 91035
	25 V (d.c.)	50-60 ± 30%	30 to 105	7	7 to 40	2322 660 91006 to 2322 660 91009
	25 V (d.c.)	250 ± 25%	6	6	5	2322 660 91001
	40-50 V (d.c.)	30 to 50 ± 15 Ω	25 to 110	6-8,5	9 to 75	2322 661 91002 to 2322 661 91005
	180 V (d.c.)	36 to 50	115	13	35	2322 662 91001
	245 V (r.m.s.)	750 to 1500	115	7	26	2322 660 93001
	265 V (r.m.s.)	45 to 60	75	20	20	2322 662 93036
	265 V (r.m.s.)	100 ± 20%	75	15,3	35	2322 662 93066

Overload protection	60 V (d.c. and 245 V r.m.s.)	1,65 to 55 3,7 to 1500	115 115				selection on pages D125-D127
Loudspeaker protection	18 V (r.m.s.) 18 V (r.m.s.)	max. 1,1 max. 1,1	100 140			6 8	2322 662 91016 2322 663 91006
Motor protection 	15 V (d.c.)	30 to 250	68 to 137	7		18 to 38	2322 672 92045 to 2322 672 92053
DUAL PTC for degaussing 	245 V (r.m.s.) 265 V (r.m.s.) 140 V (r.m.s.) 265 V (r.m.s.)	25 and 8 30 and 8 10 and 400 to 2400 40 and 1000 to 6000	75 70 and 170	13,5		23 and 25 25 and 25 16 and 20	2322 662 98001 2322 662 98003 2322 662 98013 2322 662 98009
DISC for compensation of telephone line variations 	33 V (d.c.)	115 ± 25	97	3,9		10	2322 672 98001
DMS for motor start 	34 V (d.c.)	120 ± 30	145			8	2322 670 90003
	300 V (r.m.s.)	8,75 to 17,5	120				2322 678 93001



# PTC THERMISTORS

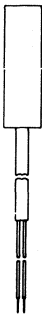

type	voltage range r.m.s. V	max. inrush power W	operating temp. after 20 min °C	measured at V	diameter mm	catalogue number
<b>HEATING ELEMENT</b> 	100 to 265	500	—	220	12,7	2322 680 04022
	100 to 265	500	—	220	14,85	2322 680 90019
	100 to 240	500	—	220	12,45	2322 680 90047
	100 to 265	200	—	110	10,60	2322 680 90136
	100 to 265	1000	160	220	14,8	2322 680 00001
	100 to 265	1000	160	220	10,8	2322 680 03001
	100 to 265	1000	215	220	12,7	2322 680 04001
	100 to 145	1000	215	220	12,7	2322 680 04002
	100 to 265	1000	160	220	12,7	2322 680 04003
	100 to 145	1000	160	220	12,7	2322 680 04004

## INTRODUCTION

Positive Temperature Coefficient (PTC) thermistors are resistors with a high positive temperature coefficient of resistance. They differ from NTC thermistors in the following aspects:

- The temperature coefficient of a PTC thermistor is positive only *between certain temperatures*, outside this range the temperature coefficient is either zero or negative.
- The absolute value of the temperature coefficient of PTC thermistors is usually much higher than that of NTC thermistors.

PTC thermistors are used as current limiters, temperature sensors and protectors against overheating in equipment such as electric motors. They are also used as level indicators, time delay devices, thermostats, compensation resistors, etc. See chapter 'Applications'.

PTC thermistors are prepared from BaTiO<sub>3</sub>, or solid solutions of BaTiO<sub>3</sub> and SrTiO<sub>3</sub> in a similar way as NTC thermistors. Extra electrons on the Ti-ions are created by the introduction of foreign ions having a different valency. In these compounds there are two possibilities: substitution of trivalent ions like La<sup>3+</sup> or Bi<sup>3+</sup> for Ba<sup>3+</sup> or substitution of pentavalent ions like Sb<sup>5+</sup> or Nb<sup>5+</sup> for Ti. Both methods lead to identical results. If prepared in the absence of oxygen, these semiconductors have a weakly negative temperature coefficient. A strong positive temperature coefficient is obtained by firing the ceramic samples in an oxygen-rich atmosphere. This is caused by the penetration of oxygen along pores and crystal boundaries during cooling after the firing process. The oxygen atoms, absorbed on the crystal surfaces attract electrons from a thin zone of the semiconducting crystals. In this way electrical potential barriers are formed consisting of a negative surface charge with, on both sides, thin layers having a positive space charge resulting from the now uncompensated foreign ions. These barriers cause an extra resistance of the thermistor.

$$R_b \propto \frac{1}{a} e^{eV_b/kT} \quad (\propto = \text{directly proportional to})$$

Here 'a' represents the size of the crystallites, thus  $\frac{1}{a}$  is the number of barriers per unit length of the thermistor.  $V_b$  represents the electrical potential of the barriers. As  $V_b$  is inversely proportional to the value of the dielectric constant of the crystals it is clear that  $R_b$  is extremely sensitive to variations of the dielectric constant. Such a variability of the dielectric constant is a special property of materials with a ferroelectric nature like BaTiO<sub>3</sub> and its solid solutions. Above their ferroelectric Curie temperature  $\theta$  the relative dielectric constant decreases with temperature according to

$$\epsilon_r = \frac{C}{T - \theta}$$

where C has a value of approximately 10<sup>5</sup> K. As a result the resistivity increases steeply just above the Curie temperature. Below the Curie temperature the barriers are weak or absent, partly as a result of the high effective dielectric constant of BaTiO<sub>3</sub> in strong fields and partly as a result of the spontaneous polarization of the crystals which may compensate the boundary charges.

At very high temperatures, i.e. above 160 to 200 °C the electrons captured at the boundaries are gradually liberated, causing the potential barriers to decrease in strength. This means that the PTC loses its properties and may eventually act as an NTC if the temperature becomes too high. Therefore the applications of PTC thermistors are restricted by a certain temperature limit.

As the PTC effect is caused by crystal boundary barriers the extra resistance  $R_b$  is shunted by a high parallel capacitance  $C_b$ . This leads to a frequency dependence of extra impedance  $Z_b$  up to 5 MHz. The characteristic properties described in the following paragraphs are thus restricted to this frequency range.



## ELECTRICAL PROPERTIES

### RESISTANCE/TEMPERATURE CHARACTERISTICS

Figure 1 shows typical resistance/temperature characteristics of an NTC and a PTC thermistor.

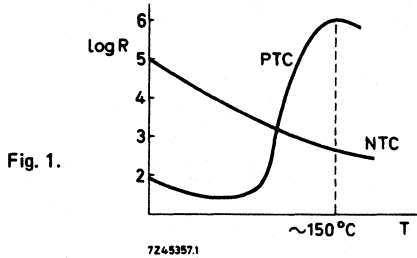

### VOLTAGE/CURRENT CHARACTERISTICS

Static voltage/current characteristics show the current limiting ability of PTC thermistors. Up to a certain voltage the V/I characteristic follows Ohm's law, but the resistance increases when the PTC is heated so much by the current it is carrying that its temperature reaches the switch temperature. See Fig. 2. Of course the V/I characteristic depends on the ambient temperature and on the heat transfer coefficient to the ambience. In Fig. 2 the characteristic is plotted on a linear scale. In practice, however, logarithmic scales are used more often, see Fig. 3. PTC thermistors show some voltage dependency. At higher voltages the resistance is somewhat lower than expected. It is possible to calculate accurately the top of the V/I characteristic if the R/T characteristic and the dissipation constant are known:

The power dissipation is:  $P = I^2 R$

Thus a small increase in P:  $\Delta P = 2 I R \Delta I + I^2 \Delta R$

At the top of the V/I curve  $\Delta I_p = 0$ , thus:

$$\Delta P_p = I_p^2 \Delta R_p \quad (\text{p indicates that the values are taken at the top of the V/I characteristic}).$$

Also  $\Delta P = D \Delta T$ , thus:

$$\Delta P_p = D \Delta T_p = I_p^2 \Delta R_p$$

or

$$\frac{\Delta T_p}{\Delta R_p} \cdot D = I_p^2$$



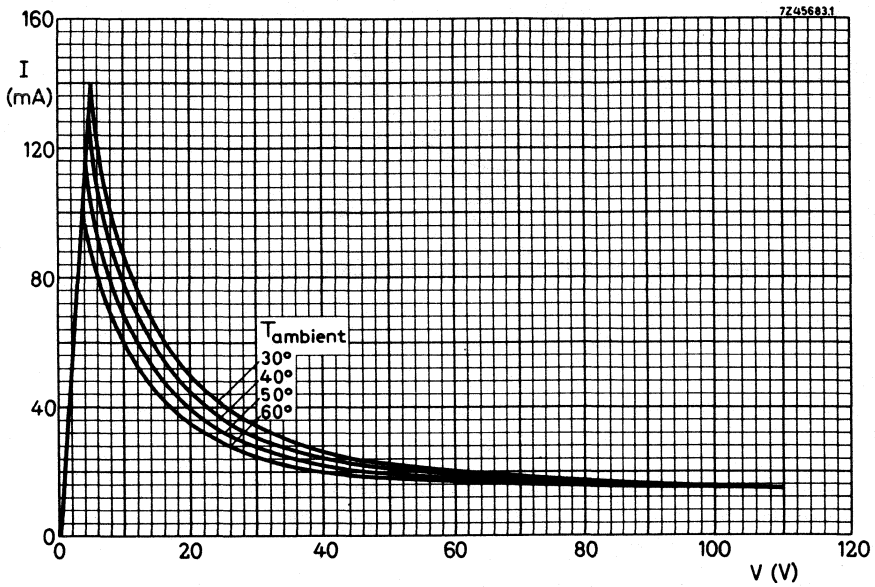

Fig. 2 Voltage/current characteristics of a PTC thermistor on a linear scale, with ambient temperature as a parameter.

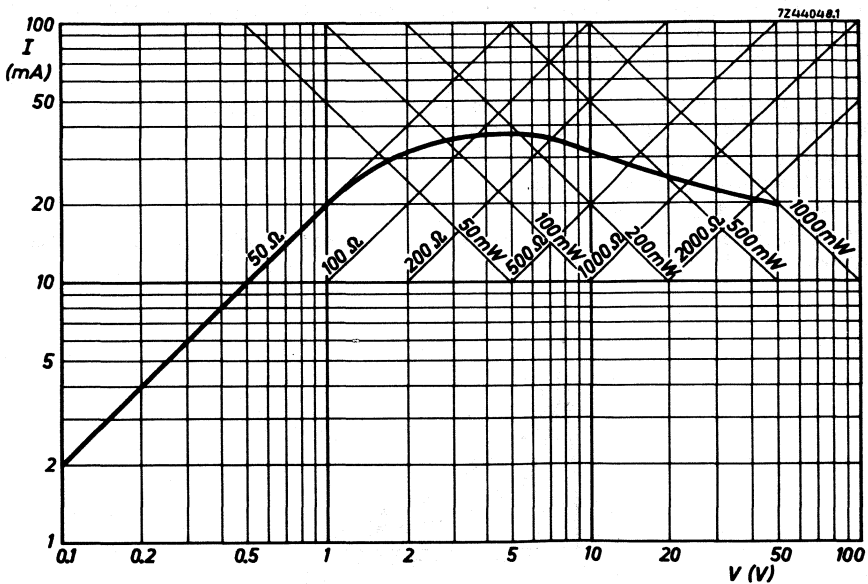

Fig. 3 Voltage/current characteristic on logarithmic scale.



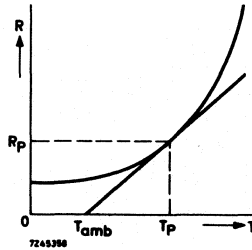

Fig. 4 Part of the resistance/temperature characteristic on a linear scale.

From Fig. 4:

$$\frac{\Delta T_p}{\Delta R_p} = \frac{T_p - T_{amb}}{R_p}$$

so

$$I_p = \sqrt{\frac{D(T_p - T_{amb})}{R_p}}$$

For given ambient temperature ( $T_{amb}$ ) and  $D$ ,  $R_p$  and  $T_p$  can easily be found; see Fig. 4.

The calculation shows that if  $D$  is increased  $n$  times (e.g. by a heatsink, or ambience with better heat conductivity)  $I_p$  increases  $\sqrt{n}$  times.

### PTC THERMISTOR IN SERIES WITH A LOAD

From the voltage/current characteristic it can be shown that because of the non-linearity of the PTC-curve three working points are possible when a load  $R$  is connected in series with the PTC. See Fig. 5. The characteristic of the load is a straight line intersecting the voltage co-ordinate at  $V_a$ , the supply voltage.  $P_1$  and  $P_2$  are stable working points;  $P_3$  is unstable.

When the voltage  $V_a$  is applied to the series connection, equilibrium will be reached at  $P_1$ , a point with a relatively high current.  $P_2$  can only be reached when the top of the  $V/I$  curve comes below the load characteristic. This may happen in the following cases:

- $V_a$  increases, see Fig. 6;
- the ambient temperature increases, see Fig. 7;
- the load resistance decreases, see Fig. 8.

The PTC thermistor is thus an excellent protector, limiting the load to a safe value if supply voltage, temperature or current exceeds a critical value.

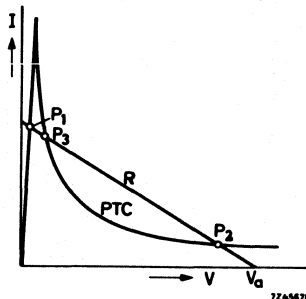

Fig. 5 PTC thermistor in series with a load showing the possible working points.

Fig. 6 PTC thermistor in series with a load showing the influence of the supply voltage  $V_a$ .

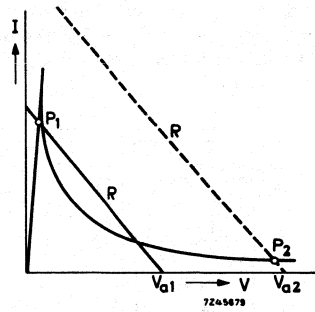

Fig. 7 PTC thermistor in series with a load showing the influence of the ambient temperature.

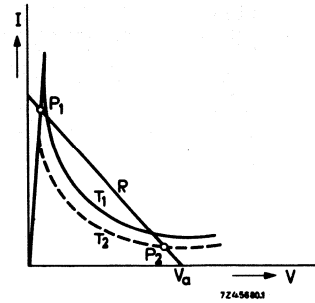
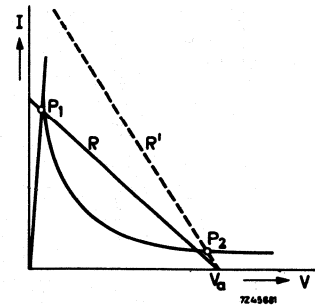

Fig. 8 PTC thermistor in series with a load showing the influence of the load resistance.



# PTC THERMISTORS

## CURRENT/TIME CHARACTERISTICS

If a PTC thermistor is connected in series with a resistance of such a value that the top of the V/I curve lies under the load line, the PTC will heat up till the stable working point  $P_2$  is reached (Fig. 9). The time it takes to reach this point depends very much on the value of the load  $R$  (Fig. 10) and the ambient temperature.

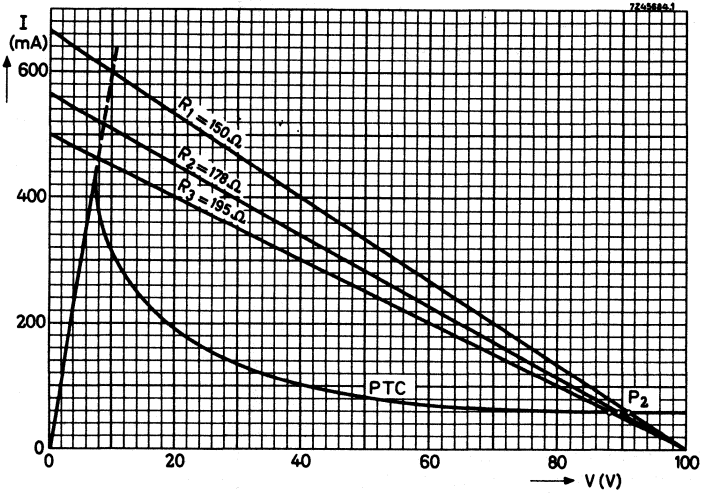

Fig. 9 PTC thermistors in series with different resistors.

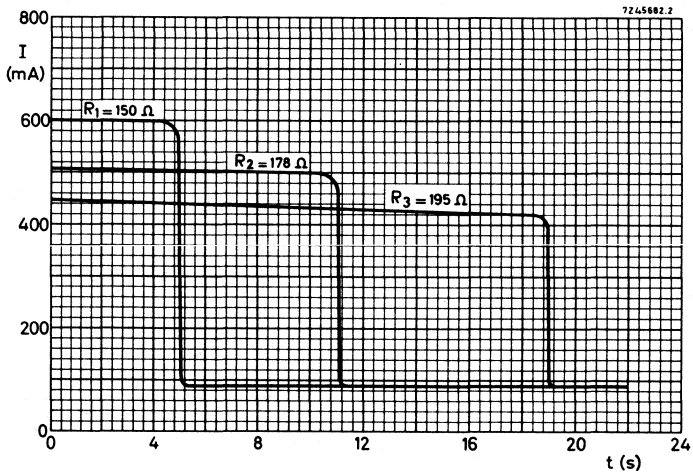

Fig. 10 Current/time characteristics showing the influence of the load.

EXPLANATION OF TERMS

Switch temperature ( $T_s$ )

The switch temperature  $T_s$  is the higher of the two temperatures at which the resistance  $R_s$  is twice the minimum resistance  $R_{min}$  (see Fig. 11).

So, at  $T_s > T_{Rmin}$ :  $R_s = 2 R_{min}$ .

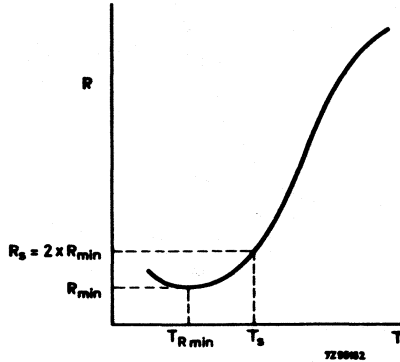

Fig. 11.

Temperature coefficient ( $\alpha$ )

The temperature coefficient  $\alpha = \frac{1}{R} \frac{dR}{dT}$ .

For R-T curves plotted on a log R-lin T scale:

$$\alpha = \frac{d \ln R}{dT} = \frac{1}{0,4343} \cdot \frac{d \log R}{dT}$$

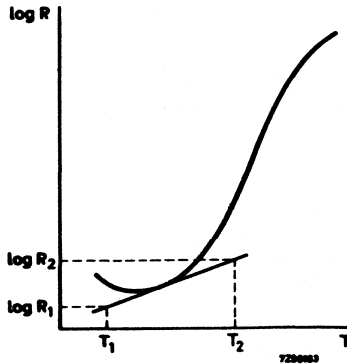

Fig. 12.

$\alpha$  can be calculated from

$$\alpha = \frac{100}{0,4343} \cdot \frac{\log R_2 - \log R_1}{T_2 - T_1} \% / K$$

where  $R_1$  and  $R_2$  are points on the tangent and  $T_1$  and  $T_2$  are the corresponding temperatures.

# PTC THERMISTORS

In the data sheets the maximum temperature coefficient is given, this is the  $\alpha$  measured at the point of inflection of the  $\log R$ -in  $T$  characteristic, i.e. the point where  $\frac{d^2 \log R}{dT^2} = 0$ , see Fig. 13.

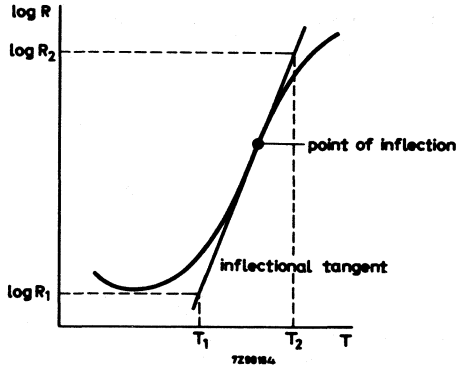

Fig. 13.

When one resistance decade is taken ( $R_2 = 10 R_1$ ) the formula reduces to

$$\alpha = \frac{100}{0,4343} \cdot \frac{1}{T_2 - T_1} \% / K$$

### Thermal time constant ( $\tau$ )

The thermal time constant represents the time required for a thermistor to change 63,2% of the total difference between its initial and final body temperatures when subjected to a step function change in temperature under zero-power conditions.

The  $\tau$  given in the data is found as follows (for  $T_s > 25^\circ C$ ):

Measure  $T_1$ , the temperature of the PTC at  $V_{max}$ , at an ambient temperature of  $T_0 = 25^\circ C$ ;  $T_s$  is known, so  $\tau$  can be calculated from:

$$\tau = \frac{t}{\ln (T_1 - T_0) / (T_s - T_0)}$$

where  $t$  is the time required for cooling the PTC from  $T_1$  to  $T_s$  in still air at  $25^\circ C$ .

### Voltage dependence

PTC thermistors show a voltage dependence. This effect can be explained with the aid of a parallel connection of an "ideal PTC" having no voltage dependence and an "ideal VDR" for which the relation between voltage and currents is:

$$V = C \cdot I^\beta$$

See Fig. 14.

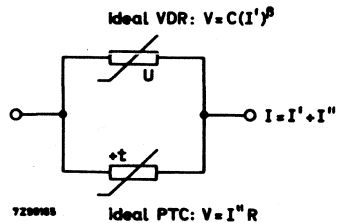

Fig. 14.

Plotted on a log I - log V scale at an arbitrary constant temperature the ideal PTC and the ideal VDR characteristics are straight lines, see Fig. 15.

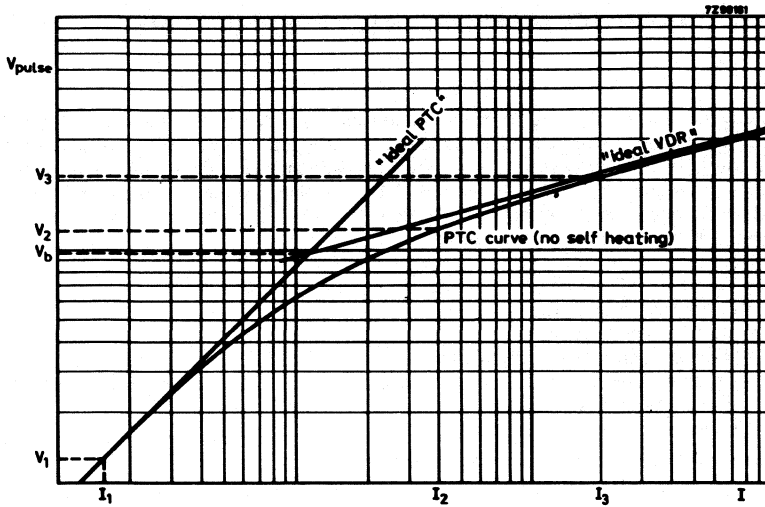

Fig. 15.

These lines coincide with the PTC curve (measured under pulse conditions to avoid internal heating) at low voltages where the ohmic behaviour is the deciding factor, and at high voltages where the VDR effect becomes more significant.

Two aspects of the voltage dependence are specified in the data sheets:

**Balance voltage ( $V_b$ )**

Where the two straight lines intersect, the current through the ideal PTC is equal to the current through the ideal VDR. The voltage at which this occurs is called the balance voltage  $V_b$  and is specified at a certain temperature.

**Voltage dependence ( $\beta$ )**

The  $\beta$  of the ideal VDR is a measure of the voltage dependence of the PTC and can be calculated using the formula:

$$\beta = \frac{\log V_3/V_2}{\log (I_3 - V_3/R)/(I_2 - V_2/R)}$$

where  $V_3$  and  $V_2$  are pulse voltages  $> V_b$  and  $R = \frac{V_1}{I_1}$ , measured at  $V_1 \leq 1,5$  V (d.c.).

$\beta$  is also specified at a certain temperature.

$V_b$  and  $\beta$  are useful parameters for estimating the voltage dependence of a particular PTC thermistor.



## HOW TO MEASURE PTC THERMISTORS

For general information regarding measuring techniques and apparatus refer to the section "How to measure NTC thermistors", which covers the same topics. As PTC thermistors often show a very high temperature coefficient especially at high temperatures, measurements at these high temperatures must be carried out with particular care. Even an error of 0,1 K can give an error in resistance of a few per cent. Specially calibrated thermometers have to be used. Stem correction has to be applied; deviations of more than 0,1 K may result if it is not used.

The stem correction formula for fluid thermometers is:

$$T_c = T_o + F \cdot L (T_o - T_m),$$

where:  $T_c$  = corrected temperature;

$T_o$  = observed temperature;

$T_m$  = mean temperature of exposed stem;

$L$  = length of the exposed column in K above the surface of the substance whose temperature is being determined;

$F$  = correction factor.

$F$  is approximately 0,00016 for a mercury thermometer.

For example with  $T_o = 110\text{ }^\circ\text{C}$ ,  $T_m = 70\text{ }^\circ\text{C}$  and  $L = 50\text{ K}$ :  $T_c = 110,32\text{ }^\circ\text{C}$ , thus without stem correction an error of more than 0,3 K would have been made. It is also necessary to measure the resistance with a voltage below 2 V in order not to heat the PTC and also to diminish voltage-dependent effects.

### TOLERANCES

The resistances of standard PTC thermistors are specified at

(1) 25 °C;

(2) A temperature above the switch temperature.

The switch temperature is also given.

For each standard type tolerances are specified for  $R_{25}$  and the high-temperature resistance. The tolerance on switch temperature is not specified; normally it is only a few K.

Special types are often specified according to the requirements for the particular application. The PTC thermistors for motor control, for instance, can be specified at a high temperature with a rather close tolerance, while the tolerance below the switch temperature, being less important, is much greater. PTC thermistors for current limiting applications are in most cases specified in terms of voltage and current.

It will be clear that the specification and the tolerances of PTC thermistors depend on the application, and are not limited to the standard range published in this book.



## APPLICATIONS

The applications of PTC thermistors can be classified in two main groups:

- Applications where the temperature of the PTC is primary determined by the temperature of the ambient medium.
- Applications where the temperature of the PTC is primary determined by the current through the PTC thermistor.

The first group comprises applications such as temperature-measurement and control and circuits for protection against excessive temperatures (e.g. motor protection.)

The second group includes applications such as current stabilization and current sensitive switching or overload protection, relay retardation, fluid-level indication and circuits for protection against over-voltages and short circuits. Also heating applications.

### ADVICE

Do not apply a voltage above  $V_{max}$  to the PTC, since this may destroy the thermistor.

Do not connect PTC thermistors in series in order to obtain higher voltages or wattages: this may cause one PTC to heat up faster than the other(s) resulting in too high a voltage across this particular PTC.

If special PTC characteristics are required which cannot be found in this book please specify your requirements as they can perhaps be fulfilled by one of our non-listed types.

### APPLICATION EXAMPLES

#### Protection against over-load or current sensitive switching

As soon as the current increases the PTC limits it to a safe value.

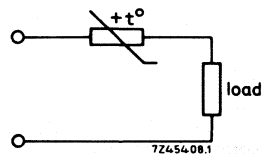

#### Spark suppression

A PTC across the switch acts as a spark suppressor. When the switch opens the low resistance of the cold PTC prevents sparking.

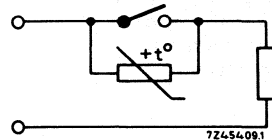

# PTC THERMISTORS

## Current stabilization

By using a parallel resistor a current stabilization circuit is obtained that compensates slowly varying supply voltages.

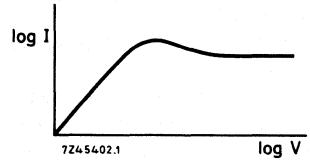
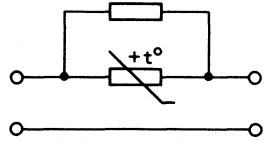

## Delaying action relays

A certain time after applying the voltage the relay is activated.

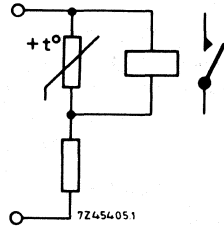

## Temperature protection of electric motors

As soon as one or more windings become too hot the motor is switched-off.

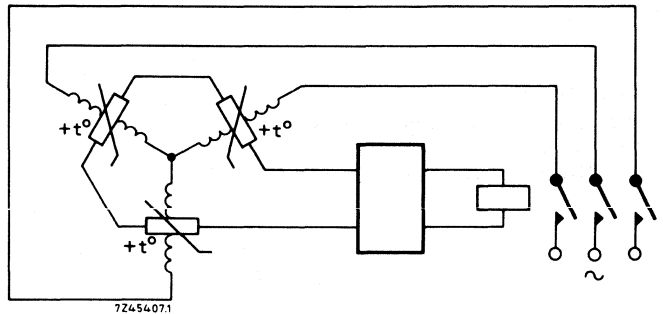

**Alarm installation**

The PTC reacts on ambient temperature (too low or too high).

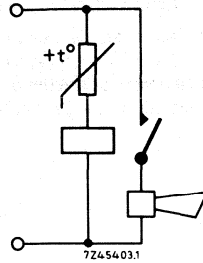

**Time delay circuit**

When the button is pressed the relay is activated and the lamp lights up. After some time the relay falls off due to the increase in resistance of the PTC.

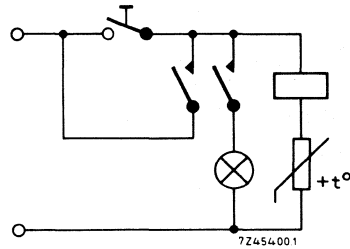

**Liquid-level indication**

The PTC thermistors above the fluid-level will be heated to a temperature above  $T_{switch}$ . When immersed they are cooled so that their resistance reduces.

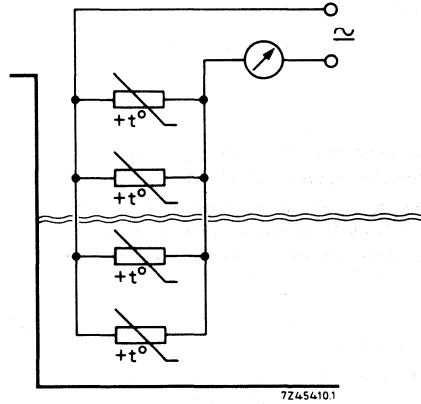

**Temperature compensation of transistor circuits**

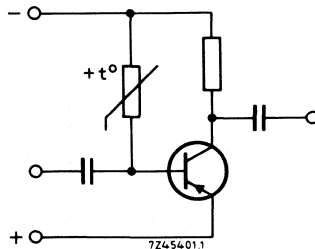

# PTC THERMISTORS

## Thermostatically-controlled heating circuits

Two principal circuits are possible. In the first circuit the PTC thermistor acts as a control element and as a heater at the same time, while in the second circuit it functions only as a control element.

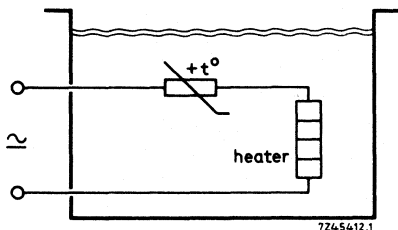
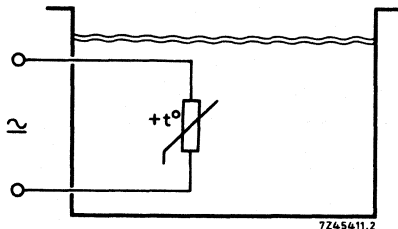

## Heating

As e.g. used in hair curling tongs.

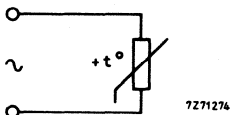

## Protection of electric motors against overheating due to blocking

The increased current heats the PTC to its switch temperature. As a result the total dissipated power is reduced to a safe value.

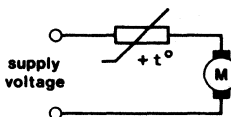

## Loudspeaker protection

Protection of squawker and tweeter in a 3-way loudspeaker system.

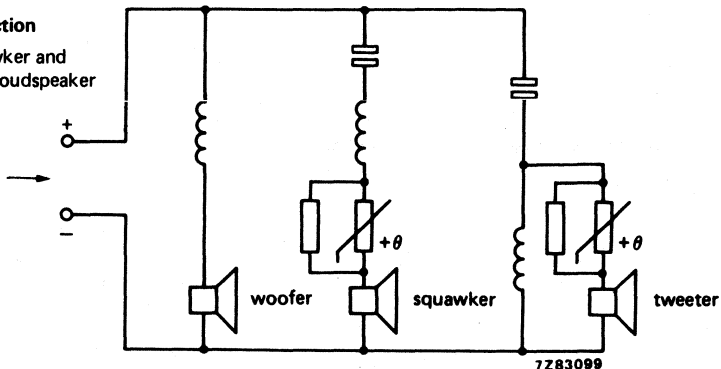

## PTC THERMISTOR

disc

### QUICK REFERENCE DATA

Resistance value at +25 °C	250 $\Omega$ $\pm$ 25%
Resistance value at +80 °C	3700 $\Omega$ $\pm$ 30%
Switch temperature	+6 °C approx.
Temperature coefficient	+5%/K approx.
Max. voltage at $T_{amb} = +55$ °C	25 V d.c.
Dissipation factor	6 mW/K approx.
Operating temperature range at zero power at $V_{max}$	-25 to +155 °C 0 to +55 °C

### APPLICATION

Temperature compensating and temperature measurement purposes.

### DESCRIPTION

The thermistor has a positive temperature coefficient. It consists of a disc with two tinned copper wires. The thermistor body is blue lacquered but not insulated.

### MECHANICAL DATA

#### Outlines

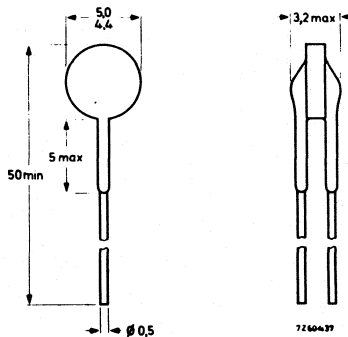

Mass 0,3 g approximately

Mounting In any position by soldering

#### Robustness of terminations

Tensile strength 10 N

Bending 5 N

#### Soldering

Solderability max. 240 °C, max. 4 s

Resistance to heat max. 265 °C, max. 11 s

**ELECTRICAL DATA**

Resistance *	
at +25 °C ( $T_{ref}$ )	250 $\Omega$ $\pm$ 25%
at +80 °C	3700 $\Omega$ $\pm$ 30%
Switch temperature	$\sim$ +6 °C
Temperature coefficient	$\sim$ +5%/K
Dissipation factor **	$\sim$ 6 mW/K
Heat capacity **	$\sim$ 0,1 J/K
Thermal time constant **	$\sim$ 17 s
Operating temperature range	
at zero power	-25 to +155 °C
at $V_{max}$	0 to +55 °C
Voltage dependence at +155 °C	0,25 approx.
Balance voltage (d.c.)	13 V approx.
Maximum voltage (d.c.)	25 V

**PACKAGING**

→ 500 thermistors in a cardboard box.

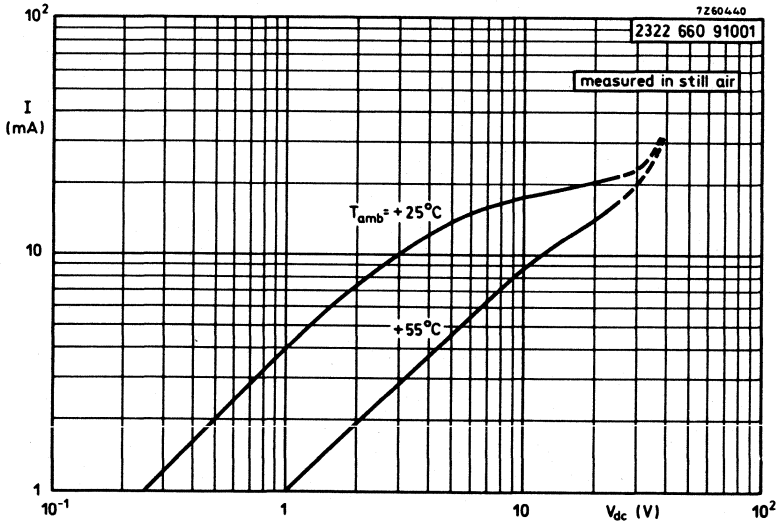

Fig. 2 Typical current/voltage characteristics.

\* Measuring voltage not exceeding 1,5 V(d.c.) to avoid internal heating.

\*\* Measurement made with specimen in phosphor bronze clips in still air.

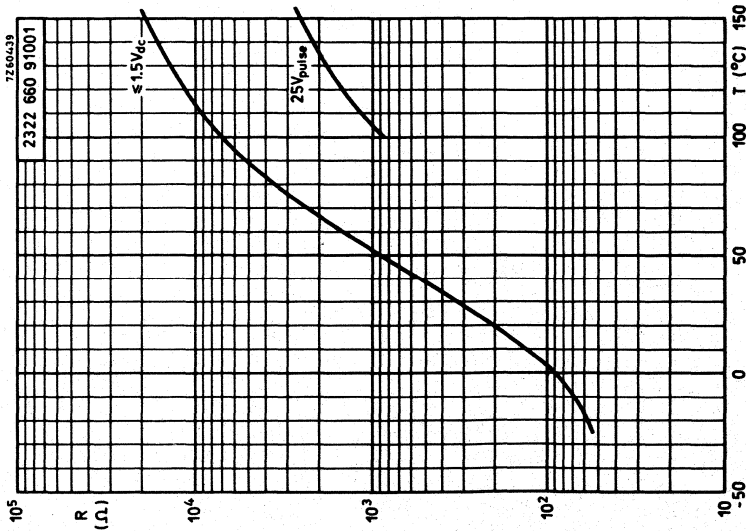
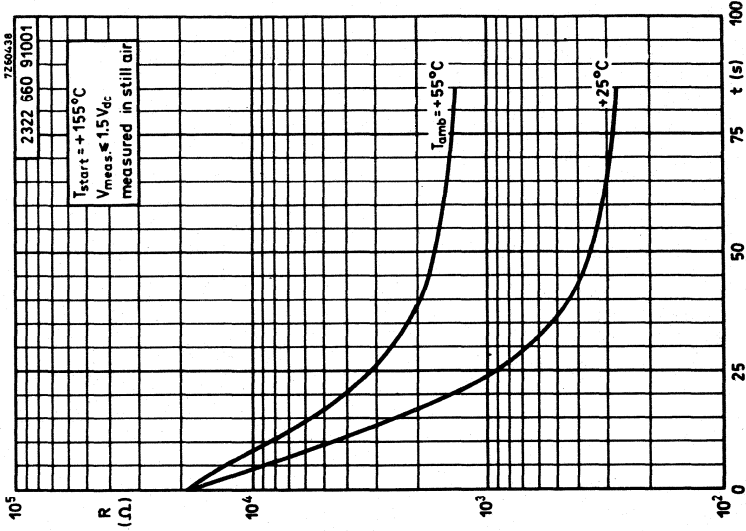

Fig. 4 Typical resistance/time (cooling) characteristics.

Fig. 3 Typical resistance/temperature characteristics.



2322 660 91006  
to  
2322 660 91009

## PTC THERMISTORS

### disc

#### QUICK REFERENCE DATA

Resistance values at +25 °C	50 and 60 Ω ± 30%
Resistance at other temperatures	} see table
Switch temperature	
Temperature coefficient	
Max. voltage (d.c.)	25 V
Dissipation factor	~ 7 mW/K
Operating temperature range	
at zero power	-10 to +125 °C *
at V <sub>max</sub>	0 to +55 °C

#### MECHANICAL DATA

##### Outlines

catalogue number	colour band
2322 660 91006	red
2322 660 91007	orange
2322 660 91008	yellow
2322 660 91009	green

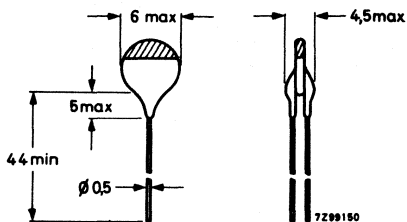

Fig. 1.

#### APPLICATION

General purpose.

#### DESCRIPTION

The thermistors have a positive temperature coefficient. They consist of a disc with two tinned copper wires. The thermistor body is blue lacquered but not insulated.

#### Marking

The thermistors are marked with a colour band at the top of the body according to Fig. 1.

**Mass**            0,4 g approximately

**Mounting**        In any position by soldering

#### PACKAGING

→ 500 thermistors in a cardboard box.

\* Type 2322 660 91009: -10 to +150 °C.



**ELECTRICAL DATA**

	catalogue number 2322 660 followed by				
	91006	91007	91008	91009	
Resistance *					
at 25 °C	60	50	50	50	Ω
at 125 °C	3 to 15	100 to 500	50 to 500		kΩ
at 150 °C				0,1 to 1,2	MΩ
Switch temperature	30	50	80	105	°C
R <sub>max</sub> at T <sub>s</sub>	100	300	400	400	Ω
Temperature coefficient	7	16	23	40	%/K
Heat capacity **	0,13	0,13	0,13		J/K
Thermal time constant **	20	18	18		s
Voltage dependence β	0,19	0,17	0,18		
Balance voltage (d.c.)	35	12,5	23		V

Tolerance on R<sub>25</sub> ± 30%  
 Max. voltage (d.c.) 25 V  
 Dissipation factor ~ 7 mW/K  
 Operating temperature range  
 at zero power -10 to +125 °C \*\*\*  
 at V<sub>max</sub> 0 to +55 °C

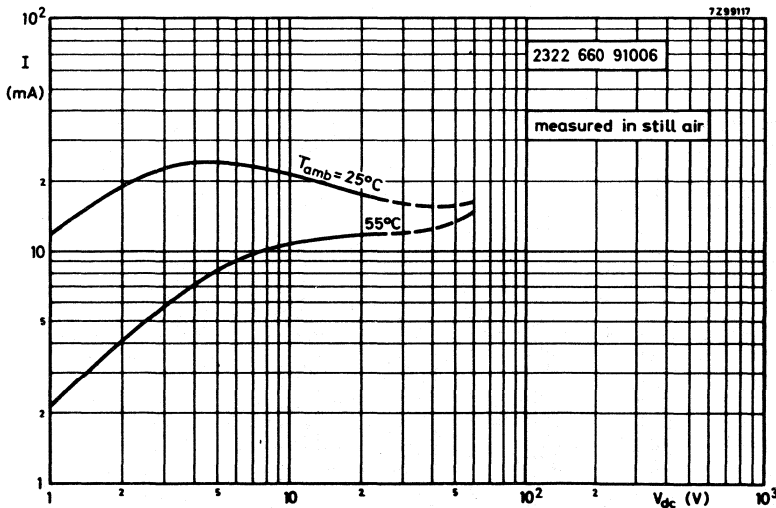

Fig. 2 Typical voltage/current characteristics.

\* Measuring voltage not exceeding 1,5 V(d.c.) to avoid internal heating.  
 \*\* Measurements made with specimen in phosphor bronze clips, in still air.  
 \*\*\* Type 2322 660 91009: -10 to +150 °C.

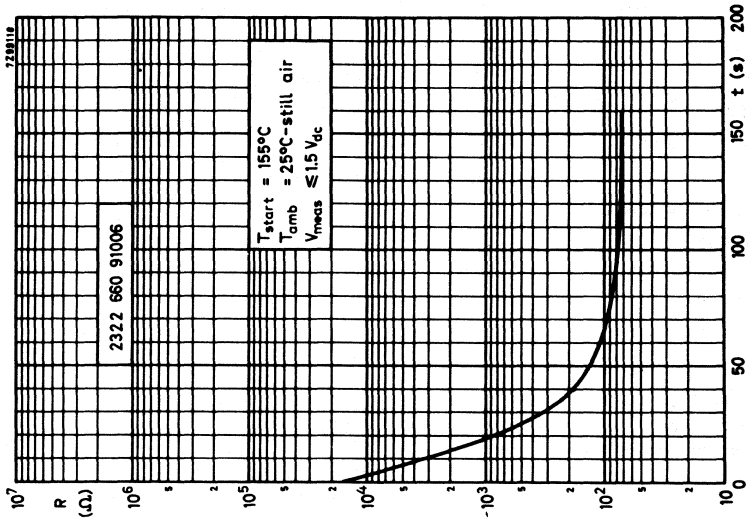

Fig. 4 Typical resistance/time (cooling) characteristic.

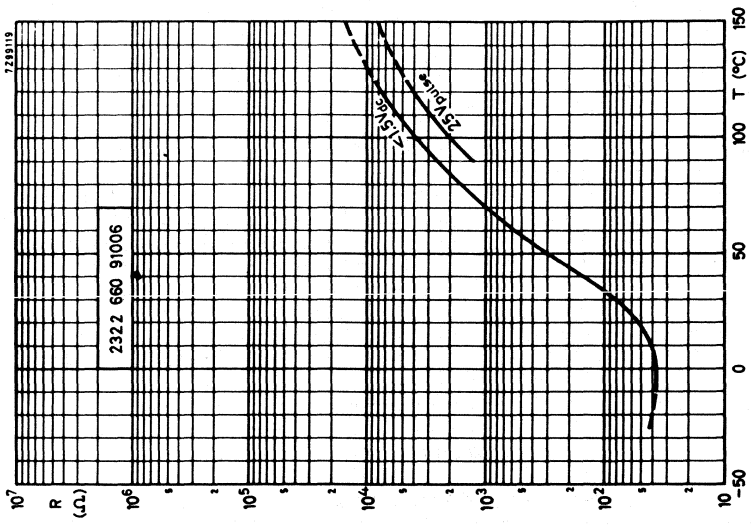

Fig. 3 Typical resistance/temperature characteristics.



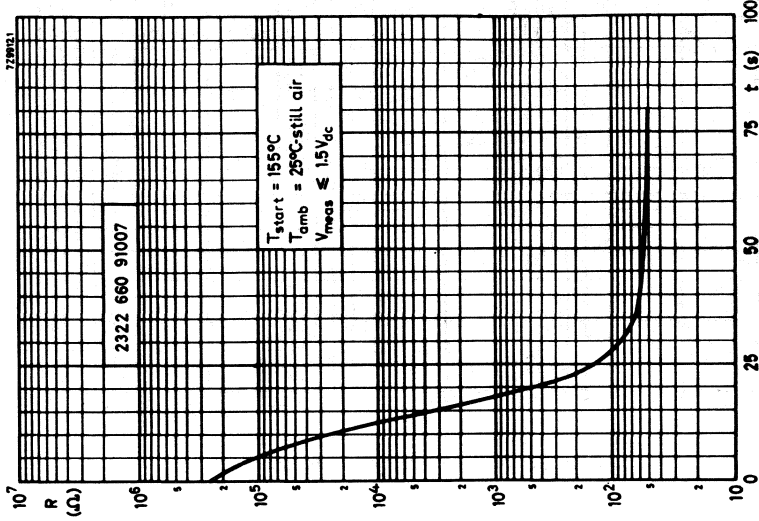

Fig. 6 Typical resistance/time (cooling) characteristic.

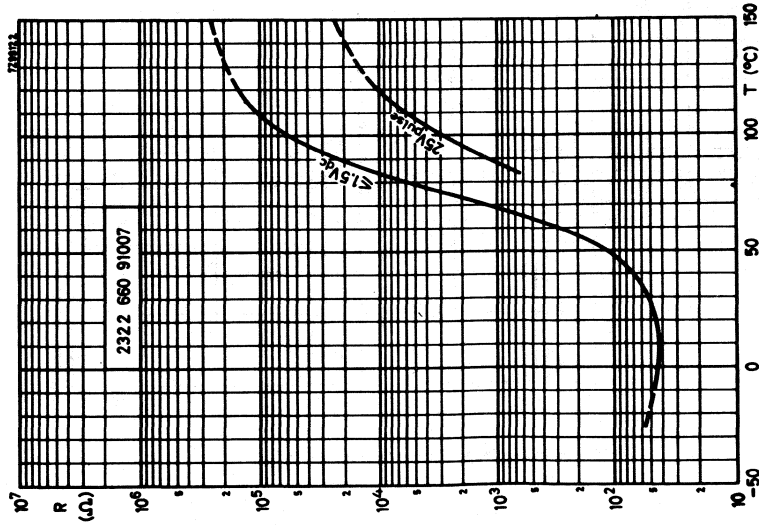

Fig. 5 Typical resistance/temperature characteristics.



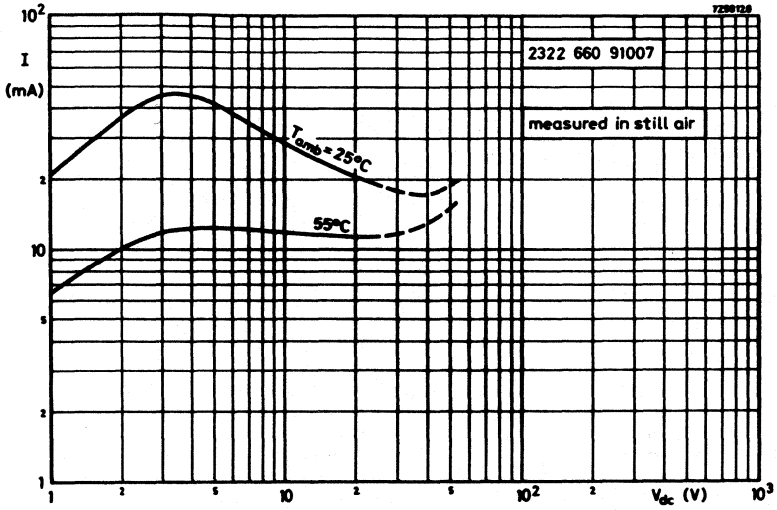

Fig. 7 Typical voltage/current characteristics.

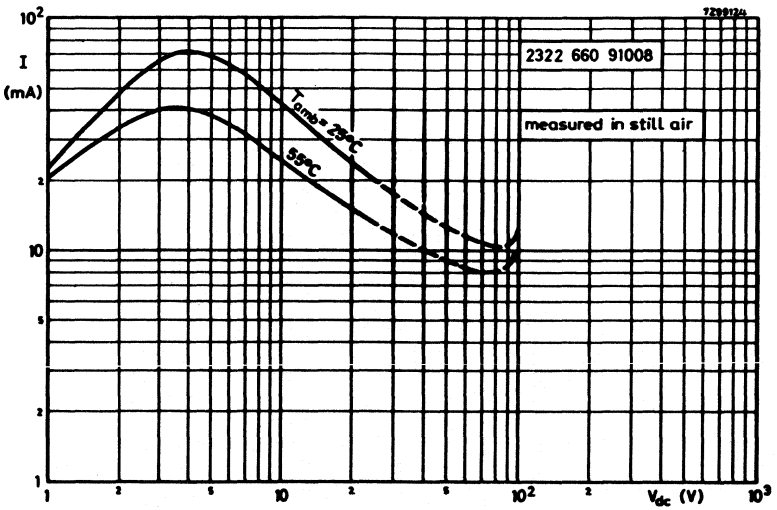

Fig. 8 Typical voltage/current characteristics.

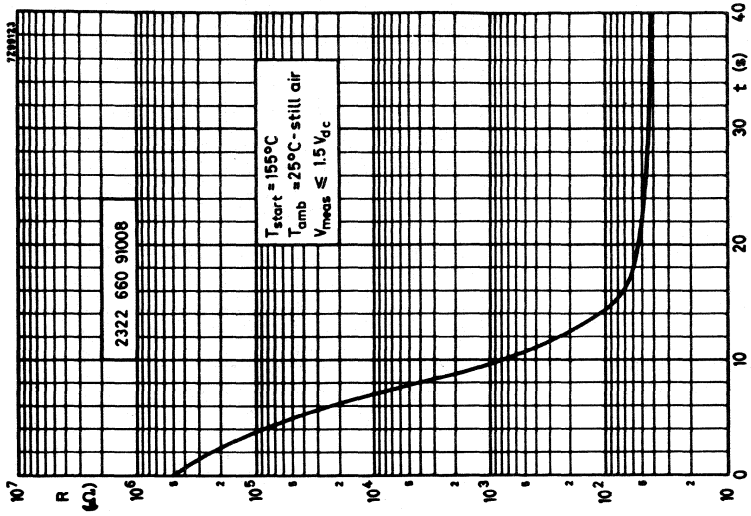

Fig. 10 Typical resistance/time (cooling) characteristic.

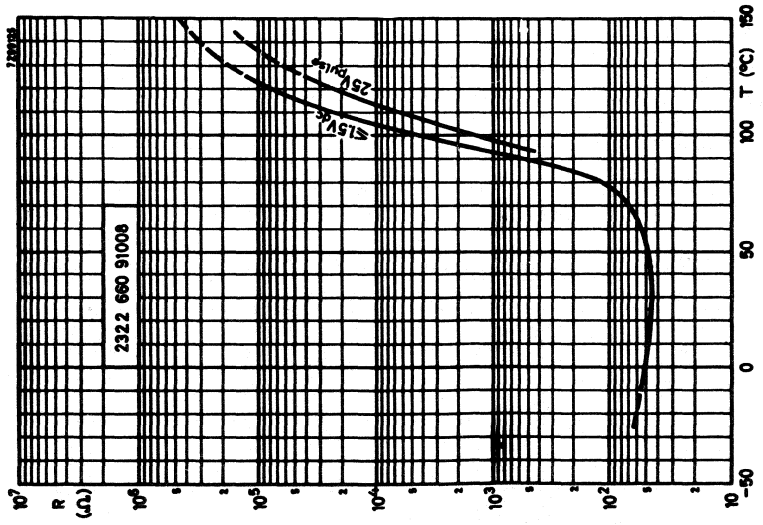

Fig. 9 Typical resistance/temperature characteristics.



2322 660 91006  
to  
2322 660 91009

Fig. 11 Typical resistance/  
temperature characteristic.

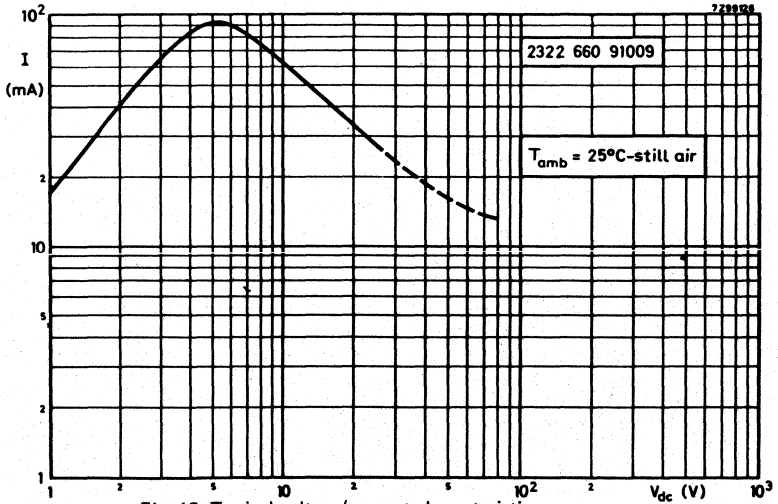
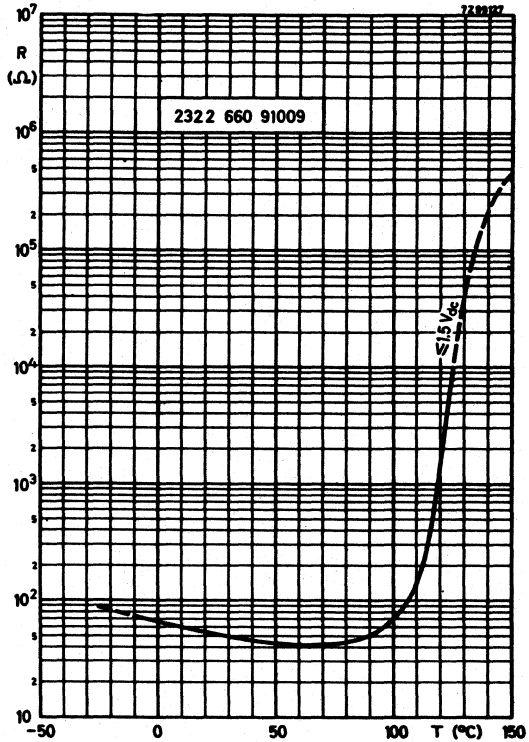

Fig. 12 Typical voltage/current characteristic.

## PTC THERMISTOR

disc

### QUICK REFERENCE DATA

Resistance value at +25 °C	750 to 1500 $\Omega$
Resistance value at +175 °C V <sub>pulse</sub> = 345 V	70 000 $\Omega$
Switch temperature	+115 °C
Temperature coefficient	+26%/K
Maximum voltage (r.m.s.)	245 V
Dissipation factor	7 mW/K
Operating temperature range at zero power	-25 to +155 °C
at maximum voltage	0 to +55 °C

### APPLICATION

General purpose.

### DESCRIPTION

The thermistor has a positive temperature coefficient. It consists of a disc with two tinned copper wires. The thermistor body is blue lacquered but not insulated.

### MECHANICAL DATA

#### Outlines

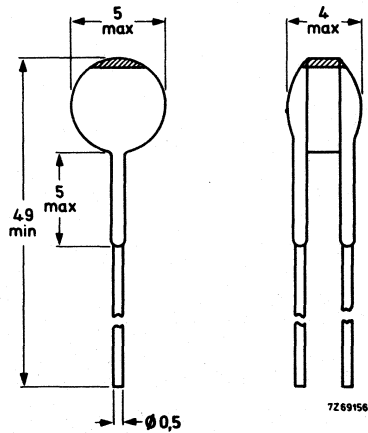

### PACKAGING

500 thermistors in a cardboard box.

<b>Marking</b>	Brown band on top, see Fig. 1.
<b>Mass</b>	0,4 g approximately
<b>Mounting</b>	In any position by soldering
<b>Robustness of terminations</b>	
Tensile strength	5 N
Bending	2,5 N
<b>Soldering</b>	
Solderability	max. 240 °C, max. 4 s
Resistance to heat	max. 265 °C, max. 11 s
<b>Impact</b>	1000 mm free fall
<b>Inflammability</b>	Uninflammable

**ELECTRICAL DATA**

Unless otherwise specified measured according to IEC draft publication 40 (secretariat) 288.

All values in the table without further indication are approximate values.

Resistance at +25 °C	750 to 1500 Ω
Resistance at +115 °C	max. 4000 Ω
Resistance at +175 °C and $V_{\text{pulse}} = 345 \text{ V}$	min. 70 000 Ω
Switch temperature	+115 °C
Temperature coefficient	+28%/K
Dissipation factor	7 mW/K
Heat capacity of ceramic only	0,125 J/K 0,08 J/K
Thermal time constant	17,5 s
Operating temperature range at zero power	-25 to +155 °C
at maximum voltage	0 to +55 °C
Voltage dependence at +155 °C	0,35
Balance voltage d.c.	90 V
Maximum voltage (r.m.s.)	245 V

\* Measurement made without internal heating occurring.



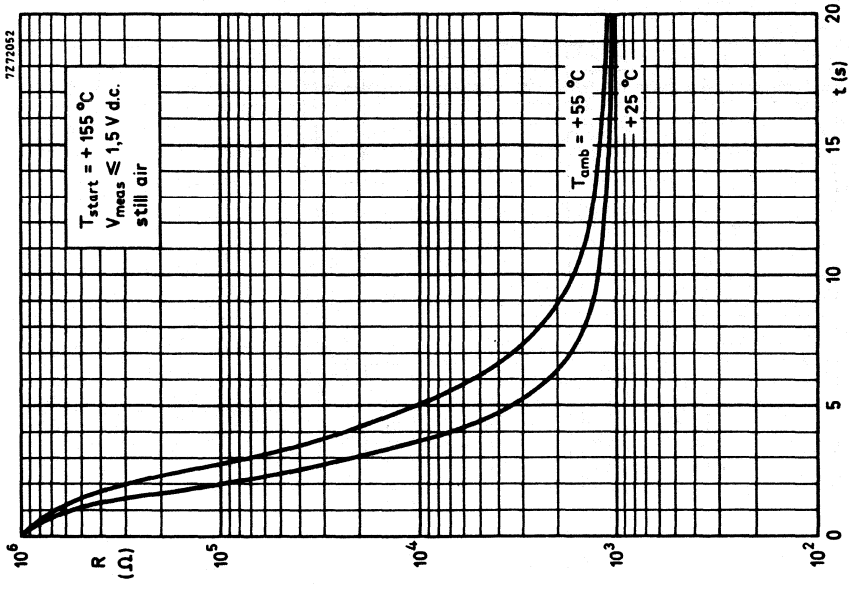

Fig. 3 Typical resistance/time (cooling) characteristics.

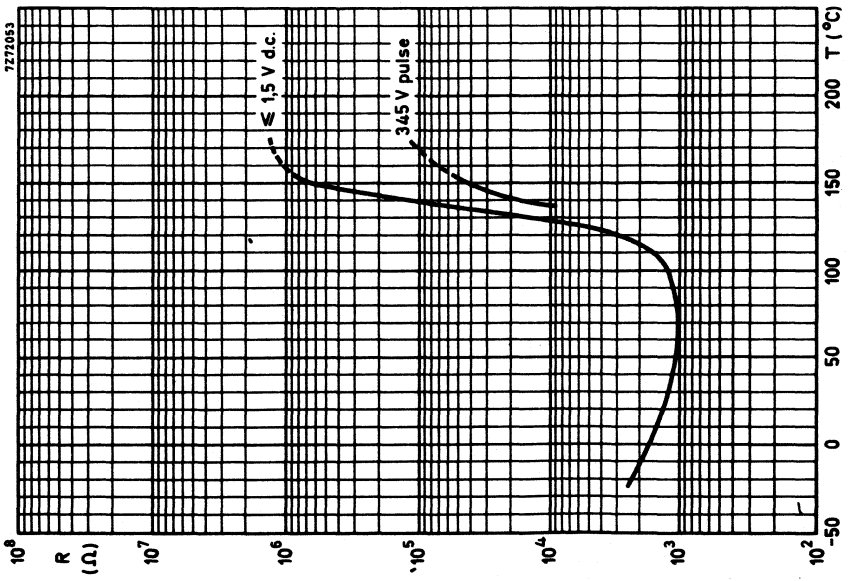

Fig. 2 Typical resistance/temperature characteristics.



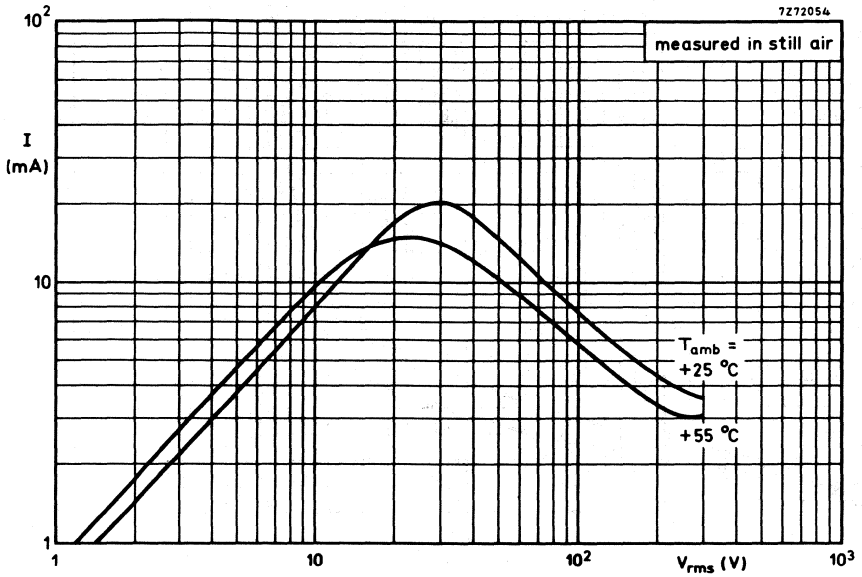

Fig. 4 Typical voltage/current characteristics.



## PTC THERMISTORS

disc

### QUICK REFERENCE DATA

Resistance value at +25 °C	30 to 50 Ω
Operating temperature range at zero power at $V_{max}$	-10 to +125 °C 0 to +55 °C

### APPLICATION

General purpose.

### DESCRIPTION

The thermistors have a positive temperature coefficient. They consist of a disc with two tinned copper wires. The thermistor body is blue lacquered but not insulated.

### MECHANICAL DATA

#### Outlines

Table 1

catalogue number	colour band	$H_{max}$
2322 661 91002	yellow	6
2322 661 91003	green	6
2322 661 91004	orange	6
2322 661 91005	red	5

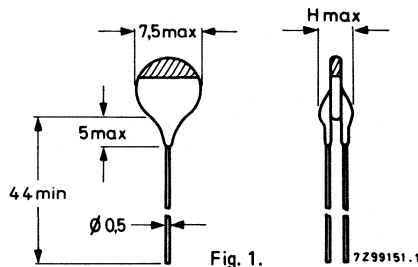

Fig. 1.

### Marking

The thermistors are marked with a colour band at the top of the body according to Fig. 1.

**Mass** 1 g approximately

**Mounting** In any position by soldering

### Robustness of terminations

Tensile strength 10 N  
Bending 5 N

### Soldering

Solderability max. 240 °C, 4 s  
Resistance to heat max. 240 °C, 4 s

### PACKAGING

500 thermistors in a cardboard box.

**ELECTRICAL DATA**

Table 2, typical values except R and  $V_{max}$

	catalogue number 2322 661 followed by				
	91002	91003	91004	91005	
Resistance					
at 25 °C *	50	40	30	50	Ω
at 40 °C			< 90		Ω
at 60 °C	< 100				Ω
at 95 °C **		< 80			Ω
at 100 °C	> 1		> 10	3 to 20	kΩ
at 130 °C		> 10			kΩ
Dissipation factor ***	8,5	8,5	8,5	6	mW/K
Maximum voltage (d.c.)	50	50	50	40	V
Switch temperature	80	110	45	25	°C
Temperature coefficient	18	75	16	9	%/K
Heat capacity ***	0,425	0,425	0,425	0,240	J/K
Thermal time constant ***	50	50	50	40	s
Voltage dependence β	0,48	0,28	0,25	0,35	
Balance voltage (d.c.)	110	25	65	25	V
Tolerance on R <sub>25</sub>	± 15 Ω				
Operating temperature range					
at zero power	-10 to +125 °C				
at V <sub>max</sub>	0 to +55 °C				

\* Measuring voltage not exceeding 1,5 V (d.c.) to avoid internal heating.  
 \*\* Measured without internal heating.  
 \*\*\* Measured with phosphor-bronze clips, in still air.

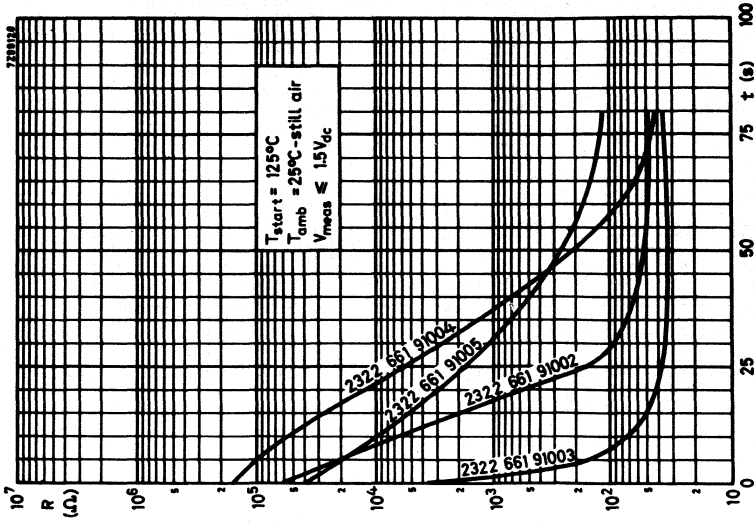

Fig. 3 Typical resistance/time (cooling) characteristics.

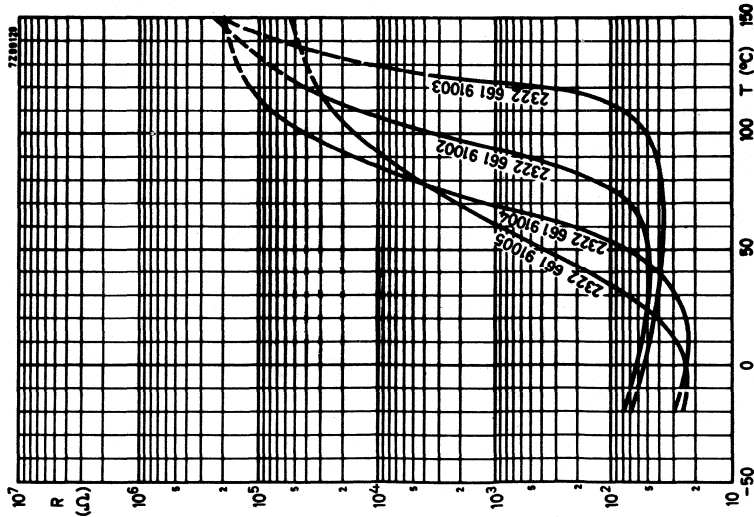

Fig. 2 Typical resistance/temperature characteristics.



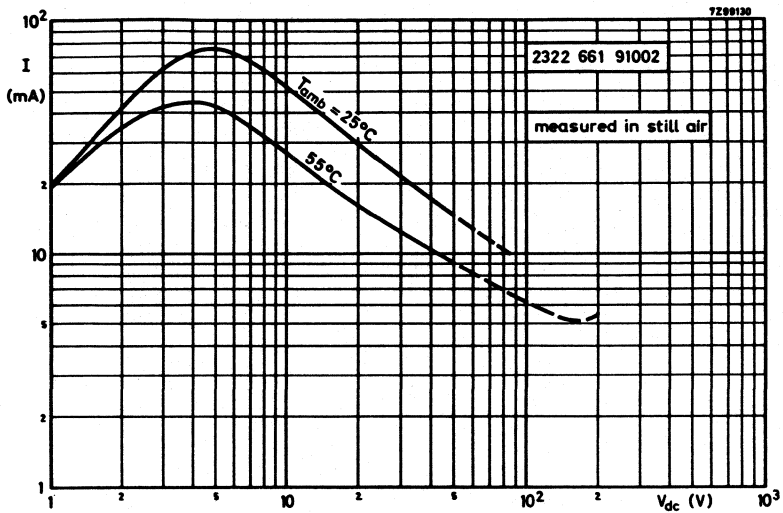

Fig. 4 Voltage/current characteristics.

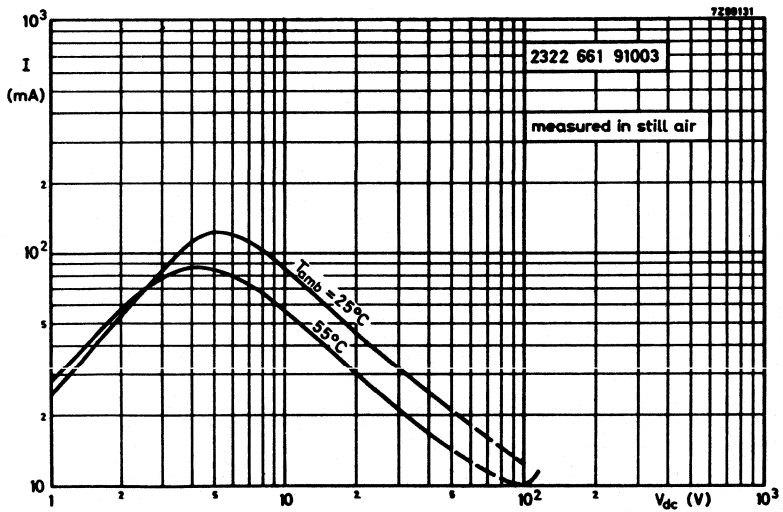

Fig. 5 Voltage/current characteristics.

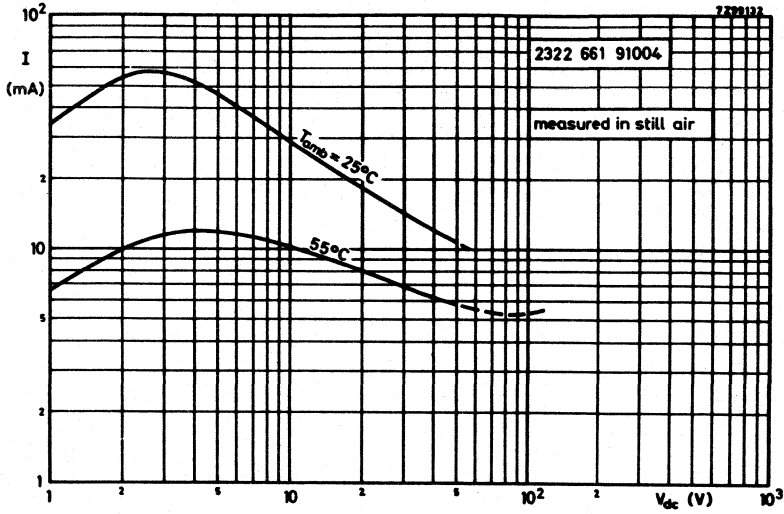

Fig. 6 Voltage/current characteristics.

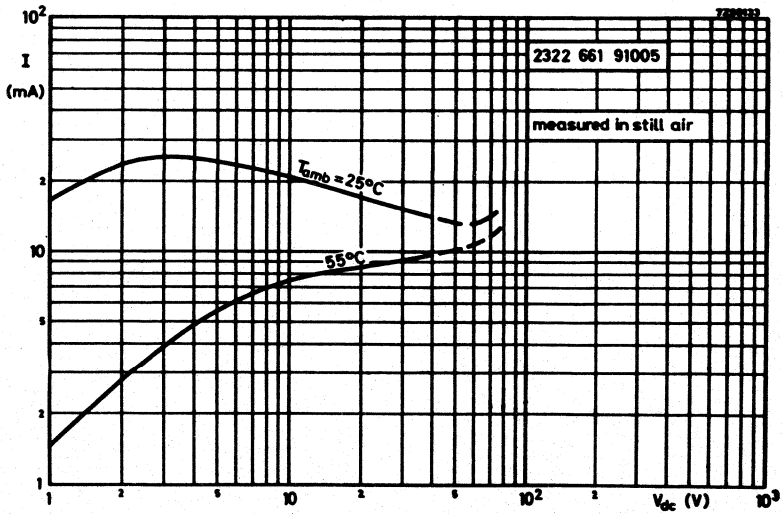

Fig. 7 Voltage/current characteristics.

## PTC THERMISTOR

disc

### QUICK REFERENCE DATA

Resistance value at +25 °C	36 to 50 Ω
Resistance value at +165 °C $V_{\text{pulse}} = 180 \text{ V}$	> 20 kΩ
Switch temperature	~ +115 °C
Temperature coefficient	~ 35%/K
Maximum voltage (d.c.)	180 V
Dissipation factor	~ 13 mW/K
Operating temperature range at zero power	0 to +155 °C
at maximum voltage (d.c.)	0 to +55 °C

### APPLICATION

Protection of telegraphy relay contacts.

### DESCRIPTION

The thermistor has a positive temperature coefficient. It consists of a disc with two tinned brass wires. The thermistor body is blue lacquered but not insulated.

### MECHANICAL DATA

#### Outlines

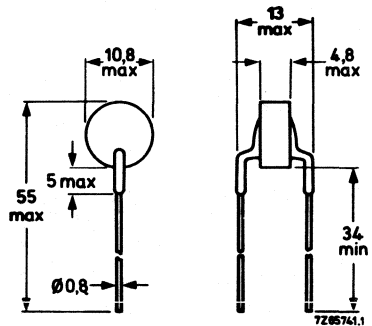

Fig. 1.

<b>Mass</b>	0,5 g approximately
<b>Mounting</b>	In any position by soldering

### PACKAGING

→ 100 thermistors in a cardboard box.



**ELECTRICAL DATA**

Resistance	
at +25 °C ( $T_{ref}$ )*	36 to 50 $\Omega$
at +115 °C*	< 120 $\Omega$
at +165 °C, $V_{pulse} = 180 V^{**}$	> 20 k $\Omega$
Current at +25 °C, $V_{dc} = 180 V$ continuously ***	< 10 mA
Switch temperature	~ +115 °C
Temperature coefficient	~ 35%/K
Dissipation factor ***	~ 13 mW/K
Heat capacity ***	1 J/K
Thermal time constant ***	~ 80 s
Operating temperature range	
at zero power	0 to +155 °C
at $V_{max}$	0 to +55 °C
Voltage dependence $\beta$ at +150 °C	~ 0,3
Balance voltage (d.c.)	~ 105 V
Maximum voltage (d.c.) at +55 °C	180 V

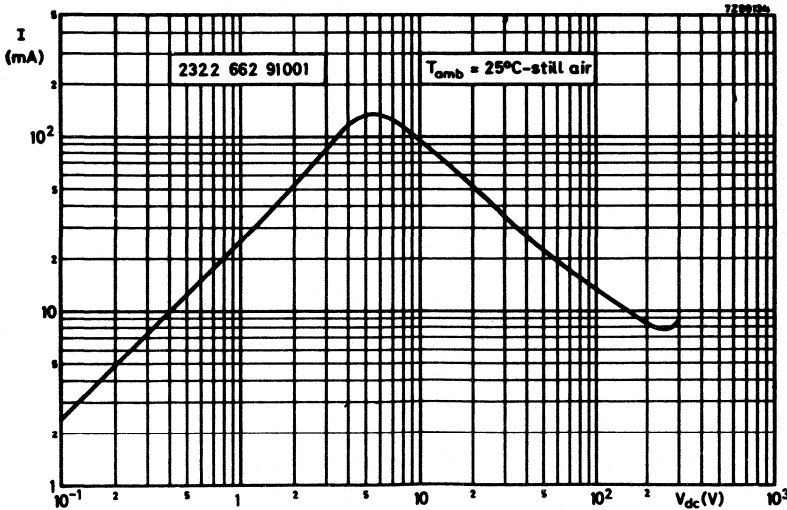

Fig. 2 Typical voltage/current characteristic.

- \* Measuring voltage not exceeding 1,5 V(d.c.) to avoid internal heating.
- \*\* Measurement made without internal heating occurring.
- \*\*\* Measurement made with specimen in phosphor bronze clips, in still air.

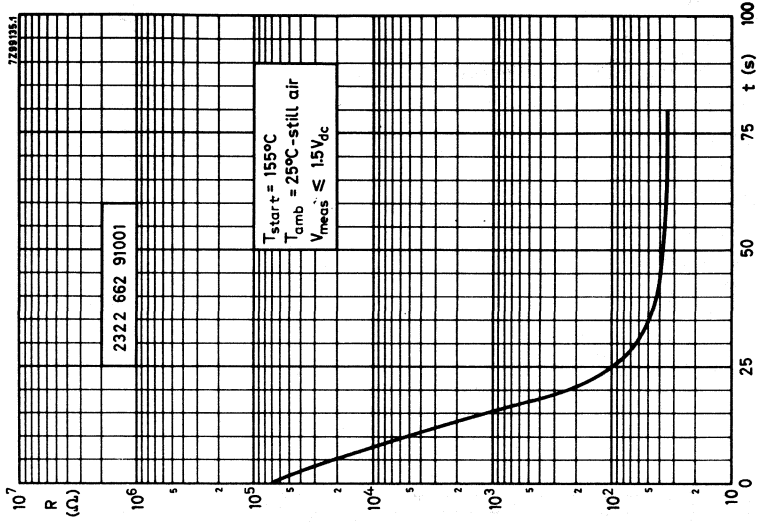

Fig. 4 Typical resistance/time (cooling) characteristic.

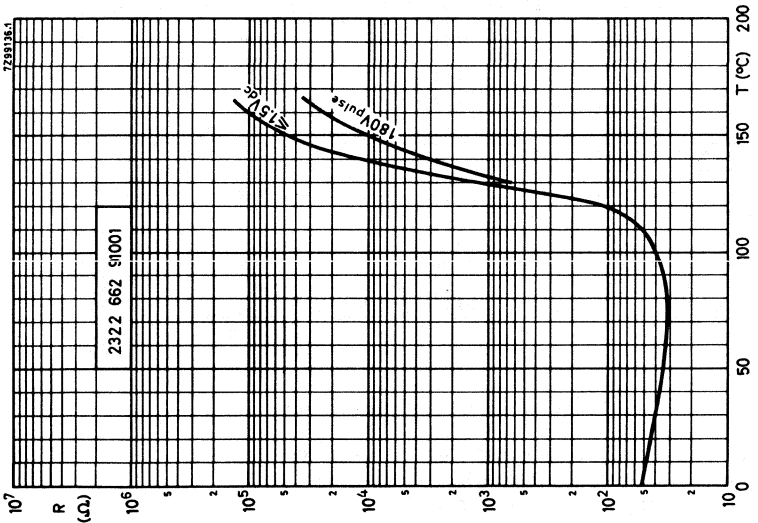

Fig. 3 Typical resistance/temperature characteristics.

## PTC THERMISTOR

disc

### QUICK REFERENCE DATA

Resistance value at +25 °C	max. 1,1 $\Omega$
Resistance value at +55 °C	max. 1 $\Omega$
Switch temperature	+100 °C
Temperature coefficient	+6%/K
Maximum r.m.s. voltage	18 V
Operating temperature range	
at zero power	-25 to +155 °C
at maximum voltage	0 to +55 °C

### APPLICATION

Overload protection of loudspeakers.

### DESCRIPTION

The thermistor has a positive temperature coefficient. It consists of a disc with two tinned brass wires.

### MECHANICAL DATA

#### Outlines

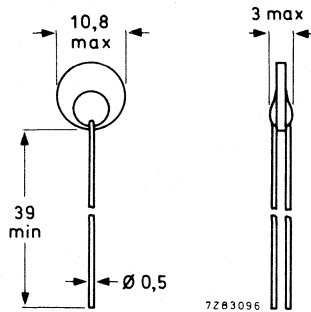

Fig. 1.

#### Marking

None

#### Mass

0,55 g approximately

#### Mounting

In any position by soldering

#### Soldering

##### Solderability

max. 240 °C, max. 4 s

##### Resistance to heat

max. 265 °C, max. 11 s

#### Impact

0,2 m free fall

#### Inflammability

Uninflammable

**ELECTRICAL DATA**

All values in the table without further indication are approximate values

Resistance at +25 °C	max. 1,1 Ω
Resistance at +115 °C	max. 1 Ω
Switch temperature	+100 °C
Switching current at $T_{amb} = +25 °C$	max. 710 mA
Max. current at which no switching occurs at $T_{amb} = +25 °C$	570 mA
Temperature coefficient	+6%/K
Maximum r.m.s. voltage	18 V
Response time at $I = 1,3 A$ and $T_{amb} = +25 °C$	max. 20 s
Steady state current at 18 V r.m.s. and $T_{amb} = +25 °C$	max. 95 mA
Operating temperature range at zero power	-25 to +155 °C
at maximum voltage	0 to +55 °C

**PACKAGING**

→ 250 thermistors in a cardboard box.

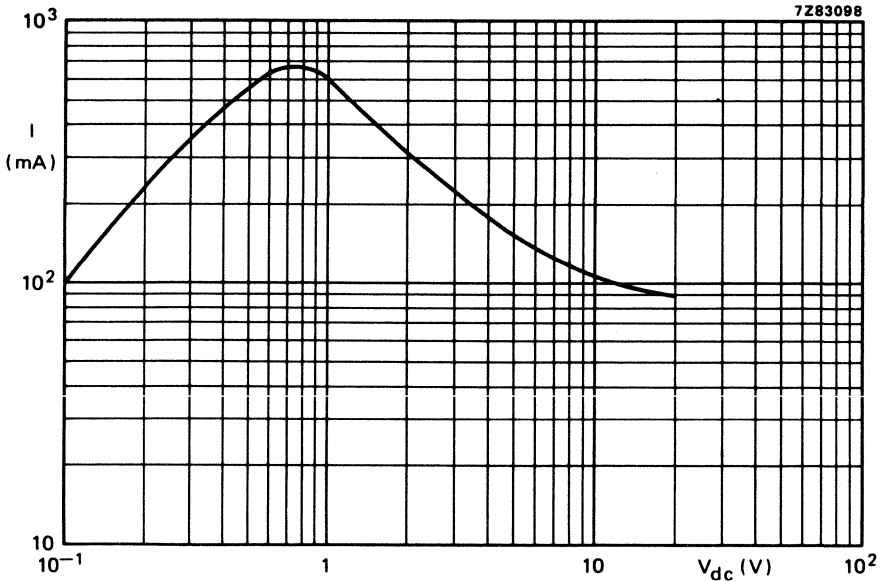

Fig. 2 Typical current/voltage characteristic.

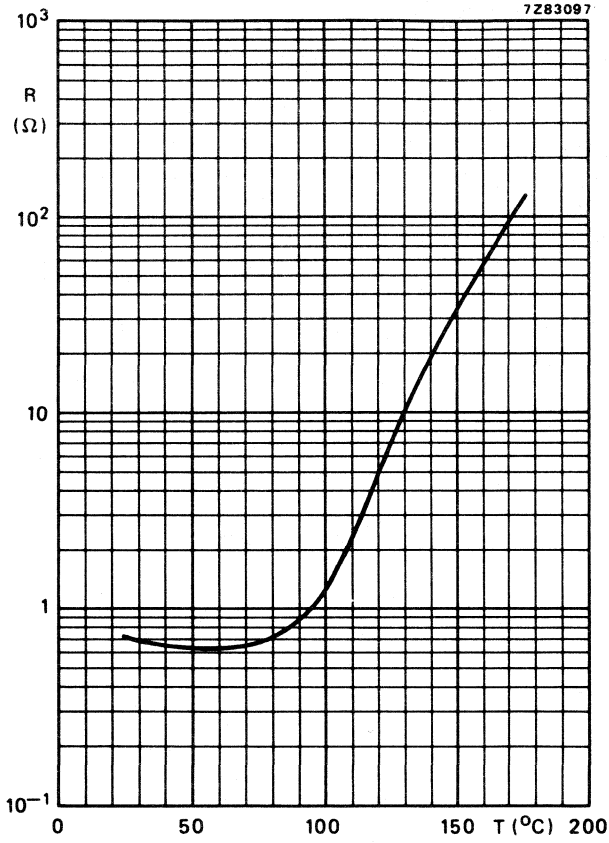

Fig. 3 Typical resistance/temperature characteristic.



## PTC THERMISTOR

disc

### QUICK REFERENCE DATA

Resistance value at +25 °C	70 to 100 Ω
Max. current at 600 V r.m.s. and +25 °C	5 mA
Switch temperature	+120 °C
Temperature coefficient	+35%/K
Maximum r.m.s. voltage	460 V
Dissipation factor	11,5 mW/K
Operating temperature range at zero power	-25 to +175 °C
at maximum voltage	0 to +85 °C

### APPLICATION

Suitable in all kinds of applications, e.g. fluorescent lamp starter.

### DESCRIPTION

This thermistor has a positive temperature coefficient. It is a leadless disc which is neither lacquered nor insulated.

### MECHANICAL DATA

#### Outlines

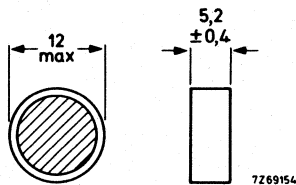

Fig. 1.

#### Marking

None

#### Mass

2,7 g approximately

#### Mounting

In any position by clamping

#### Impact

100 mm free fall

#### Inflammability

Uninflammable

### → PACKAGING

Plastic blister pack containing 192 items.

**ELECTRICAL DATA**

All values in this table without further indication are approximate values.

Resistance at +25 °C	70 to 100 $\Omega$
Resistance at +100 °C	max. 200 $\Omega$
Max. current at 600 V r.m.s. and +25 °C (measurement made without internal heating)	5 mA
Switch temperature	+120 °C
Temperature coefficient	+35%/K
Dissipation factor	11,5 mW/K
Heat capacity	1,3 J/K
Thermal time constant	115 s
Operating temperature range	
at zero power	-25 to +175 °C
at maximum voltage	0 to +85 °C
Voltage dependence at +175 °C	0,22
Balance voltage	230 V
Maximum r.m.s. voltage, with series resistor of 300 $\Omega$	460 V

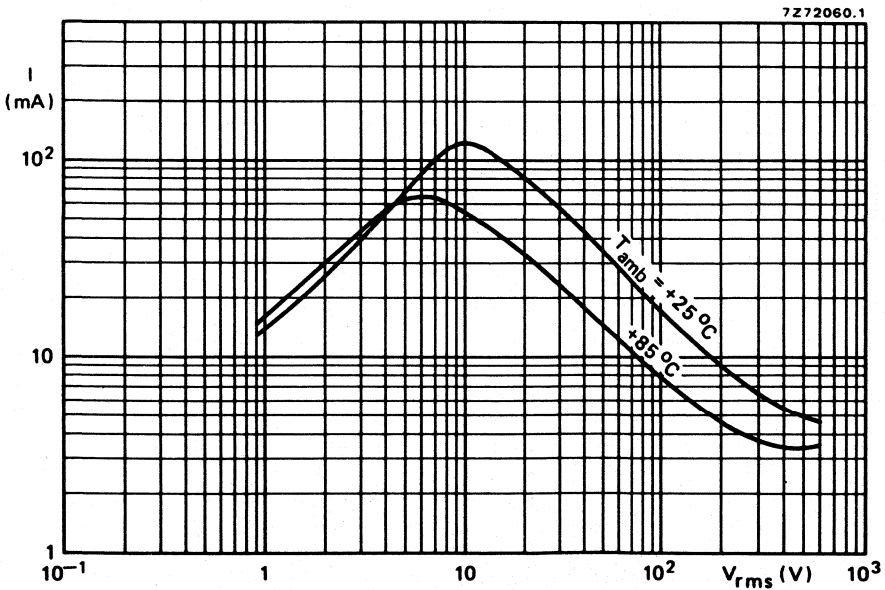

Fig. 2 Typical voltage/current characteristics.

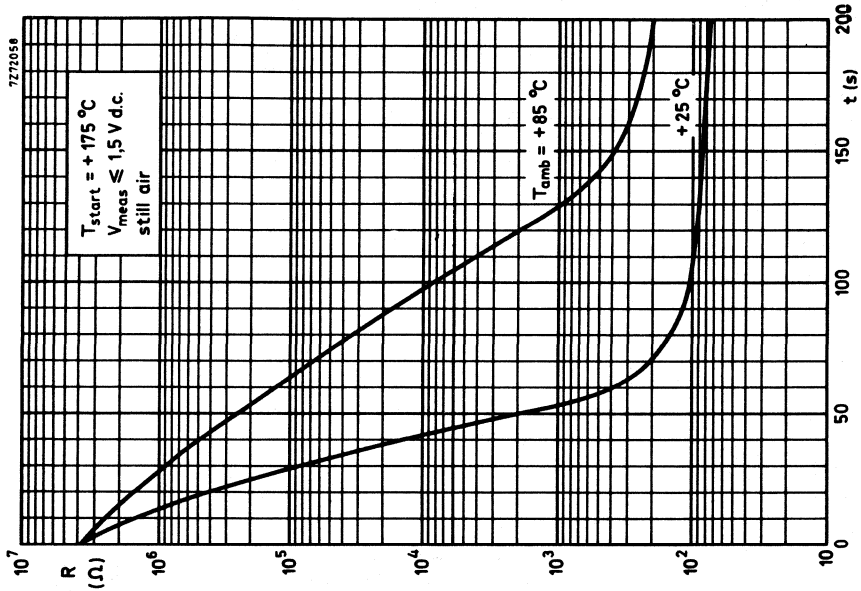

Fig. 3 Typical resistance/time (cooling) characteristics.

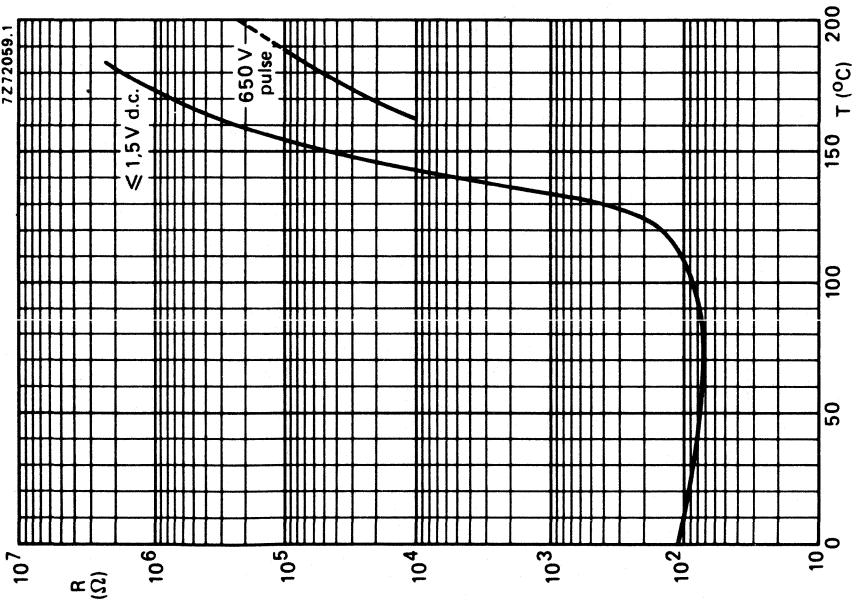

Fig. 2 Typical resistance/temperature characteristics.



## PTC THERMISTOR

disc

### QUICK REFERENCE DATA

Resistance value	
at +25 °C	45 to 60 $\Omega$
at +150 °C	> 45 k $\Omega$
$V_{\text{pulse}} = 340 \text{ V}$	
Switch temperature	~ +75 °C
Temperature coefficient	~ +20%/K
Max. r.m.s. voltage at $T_{\text{amb}} \leq 60 \text{ °C}$	265 V
Dissipation factor	~ 20 mW/K
Operating temperature range	
at zero power	-25 to +155 °C
at $V_{\text{max}}$	0 to +60 °C

### APPLICATION

In degaussing circuits of colour television sets.

### DESCRIPTION

This thermistor has a positive temperature coefficient. It is a disc with two tinned copper wires. The thermistor body is blue lacquered, but not insulated.

### MECHANICAL DATA

#### Outlines

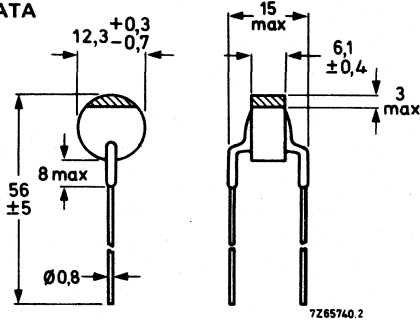

Fig. 1.

Marking	Green colour band on top of the body.
Mass	4,2 g approximately.
Mounting	In any position by soldering. Soldering should be done at least 15 mm from the thermistor body.

### PACKAGING

100 thermistors in a cardboard box.

**ELECTRICAL DATA**

Resistance	
at +25 °C *	45 to 60 Ω
at +75 °C *	< 160 Ω
at +150 °C, $V_{pulse} = 340 V$ **	> 45 kΩ
Switch temperature	~ +75 °C
Temperature coefficient	~ +20%/K
Dissipation factor ***	~ 20 mW/K
Heat capacity ***	~ 2,2 J/K
Thermal time constant ***	~ 110 s
Operating temperature range	
at zero power	-25 to +155 °C
at $V_{max}$	0 to +60 °C
Voltage dependence $\beta$ at +155 °C	~ 0,29
Balance voltage (d.c.)	~ 200 V
Maximum r.m.s. voltage, with series resistor of 33 Ω	265 V

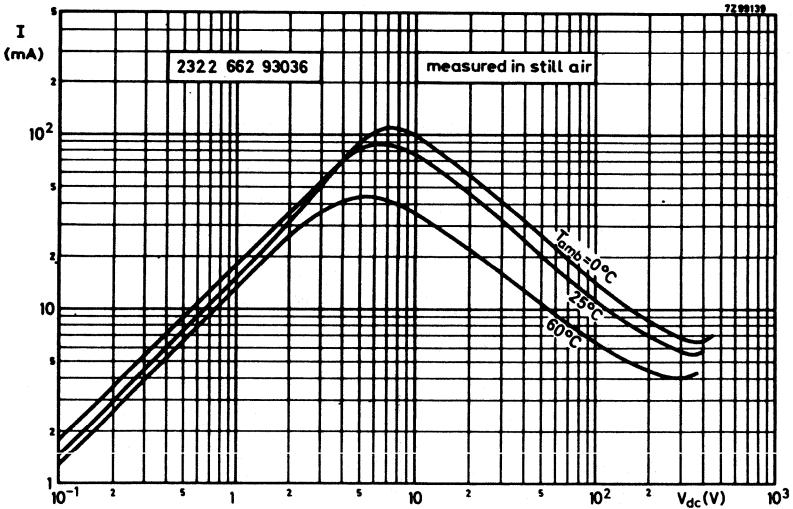

Fig. 2 Typical voltage/current characteristics.

\* Measuring voltage not exceeding 1,5 V(d.c.) to avoid internal heating.  
 \*\* Measurement made without internal heating.  
 \*\*\* Measurement made with specimen in phosphor bronze clips, in still air.

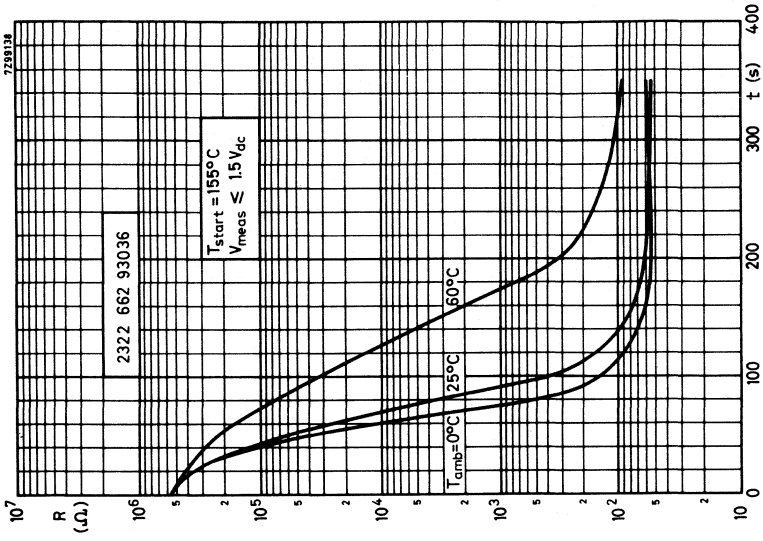

Fig. 4 Typical resistance/time (cooling) characteristics.

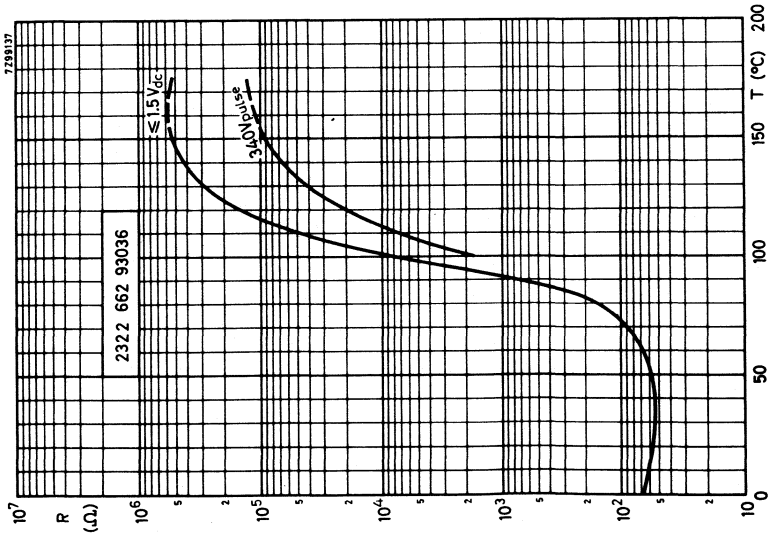

Fig. 3 Typical resistance/temperature characteristics (no internal heating).





## PTC THERMISTOR

disc

### QUICK REFERENCE DATA

Resistance	
at +25 °C	100 Ω ± 20%
at +155 °C	
V <sub>pulse</sub> = 380 V	≥ 40 kΩ
Switch temperature	75 °C
Maximum r.m.s. voltage	265 V
Dissipation factor	~ 15 mW/K
Operating temperature range	
at zero power	-25 to +155 °C
at V <sub>max</sub>	0 to +60 °C

### APPLICATION

In degaussing circuits of colour television sets.

### DESCRIPTION

This thermistor has a positive temperature coefficient. It consists of a disc with two tinned brass wires. The thermistor body is not lacquered.

### MECHANICAL DATA

#### Outlines

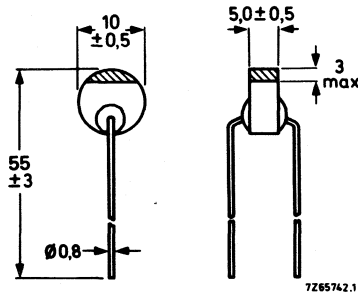

Fig. 1.

<b>Marking</b>	The thermistor is marked with a red colour band on top of the body.
<b>Mass</b>	2,7 g approx.
<b>Mounting</b>	In any position by soldering at min 15 mm from the body.

**Robustness of terminations**

Tensile strength	20 N
Bending	10 N

**Soldering**

Solderability	max. 240 °C, max. 4 s
Resistance to heat	max. 240 °C, max. 4 s

**PACKAGING**

100 thermistors in a cardboard box.

**ELECTRICAL DATA**

All values in the table without further indication are approximate values.

Resistance value	
at +25 °C *	100 Ω ± 20%
at +72 °C *	< 2 × R <sub>25</sub>
at +85 °C *	> 2 × R <sub>25</sub>
at +155 °C and V <sub>pulse</sub> = 380 V **	≥ 40 kΩ
Switch temperature	+75 °C
Temperature coefficient	+35%/K
Maximum r.m.s. voltage, with series resistor of 33 Ω	265 V
Dissipation factor ***	15,3 mW/K
Thermal time constant ***	80 s
Heat capacity of complete thermistor ***	1,2 J/K
Balance voltage (d.c.)	190 V
Voltage dependence at 155 °C	0,26
Operating temperature range	
at zero power	-25 to +155 °C
at maximum voltage	0 to +60 °C

\* Measuring voltage not exceeding 1,5 V d.c. to avoid internal heating.

\*\* Measurement made without internal heating.

\*\*\* Measurement made with specimen in phosphor bronze clips, in still air.

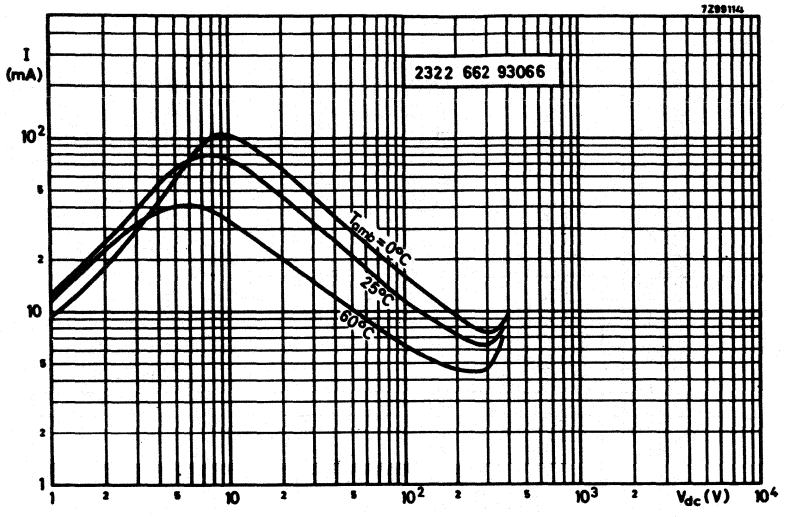

Fig. 3 Typical voltage/current characteristics.

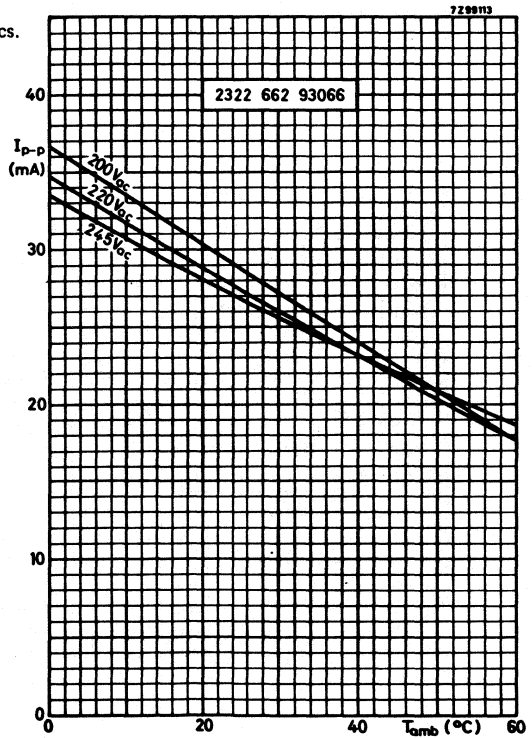

Fig. 4 Typical characteristics of peak to peak current against the ambient temperature at different voltages.

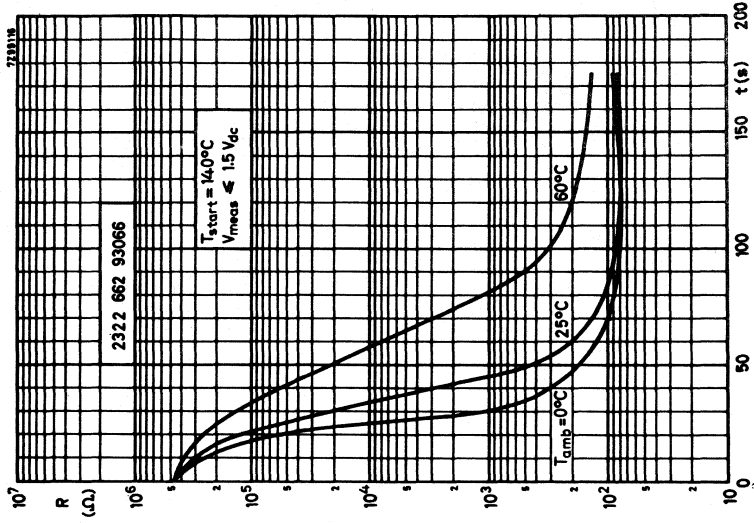

Fig. 6 Typical resistance/time (cooling) characteristics.

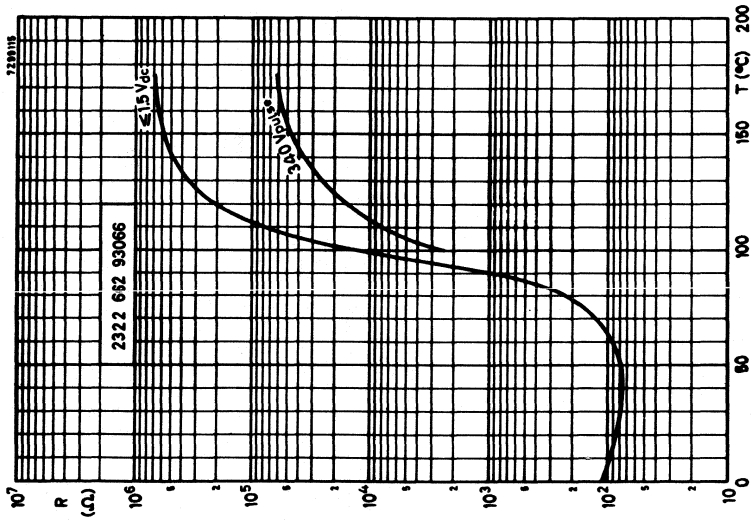

Fig. 5 Typical resistance/temperature characteristics.





## DUAL PTC THERMISTORS

### QUICK REFERENCE DATA

	2322 662 98001	2322 662 98003
R.M.S. current through the coil measured at	200 V	220 V
min. inrush peak current	5 A	5 A
max. idle peak current		
after 5 s	70 mA	70 mA
after 30 s	5 mA	5 mA
after 3 min	2 mA	2 mA
Maximum r.m.s. voltage	245 V	265 V
Switch temperature	75 °C	
Operating temperature range		
at zero power	-25 to +155 °C	
at maximum voltage	0 to +60 °C	

### APPLICATION

In degaussing circuits of colour television sets.

### DESCRIPTION

The thermistor consists of two disc PTC thermistors clamped between spring contacts. This assembly ensures a good thermal contact between both discs, which is essential for function of this device. The thermistor is enclosed in a plastic housing. The three connecting pins are arranged to fit a printed-wiring board with an 0,1 inch grid.

### MECHANICAL DATA

#### Outlines

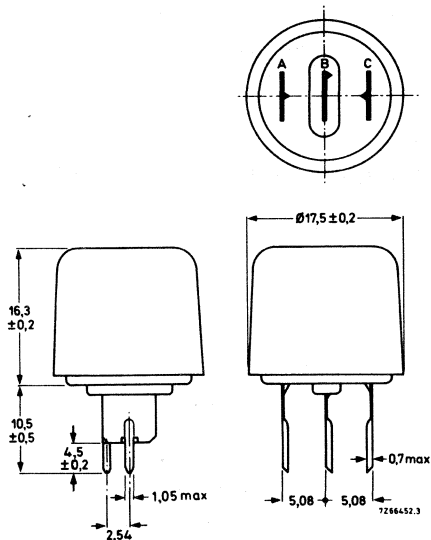

A is to be connected to the mains;  
C is to be connected to the degaussing coil.

Fig. 1.

2322 662 98001  
2322 662 98003

<b>Marking</b>	The catalogue number is moulded in the top of the cap
<b>Mass</b>	7,3 g approximately
<b>Mounting</b>	In any position by soldering
<b>Robustness of terminations</b>	
Tensile strength	20 N
<b>Soldering</b>	
Solderability	max. 240 °C, max. 4 s
Resistance to heat	max. 265 °C, max. 11 s
<b>Impact</b>	
Free fall	1000 mm

**PACKAGING**

→ 500 thermistors in a cardboard box.

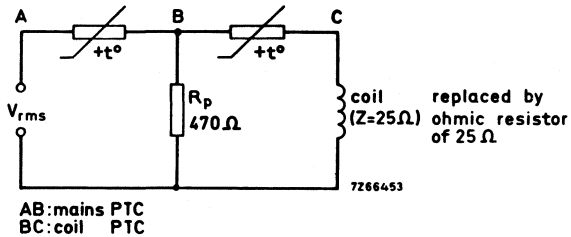

Fig. 2 Measuring circuit.  $R_p$  must be able to withstand a peak power of 25 W for 300 ms.

## ELECTRICAL DATA

	2322 662 98001	2322 662 98003
R.M.S. current through the coil measured in circuit of Fig. 2 at min. inrush current	200	220 V
max. idle peak current after 5 s	5	5 A
after 30 s	70	70 mA
after 3 min	5	5 mA
	2	2 mA
Resistance at +25 °C:		
of mains PTC *	~ 25	~ 30 Ω
of coil PTC *	~ 8	~ 8 Ω
at T <sub>amb</sub> = +175 °C and 345 V pulsed: of mains PTC**	≥ 32	≥ 35 kΩ
at T <sub>amb</sub> = +155 °C: of coil PTC	≥ 20	≥ 20 kΩ
Switch temperature of mains and coil PTC	75	75 °C
Temperature coefficient		
of mains PTC	~ 23	~ 25 %/K
of coil PTC	~ 25	~ 25 %/K
Balance voltage (d.c.) of mains PTC	~ 190	~ 160 V
Voltage dependency at +155 °C of mains PTC	~ 0,28	~ 0,26
Maximum r.m.s. voltage in circuit ***	245	265 V
Dissipation factor ***	~ 13,5	~ 13,5 mW/K
Thermal time constant ***	~ 200	~ 200 s
Heat capacity of ceramic		
of mains PTC	~ 1,6	~ 1,6 J/K
of coil PTC	~ 0,47	~ 0,43 J/K
of complete assembly ***	~ 2,7	~ 2,7 J/K
Operating temperature range		
at zero power	-25 to +155	-25 to +155 °C
at maximum voltage	0 to +60	0 to +60 °C

\* Measuring voltage not exceeding 1,5 V d.c. to avoid internal heating.

\*\* Measured without self heating.

\*\*\* In still air, the thermistor soldered on printed-wiring board.

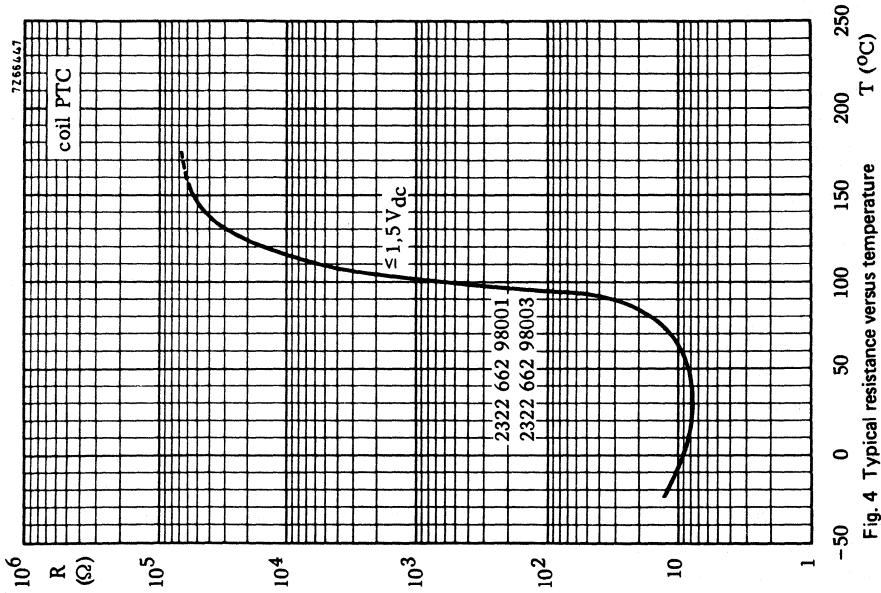

Fig. 4 Typical resistance versus temperature characteristics of the coil PTC thermistor.

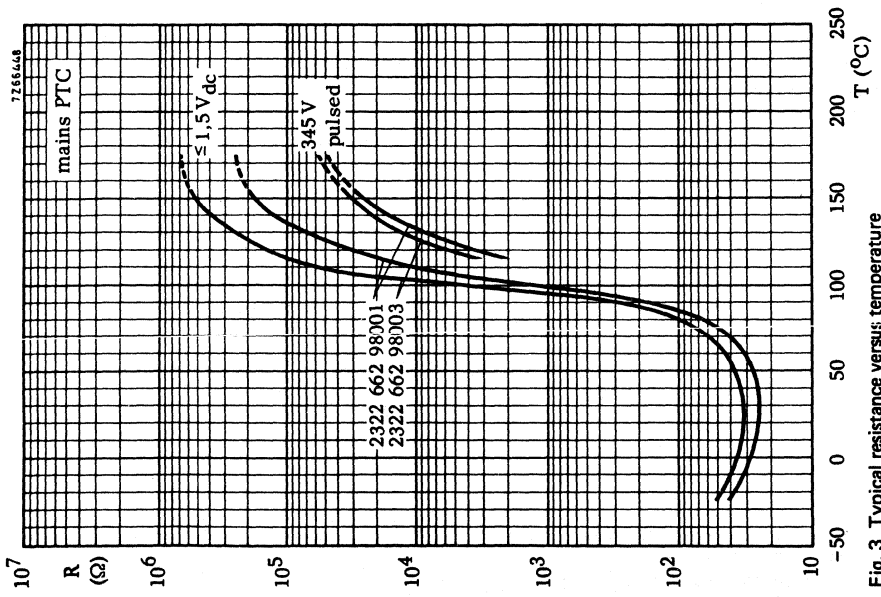

Fig. 3 Typical resistance versus temperature characteristics of the mains PTC thermistor.

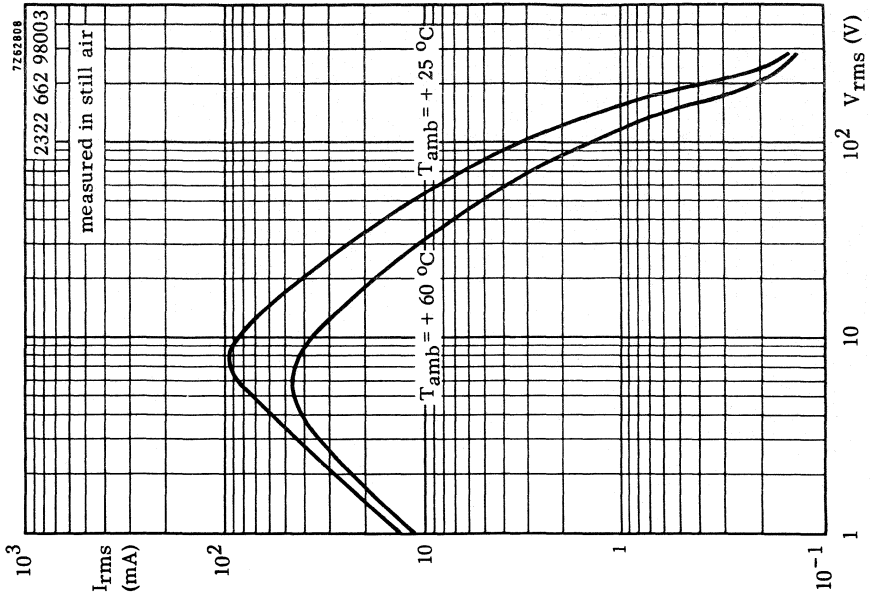

Fig. 6 Typical static current through the coil versus voltage characteristics.

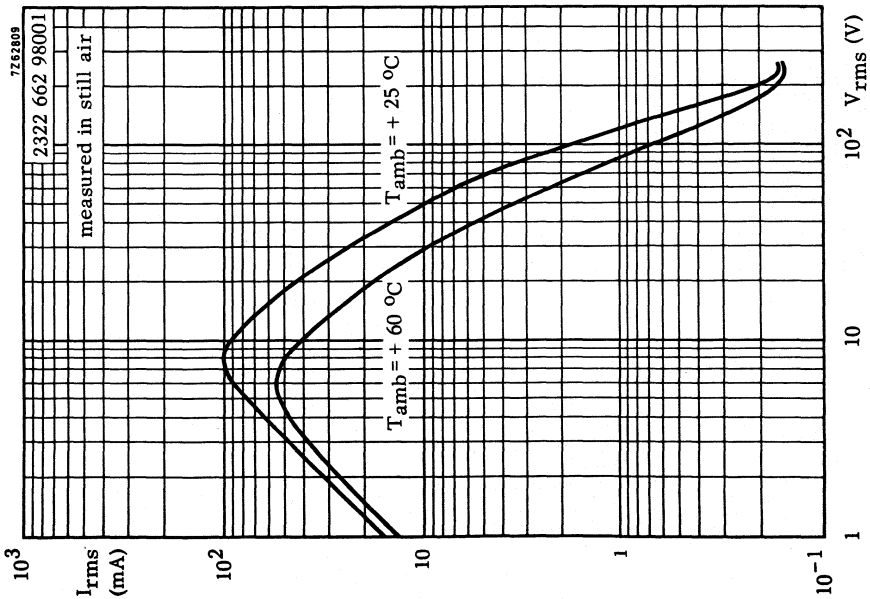

Fig. 5 Typical static current through the coil versus voltage characteristics.



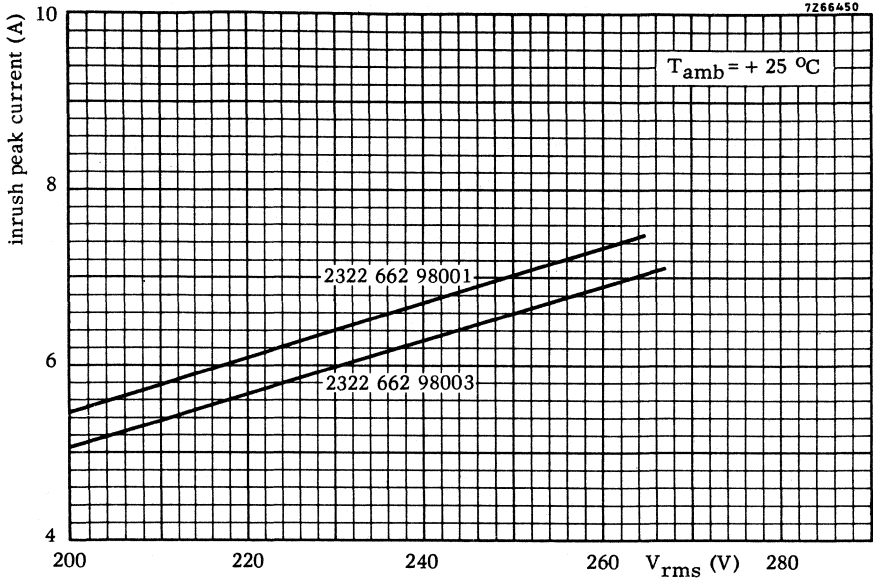

Fig. 7 Typical inrush peak current versus voltage characteristics.

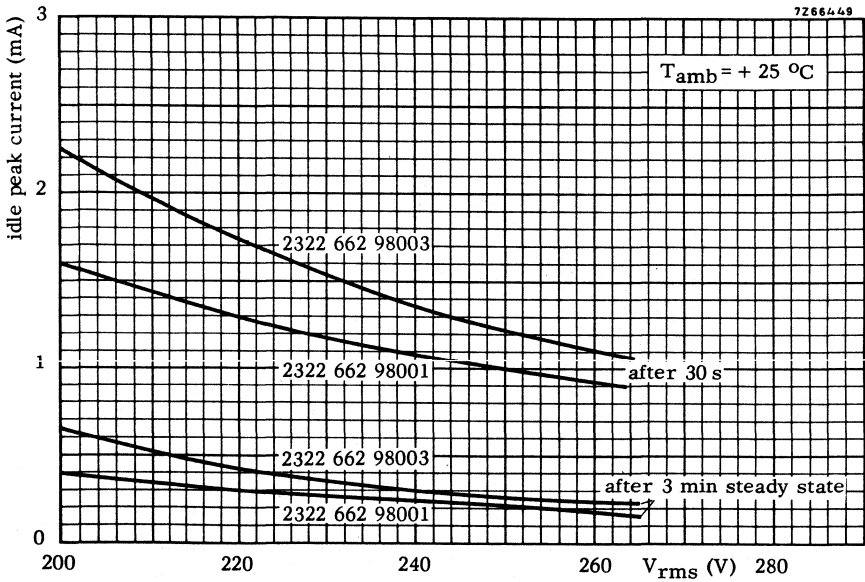

Fig. 8 Typical peak idle current versus voltage characteristics.

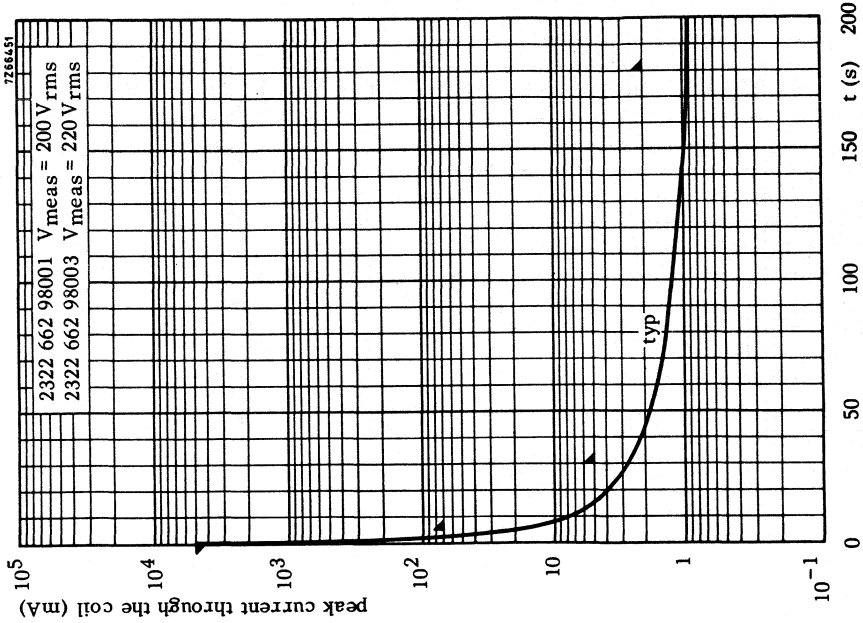

Fig. 10 Typical peak current through the coil versus time characteristic.

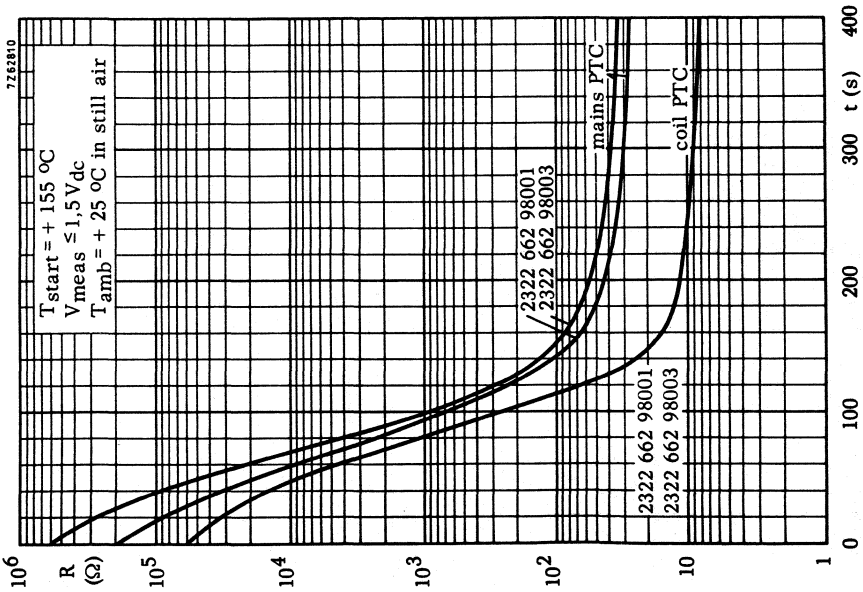

Fig. 9 Typical resistance versus cooling time characteristics of mains PTC thermistor.



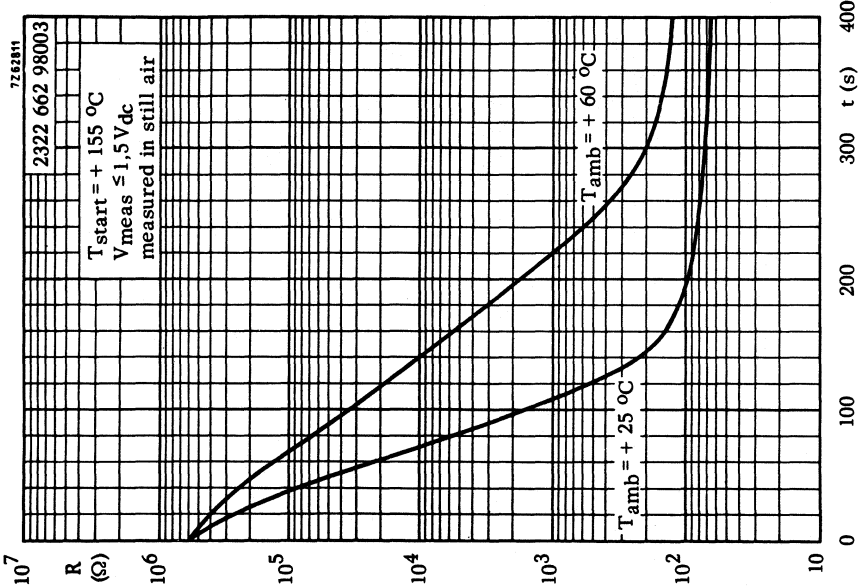

Fig. 12 Typical resistance of circuit versus cooling time characteristics.

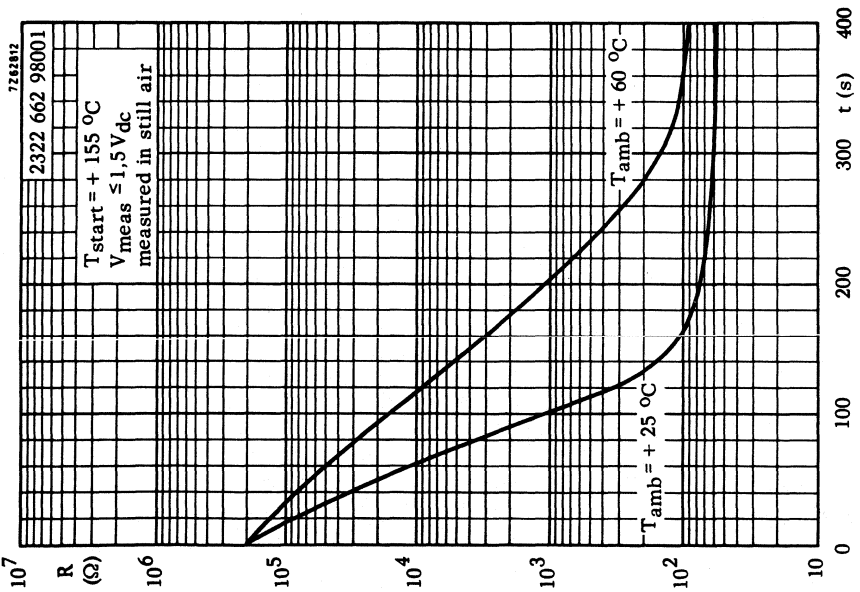

Fig. 11 Typical resistance of circuit versus cooling time characteristics.



## DUAL PTC THERMISTOR

parallel-series

### QUICK REFERENCE DATA

---

Current through the coil at 200 V r.m.s.	
min. inrush peak current	5 A
max. peak current	
after 5 s	70 mA
after 30 s	5 mA
after 3 min	2 mA
Maximum r.m.s. voltage	265 V
Operating temperature range	
at zero power	-25 to +125 °C
at maximum voltage	0 to +60 °C

---

### APPLICATION

In degaussing circuits of colour television sets.

### DESCRIPTION

The dual PTC consists of two disc PTC thermistors clamped between spring contacts. This assembly ensures a good thermal contact between both discs, which is essential for the function of this device. The thermistor is enclosed in a white plastic housing. The three connecting pins are arranged to fit a printed-wiring board with an 0,1 inch grid.

The parallel PTC thermistor is connected across the supply, the series PTC thermistor is connected in series with the degaussing coil. The series PTC would not by itself lower the current to 2 mA, but would stabilize the current above this value. By applying further heat to the series PTC, its resistance will increase to the point where the coil current is limited to 2 mA. This extra heat is provided by the parallel PTC.



**MECHANICAL DATA**

**Outlines**

A and B are to be connected to the mains;  
 A and C are to be connected to the  
 degaussing coil (see also Fig. 2).

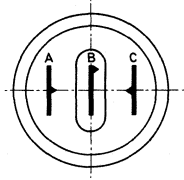
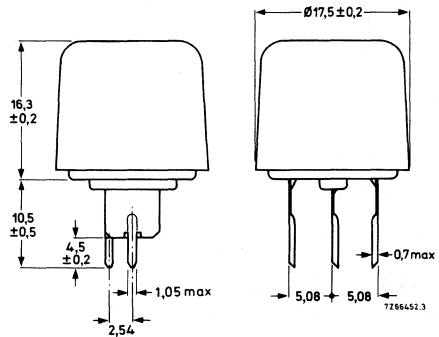

Fig. 1.



- Marking**                    The catalogue number is moulded in the top of the cap.
- Mass**                        7,3 g approximately
- Mounting**                 The thermistor can be soldered directly onto a printed-wiring board.
- Robustness of terminations**
- Tensile strength        20 N
- Soldering**
- Solderability            max. 240 °C, max. 4 s
- Resistance to heat    max. 265 °C, max. 11 s
- Impact**
- Free fall                 1000 mm
- Inflammability**        Uninflammable

**PACKAGING**

500 thermistors in a cardboard box.



**ELECTRICAL DATA**

Unless otherwise specified measured according to IEC draft publication 40 (secretariat) 288.

Current through the coil measured  
in circuit of Fig. 2 at 200 V r.m.s.  
min. inrush peak current  
max. peak current  
after 5 s  
after 30 s  
after 3 min

5 A  
70 mA  
5 mA  
2 mA

Resistance at +25 °C,

$R_s$

~ 40  $\Omega$

$R_p$

~ 3000  $\Omega$

Maximum r.m.s. voltage in circuit \*

265 V

Operating temperature range

at zero power, complete assembly

-25 to +125 °C

at zero power, ceramic in free air (10 h max.)

-55 to +225 °C

at maximum voltage

0 to +60 °C

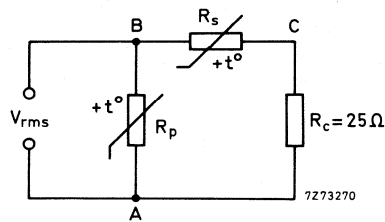

Fig. 2 Measuring circuit.

$R_p$  = parallel PTC;

$R_s$  = series PTC;

$R_c$  = replaces the degaussing  
coil ( $Z = 25 \Omega$ ).

\* In still air, the thermistor soldered on printed-wiring board.

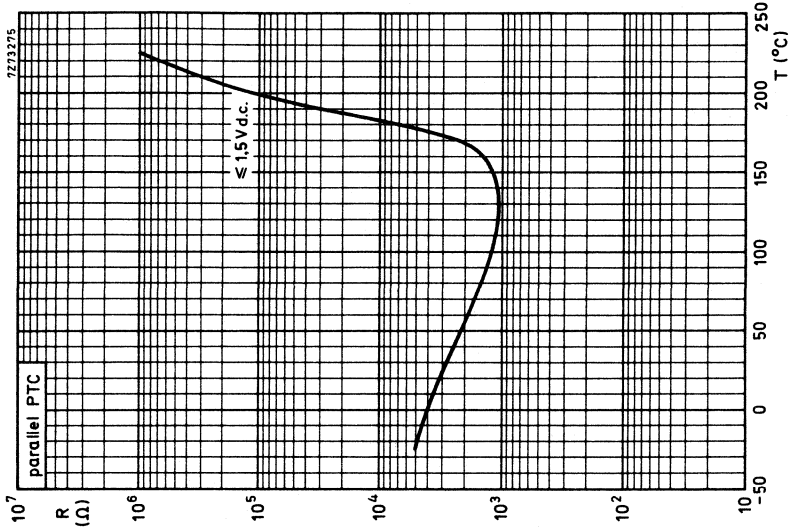

Fig. 4 Typical resistance versus temperature characteristics of the parallel PTC.

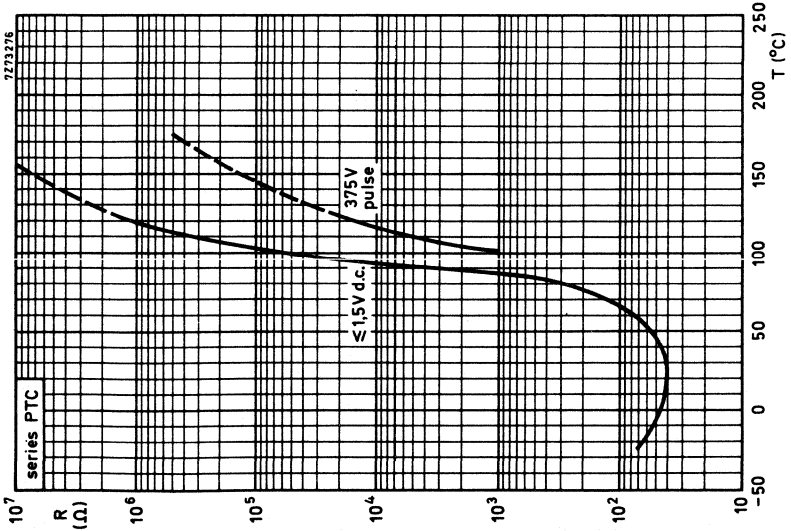

Fig. 3 Typical resistance versus temperature characteristics of the series PTC.



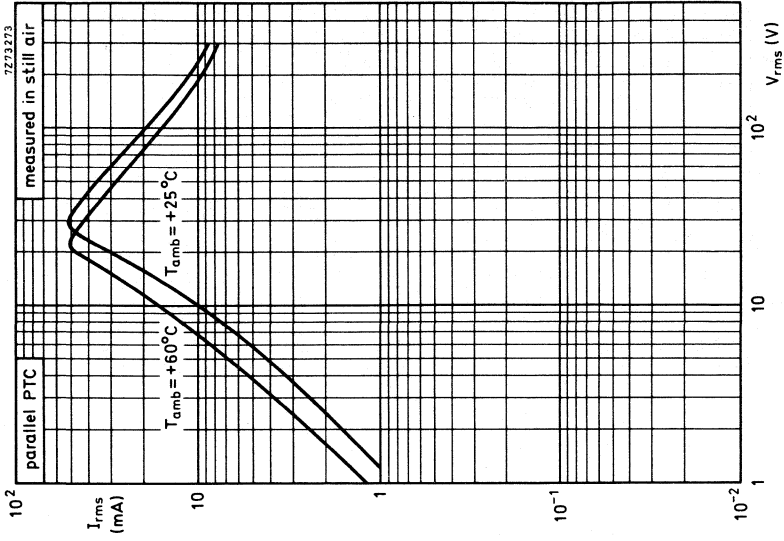

Fig. 6 Typical static current through the parallel PTC versus voltage characteristics.

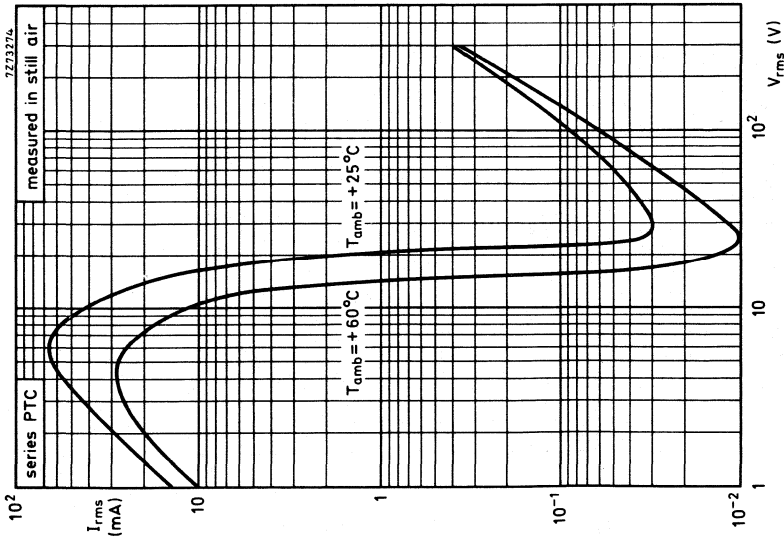

Fig. 5 Typical static current through the coil versus voltage characteristics.



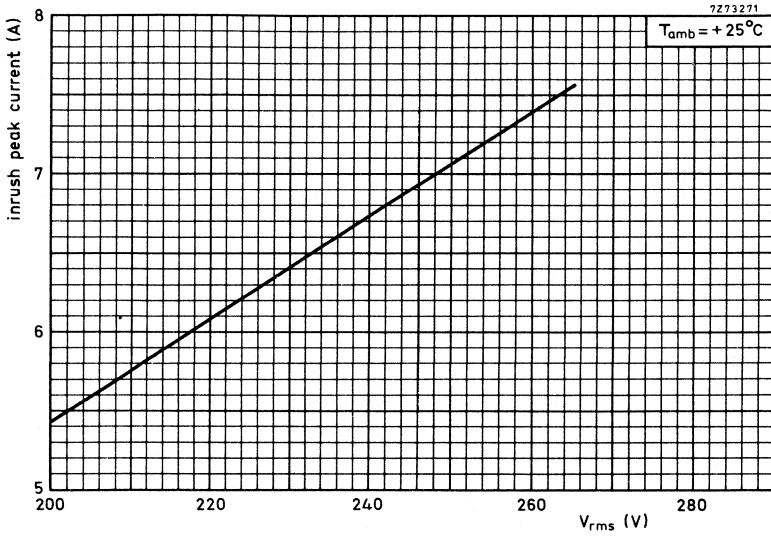

Fig. 7 Typical inrush peak current versus voltage characteristic.

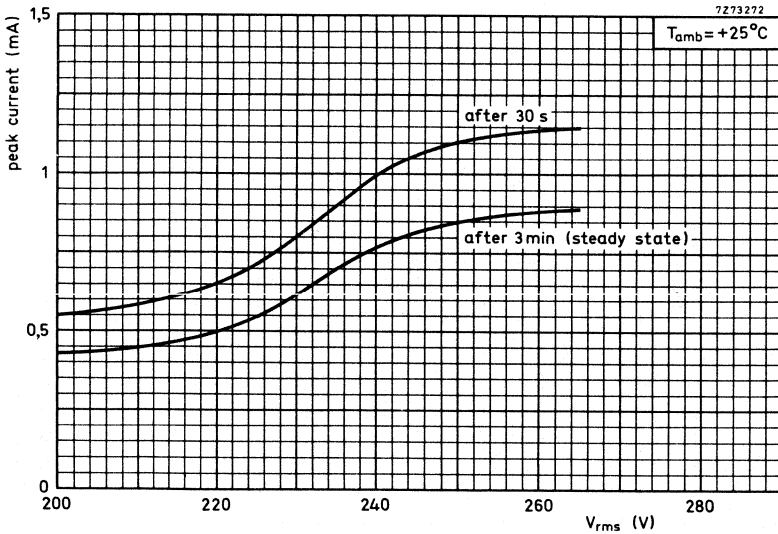

Fig. 8 Typical peak current versus voltage characteristics.

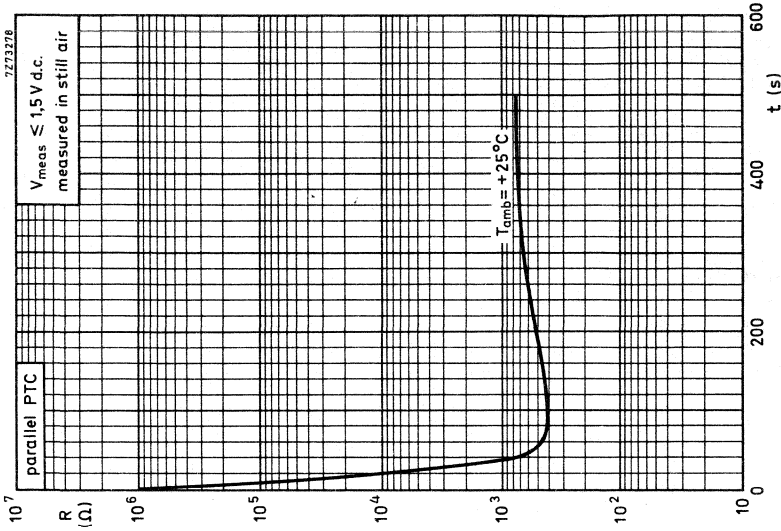

Fig. 10 Typical resistance versus cooling time characteristic of parallel PTC (cooling off after stationary operation at 220 V).

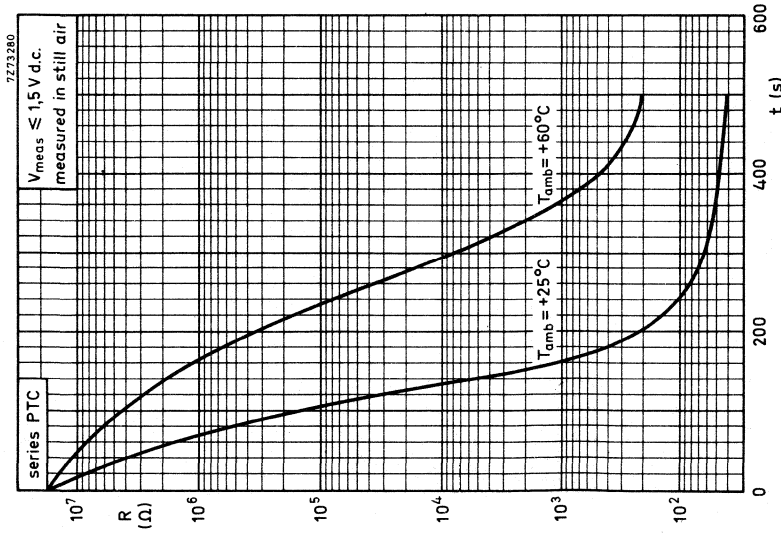

Fig. 9 Typical resistance versus cooling time characteristics of series PTC (cooling off after stationary operation at 220 V).



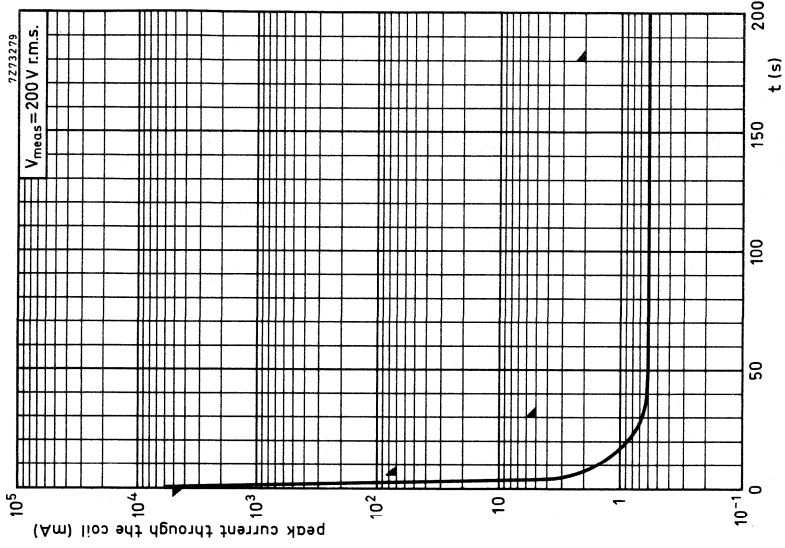

Fig. 12 Typical peak current through the coil versus time characteristic. Peak current limits are indicated by ▲.

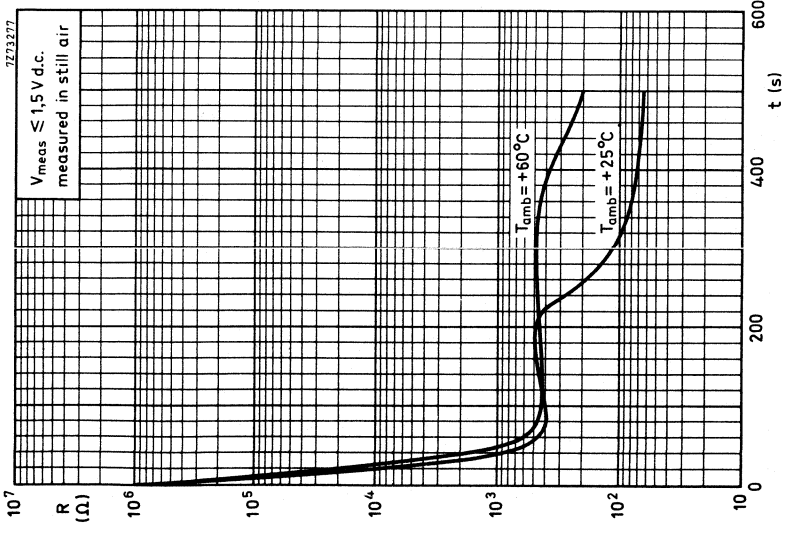

Fig. 11 Typical resistance of circuit versus cooling time characteristics (cooling off after stationary operation at 220 V).



## DUAL PTC THERMISTOR

### QUICK REFERENCE DATA

Current through the coil measured at 100 V r.m.s.	
min. inrush peak current	10 A
max. idle peak current	
after 5 s	140 mA
after 30 s	10 mA
after 3 min	5 mA
Maximum voltage (r.m.s.)	145 V
Switch temperature	
of series PTC	+70 °C
of parallel PTC	+170 °C
Operating temperature range	
at zero power	-25 to +125 °C
at maximum voltage	0 to +60 °C

### APPLICATION

In the degaussing circuit of colour television sets.

### DESCRIPTION

The thermistor consists of two disc PTC thermistors clamped between stainless steel contacts. This assembly ensures a good thermal contact between both discs, which is essential for the function of this device. The thermistor is enclosed in a plastic housing. The three connecting pins are arranged to fit a printed-wiring board with a 0,1 inch grid.



**MECHANICAL DATA**

**Outlines**

A and B are to be connected to the mains;  
 A and C are to be connected to the  
 degaussing coil (see Fig. 2).

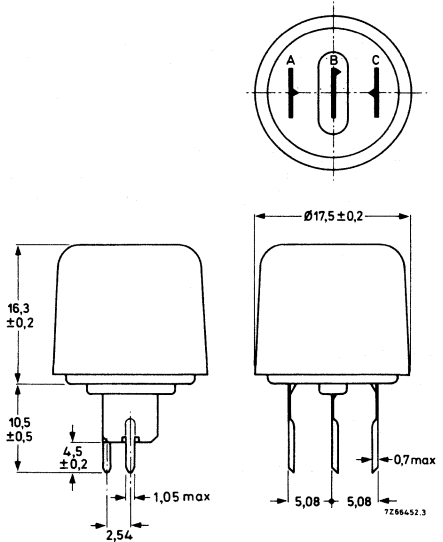

Fig. 1.

**PACKAGING**

500 thermistors in a cardboard box.

- Marking** The catalogue number is moulded in the top of the cap
- Mass** 7,3 g approximately
- Mounting** The thermistor can be soldered directly onto a printed-wiring board
- Robustness of terminations**
- Tensile strength 20 N
- Soldering**
- Solderability max. 240 °C, max. 4 s
- Resistance to heat max. 265 °C, max. 11 s
- Impact**
- Free fall 1000 mm
- Inflammability** Unflammable, in accordance with MIL-STD-202, method 111.

**ELECTRICAL DATA**

All values are approximate unless otherwise specified.

Current through the coil measured in circuit of Fig. 2 at 100 V r.m.s.

min. inrush current	10 A
max. idle peak current	
after 5 s	140 mA
after 30 s	10 mA
after 3 min	5 mA
Resistance at +25 °C	
of series PTC	10 Ω
of parallel PTC	400 to 2400 Ω
at $T_{amb} = +200\text{ °C}$ and 198 V pulsed	
of parallel PTC	> 10 kΩ
Switch temperature	
of series PTC	+70 °C
of parallel PTC	+170 °C
Temperature coefficient	
of series PTC	+16%/K
of parallel PTC	+20%/K
Maximum voltage (r.m.s.) in circuit of Fig. 2	145 V
Operating temperature range	
at zero power	-25 to +125 °C
at maximum voltage	0 to +60 °C

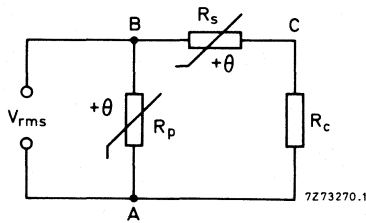

Fig. 2 Measuring circuit.

- $R_p$  = parallel PTC;
- $R_s$  = series PTC;
- $R_c$  = 6,2 Ω (replaces degaussing coil).



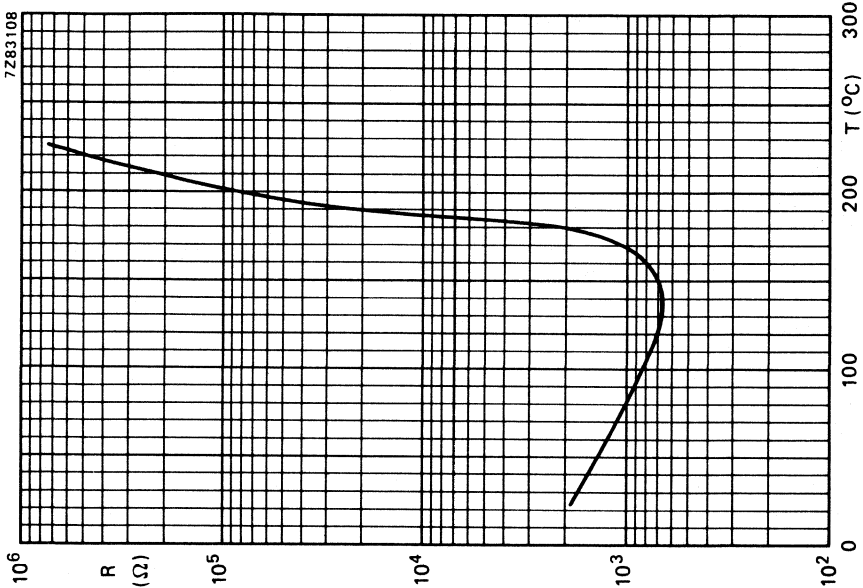

Fig. 4 Parallel PTC.

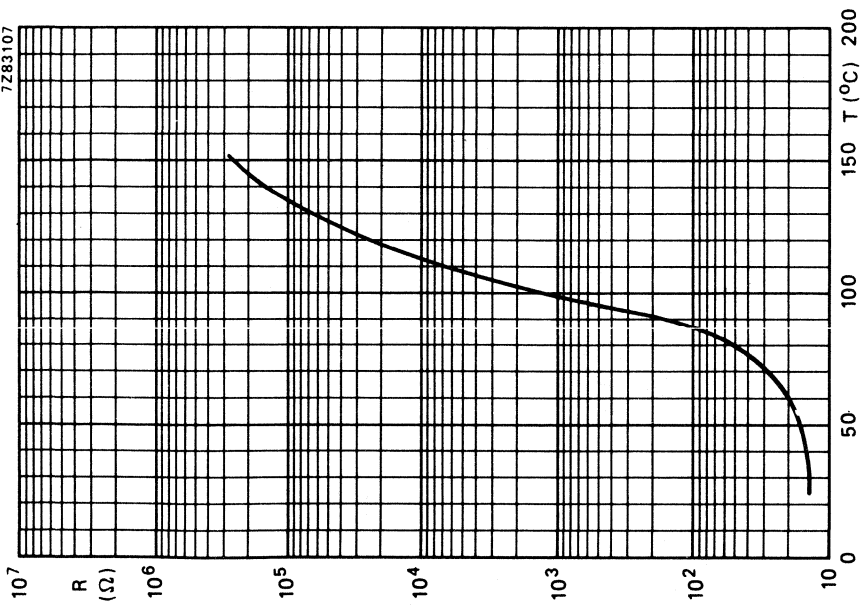

Fig. 3 Series PTC.

Typical resistance/temperature characteristics.

## PTC THERMISTOR

disc

### QUICK REFERENCE DATA

Resistance value at +25 °C	max. 1,1 $\Omega$
Resistance value at +85 °C	max. 0,9 $\Omega$
Switch temperature	+140 °C
Temperature coefficient	+8%/K
Maximum r.m.s. voltage	18 V
Operating temperature range	-25 to +175 °C
at zero power	0 to +85 °C
at maximum voltage	

### APPLICATION

Overload protection, e.g. of loudspeakers.

### DESCRIPTION

This positive temperature coefficient thermistor consists of a disc with two tinned brass wires.

### MECHANICAL DATA

#### Outlines

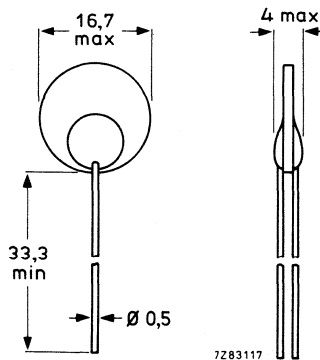

Fig. 1.

### PACKAGING

2000 thermistors in a cardboard box.

<b>Marking</b>	none
<b>Mass</b>	1,25 g approximately
<b>Mounting</b>	in any position by soldering
<b>Robustness of terminations</b>	
Tensile strength	10 N
Bending	5 N
<b>Soldering</b>	
Solderability	max. 240 °C, max. 4 s
Resistance to heat	max. 265 °C, max. 11 s
<b>Impact</b>	200 mm free fall
<b>Inflammability</b>	uninflammable
<b>ELECTRICAL DATA</b>	
Resistance at +25 °C	max. 1,1 Ω
Resistance at +85 °C	max. 0,9 Ω
Switch temperature	+140 °C approx.
Switching current at $T_{amb} = +25\text{ °C}$	max. 1,17 A
Max. current at which no switching occurs at $T_{amb} = +25\text{ °C}$	0,95 A
Temperature coefficient	+8%/K approx.
Maximum voltage (r.m.s.)	18 V
Steady state current at $T_{amb} = +25\text{ °C}$ , $V_{rms} = 18\text{ V}$	max. 140 mA
Response time at $T_{amb} = +25\text{ °C}$ , $I = 2\text{ A}$	max. 15 s
Operating temperature range at zero power	-25 to +175 °C
at maximum voltage	0 to +85 °C

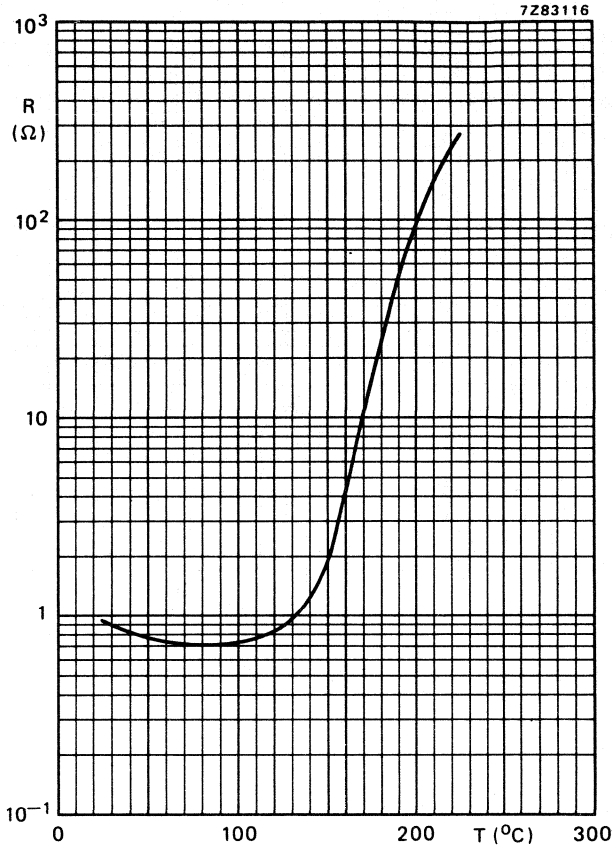

Fig. 2 Typical resistance/temperature characteristic.



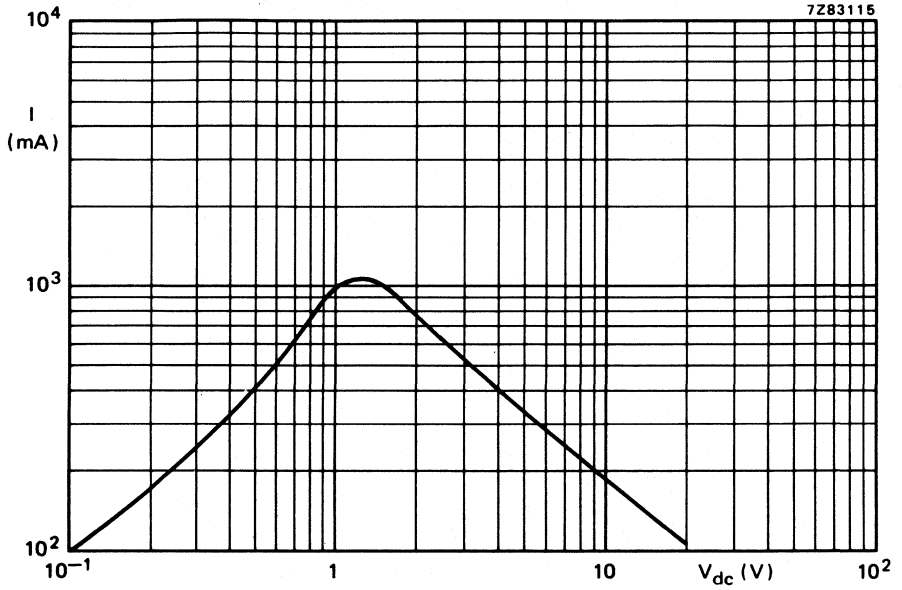

Fig. 3 Typical voltage/current characteristic.





## PTC CERAMIC HEATING ELEMENTS

### QUICK REFERENCE DATA

Maximum resistance at + 25 °C	600 to 5000 $\Omega$
Switch temperature	120-160-200 °C
Maximum voltage, r.m.s.	265 V
Inrush current at 265 V	0,6 to 7,5 A
Operating temperature range at zero power	-40 to + 125 °C
max. power	-25 to + 85 °C

### APPLICATION

Heating element for general use.

### DESCRIPTION

These thermistors have a positive temperature coefficient. They consist of a disc, with centre hole, with two aluminium contacts.

### MECHANICAL DATA

#### Outlines

Table 1

catalogue number	D	a	b	c	d
2322 663 . . . . .	$\pm 0,8$	max.	min.	$\pm 0,15$	$\pm 0,3$
94001	16	1,2	4,3	1,6	4,9
94002	16	1,2	4,3	1,6	4,9
94003	16	1,2	4,3	1,6	4,9
94005	13	1,2	2,8	1,6	4,9
94006	13	1,2	2,8	1,6	4,9
94007	13	1,2	2,8	1,6	4,9

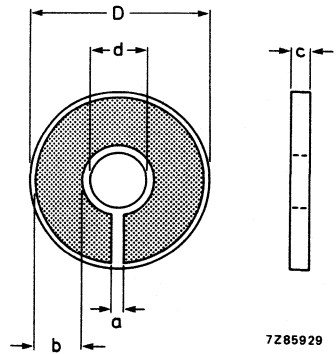

Fig. 1.

<b>Marking</b>	None
<b>Mass</b>	Types 2322 663 94001, 2, 3: 1,6 g approximately Types 2322 663 94005, 6, 7: 1,0 g approximately
<b>Mounting</b>	In any position by clamping
<b>Impact</b>	Free fall, 200 mm
<b>Inflammability</b>	Uninflammable

### PACKAGING

840 thermistors on preformed polystyrene sheets.

## ELECTRICAL DATA

Unless otherwise specified measured according to IEC 738-1 (1982)

Table 2

	catalogue number 2322 663 followed by						
	94001	94002	94003	94005	94006	94007	
Max. resistance at 25 °C	600	1600	3000	900	3000	5000	Ω
Resistance at 145 °C and 375 V (pulse)	400 to 8000	450 to 6500	500 to 5000	600 to 10000	650 to 8500	700 to 7000	Ω
Switch temperature	120	160	200	120	160	200	°C
Tolerance on switch temperature	± 5	± 6,5	± 8	± 5	± 6,5	± 8	°C
Inrush current at 265 V (r.m.s.)	2,4 to 7,5	1,3 to 3,8	1,0 to 3,8	1,3 to 4,1	0,7 to 2,0	0,6 to 2,1	A (peak)
Max. steady state current at 265 V (r.m.s.) and 25 °C	13,5	14,5	19	9	11	14	mA
Max. voltage (r.m.s.)	265						V
Operating temp. range at zero power	-40 to + 125						°C
max. power	-25 to + 85						°C



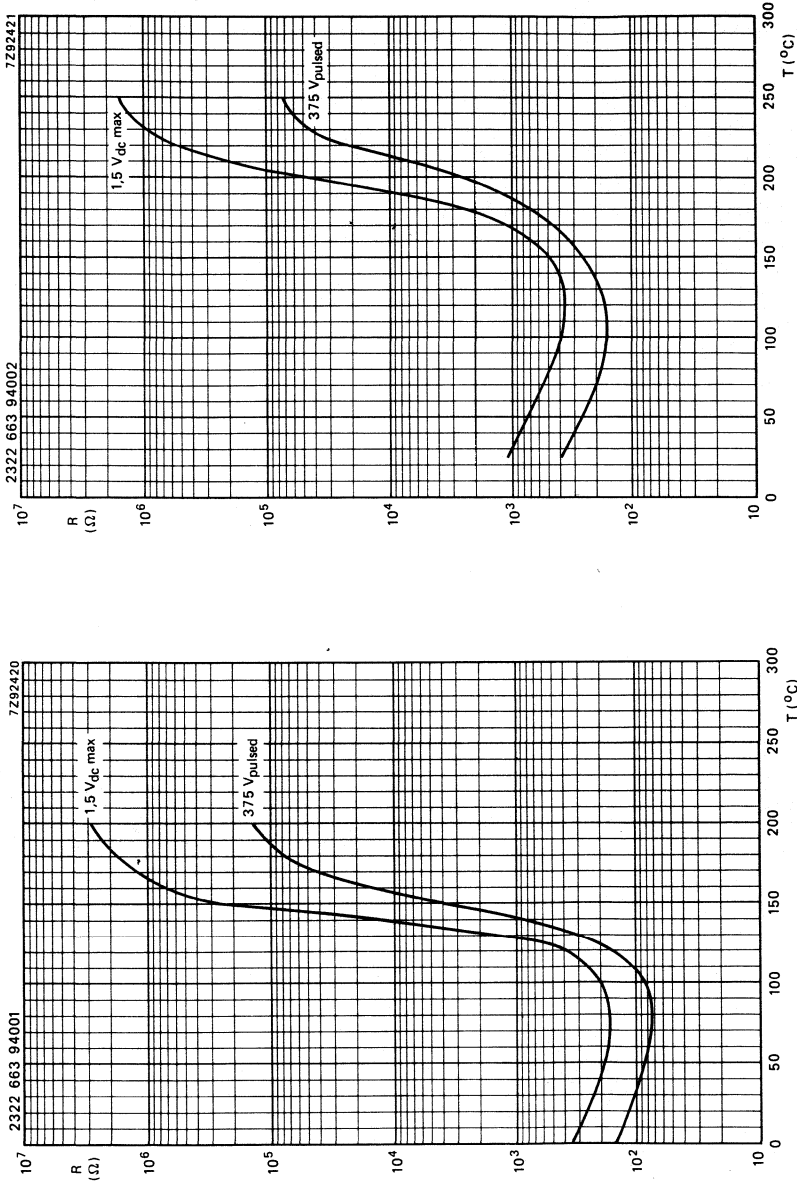

Fig. 2.

Fig. 3.

Typical resistance/temperature characteristics.



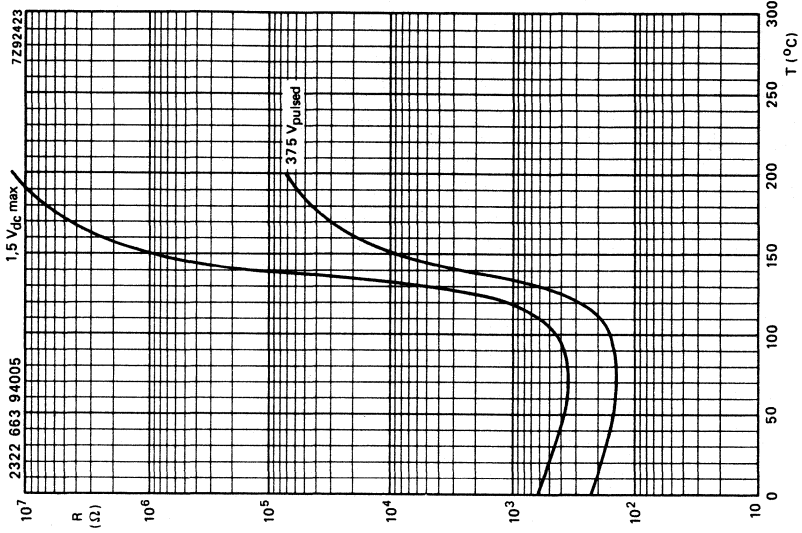

Fig. 5.

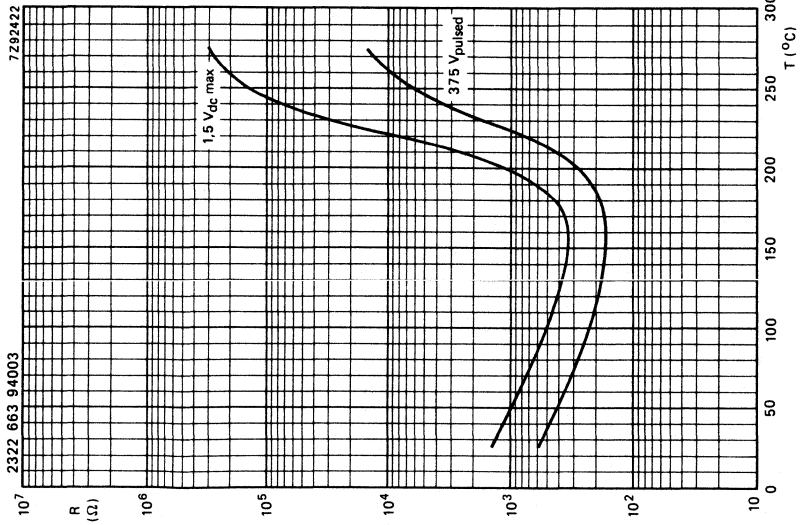

Fig. 4.

Typical resistance/temperature characteristics.

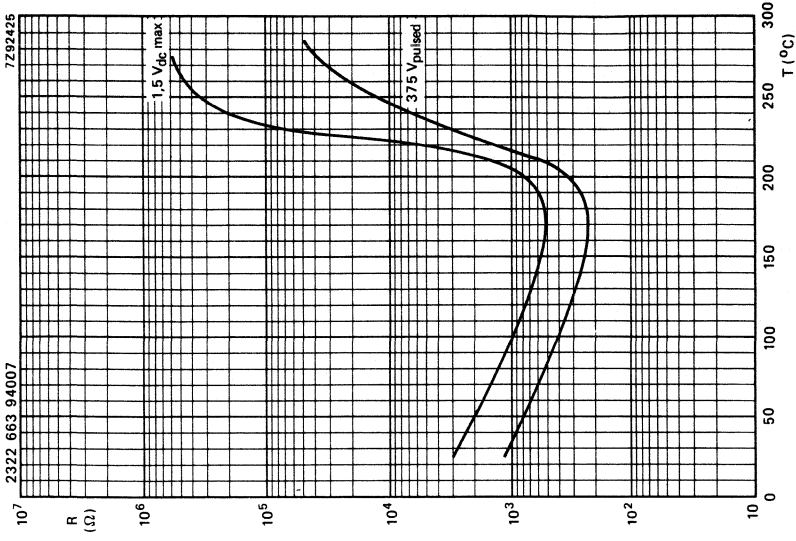

Fig. 7.

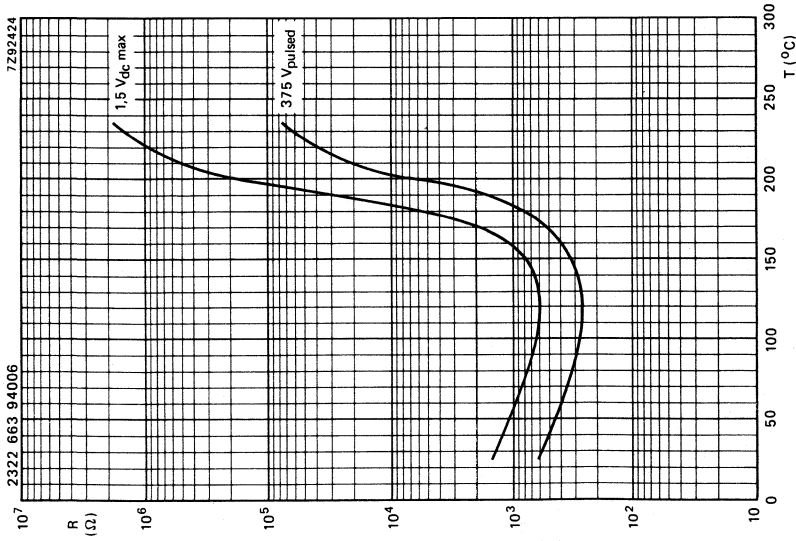

Fig. 6.

Typical resistance/temperature characteristics.





## PTC CERAMIC HEATING ELEMENTS

### QUICK REFERENCE DATA

Maximum resistance at + 25 °C	2,5 and 3,5 $\Omega$
Switch temperature	120 -160 -200 °C
Maximum voltage, d.c.	16 V
Inrush current at 16 V	11, 13 and 16 A
Operating temperature range at zero power	-40 to + 125 °C
max. power	-25 to + 85 °C

### APPLICATION

Heating element for general use.

### DESCRIPTION

These thermistors have a positive temperature coefficient. They consist of a disc, with centre hole, with two aluminium contacts.

### MECHANICAL DATA

#### Outlines

Table 1

catalogue number 2322 663 . . . . .	D $\pm 0,8$	a max.	b min.	c $\pm 0,15$	d $\pm 0,3$
95002	16	1,2	4,3	1,0	4,9
95003	16	1,2	4,3	1,0	4,9
95004	16	1,2	4,3	1,0	4,9
95005	13	1,2	2,8	1,0	4,9
95006	13	1,2	2,8	1,0	4,9
95007	13	1,2	2,8	1,0	4,9

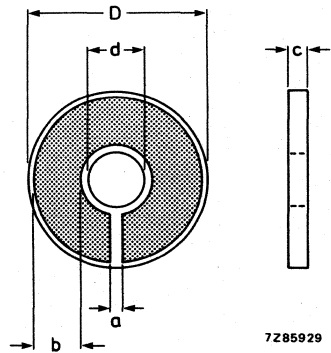

Fig. 1.

**Marking** None

**Mass** Types 2322 663 95002, 3, 4: 1,2 g approximately  
Types 2322 663 95005, 6, 7: 0,8 g approximately

**Mounting** In any position by clamping

**Impact** Free fall, 200 mm

**Inflammability** Uninflammable

### PACKAGING

1260 thermistors on preformed polystyrene sheets.

## ELECTRICAL DATA

Unless otherwise specified measured according to IEC 738-1 (1982).

Table 2

	catalogue number 2322 663 followed by						
	95002	95003	95004	95005	95006	95007	
Max. resistance at 25 °C	2,5	2,5	2,5	3,5	3,5	3,5	Ω
Temperature range for resistance value of 9 Ω	128 to 140	166 to 183	205 to 225	123 to 135	160 to 176	205 to 225	°C
Switch temperature	120	160	200	120	160	200	°C
Tolerance on switch temp.	± 5	± 6,5	± 8	± 5	± 6,5	± 8	°C
Max. inrush current at 16 V (d.c.)	13	13	16	11	11	13	A
Max. steady state current at 16 V (d.c.) and 25 °C	150	185	240	115	150	205	mA
Max. voltage (d.c.)	16						V
Operating temp. range at zero power	-40 to + 125						°C
max. power	-25 to + 85						°C



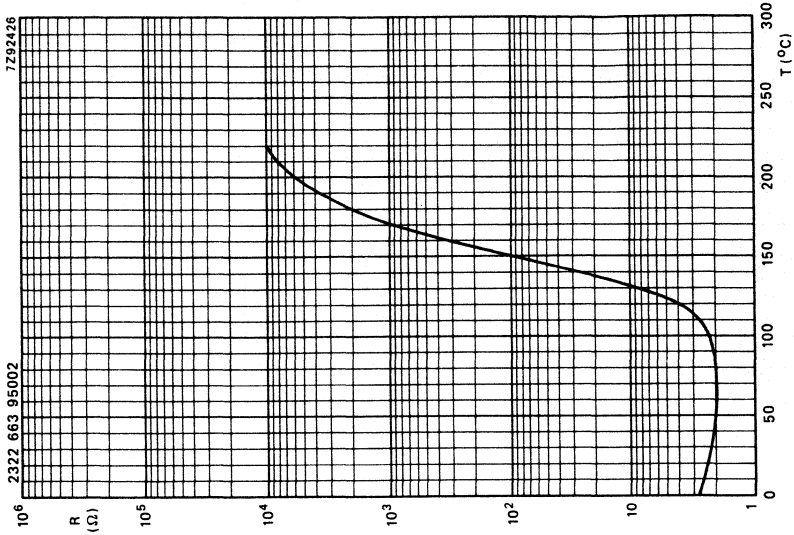

Fig. 3.

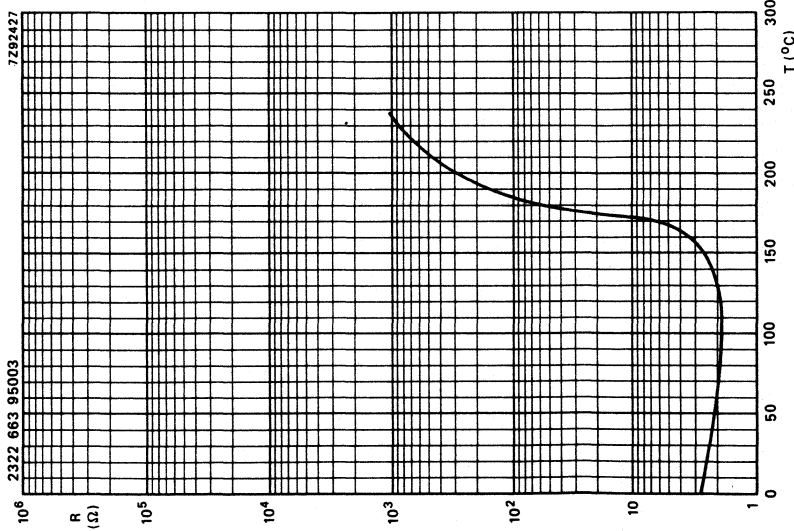

Fig. 2.

Typical resistance/temperature characteristics.



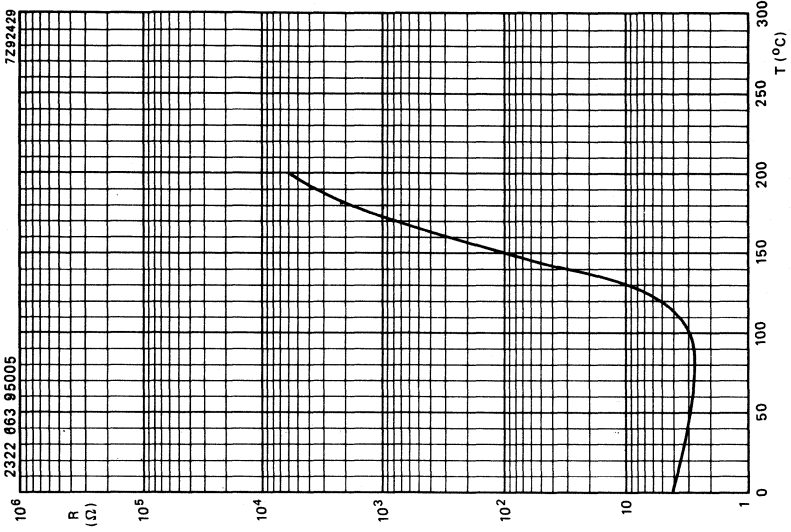

Fig. 5.

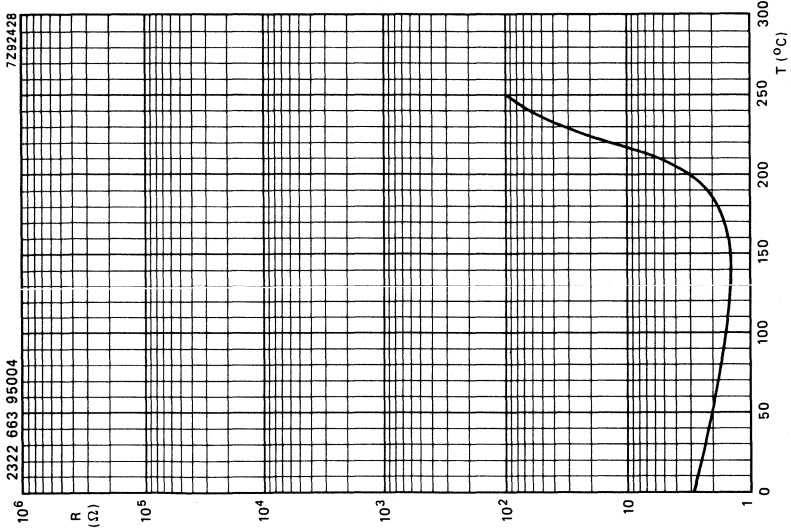

Fig. 4.

Typical resistance/temperature characteristics.

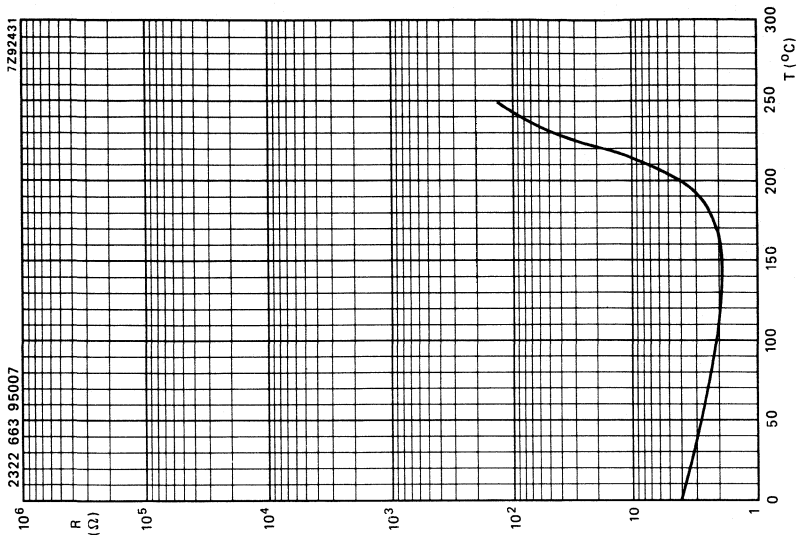

Fig. 7.

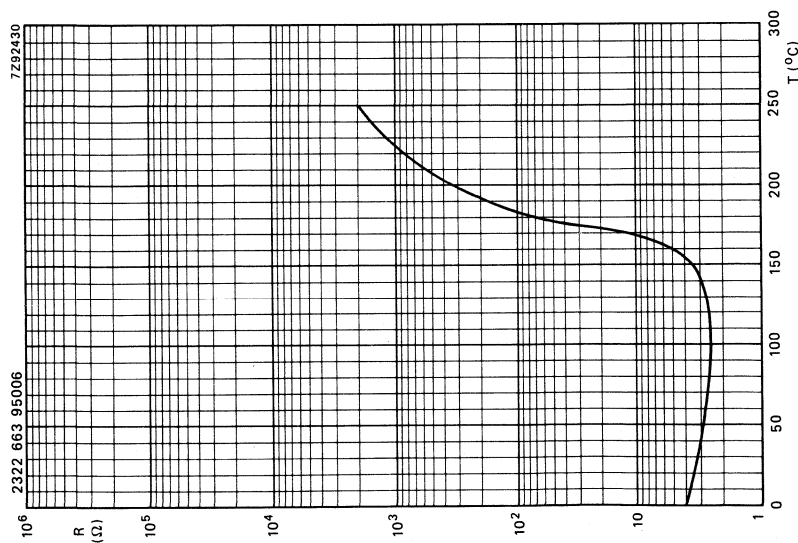

Fig. 6.

Typical resistance/temperature characteristics.





## PTC THERMISTOR

disc

### QUICK REFERENCE DATA

Resistance value at +25 °C	max. 0,6 $\Omega$
Resistance value at +150 °C $V_{\text{pulse}} = 16 \text{ V}$	min. 40 $\Omega$
Switch temperature	+85 °C
Temperature coefficient	+10%/K
Maximum d.c. voltage	16 V
Dissipation factor	27 mW/K
Operating temperature range at zero power	-25 to +155 °C
at $V_{\text{max}}$	-25 to +55 °C

### APPLICATION

Overload protection, e.g. of relay coils, loudspeakers, etc.

### DESCRIPTION

The thermistor has a positive temperature coefficient. It consists of a disc with two tinned copper wires. The thermistor body is blue lacquered, but not insulated.

### MECHANICAL DATA

#### Outlines

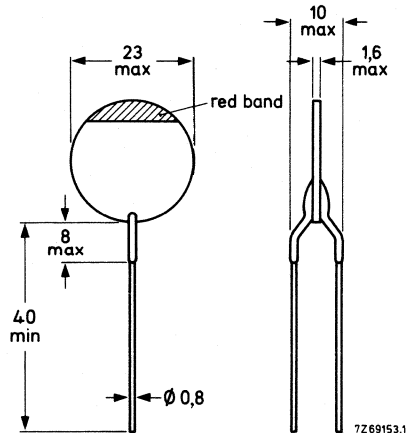

Fig. 1.

### PACKAGING

100 thermistors in a cardboard box.

<b>Marking</b>	The thermistors are marked with a red band.
<b>Mass</b>	~ 2,3 g
<b>Mounting</b>	In any position by soldering
<b>Robustness of terminations</b>	
Tensile strength	20 N
Bending	10 N
<b>Soldering</b>	
Solderability	max. 240 °C, max. 4 s
Resistance to heat	max. 240 °C, max. 4 s
<b>ELECTRICAL DATA</b>	
Resistance at -25 °C	max. 1,15 Ω *
Resistance between +25 and +55 °C	max. 0,6 Ω *
Resistance at +150 °C	
V <sub>pulse</sub> = 16 V	min. 40 Ω **
Switch temperature	~ +83 °C
Temperature coefficient	~ 10%/K
Dissipation factor	~ 27 mW/K
Heat capacity	~ 1,2 J/K
Thermal time constant	~ 45 s
Operating temperature range	
at zero power	-25 to +155 °C
at maximum voltage	-25 to +55 °C
Maximum voltage (d.c.)	16 V

\*\*\*

\* D.C. measuring voltage not exceeding 1,5 V to avoid internal heating.

\*\* Measurement made without internal heating.

\*\*\* Measurements made with specimen in phosphor bronze clips, in still air.

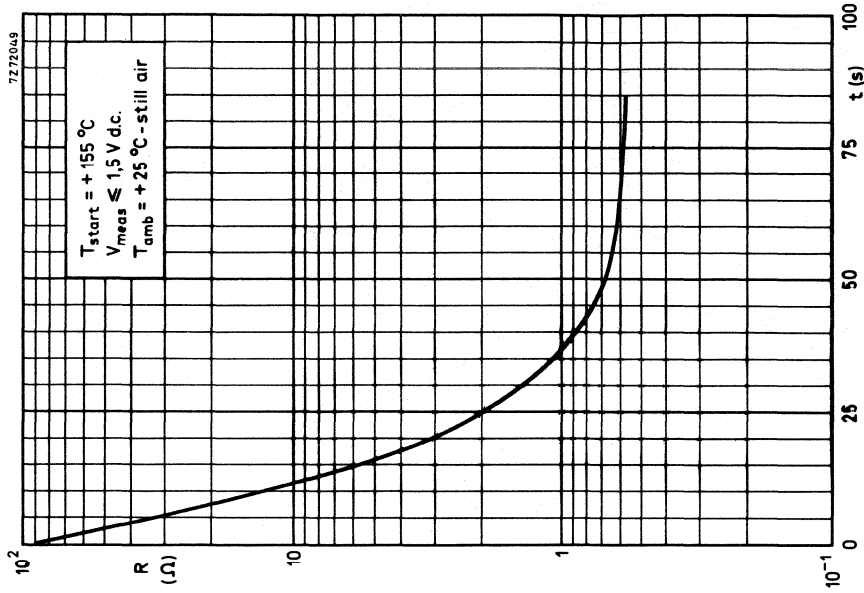

Fig. 3 Typical resistance/time (cooling) characteristic.

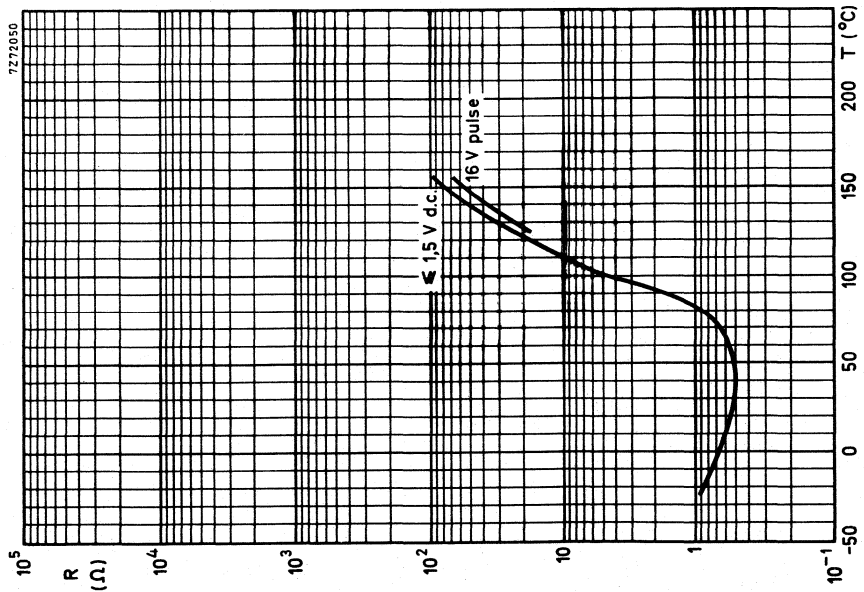

Fig. 2 Typical resistance/temperature characteristics.



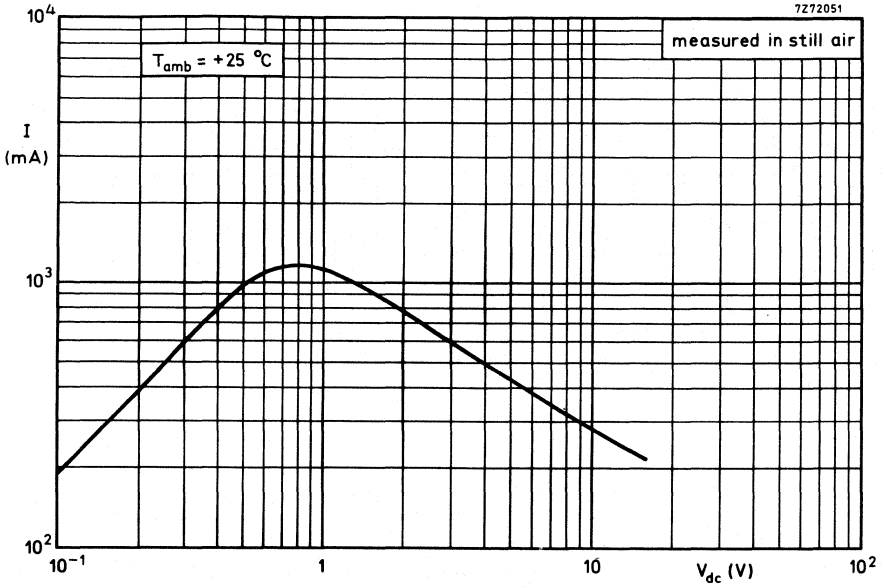

Fig. 4 Typical voltage/current characteristic.





## PTC THERMISTOR

## QUICK REFERENCE DATA

Resistance	
at +25 °C	$120 \pm 30 \Omega$
at +155 °C	$> 2 \text{ k}\Omega$
Switch temperature	$\approx 145 \text{ }^\circ\text{C}$
Temperature coefficient	$> 8\%/K$
Maximum voltage (d.c.) at +40 °C	34 V
Response time	$\leq 2 \text{ S}$
Operating temperature range	
at zero power	$-25 \text{ to } +155 \text{ }^\circ\text{C}$
at maximum voltage	$0 \text{ to } +40 \text{ }^\circ\text{C}$

## APPLICATION

Current stabilizer for compensation of variation in telephone line resistance.

## DESCRIPTION

A miniature thermistor element mounted in a glass envelope model DO-7 with two axial leads.

## MECHANICAL DATA

## Outlines

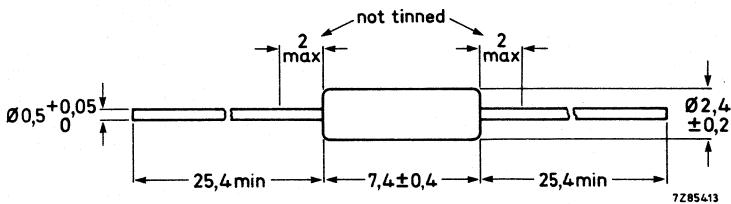
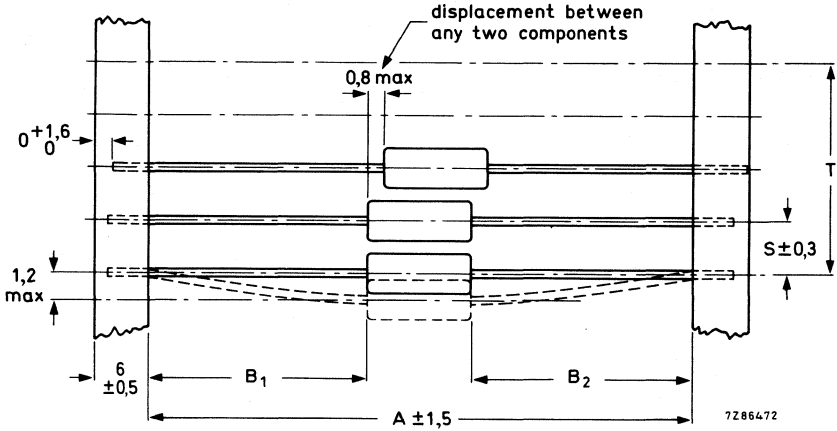

Fig. 1.

**STANDARD PACKAGING**

The thermistors are supplied in quantities of 5000 on bandolier which is zig-zag folded in an ammpack. Configuration of bandolier



style	A	$B_1 - B_2$ $\pm \text{max.}$	S (spacing)	T (max. deviation of spacing)
TPJ	53	1,2	5	2 mm for 10 spacings, 1,5 mm for 5 spacings

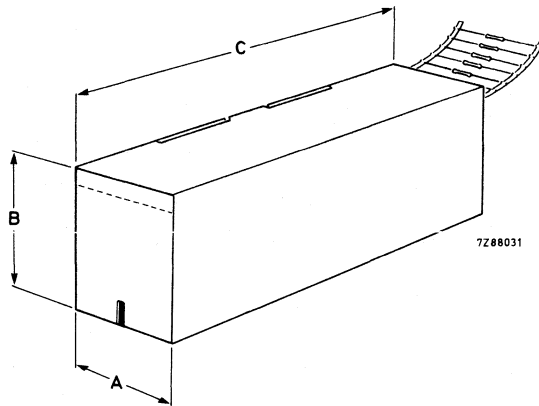

Fig. 3 Dimensions of ammpack in mm.

- A = 75 mm
- B = 95 mm
- C = 270 mm

## PTC THERMISTORS

disc

### QUICK REFERENCE DATA

Resistance value between $-20$ and $(T_s - 10)$ °C	30 to 250 $\Omega$
Resistance value at $(T_s + 25)$ °C and $V_{\text{pulse}} = 7,5$ V	$\geq 4000$ $\Omega$
Switch temperature, $T_s$	70 to 150 °C
Temperature coefficient	18 to 38%/K
Maximum voltage (d.c.)	25 V
Dissipation factor (version with leads)	5,7 mW/K
Operating temperature range	
at zero power	$-25$ to $(T_s + 40)$ °C
at maximum voltage	0 to $(T_s + 25)$ °C

### APPLICATION

Temperature sensors in domestic appliances, fire alarms, car electronics, etc.

### DESCRIPTION

These thermistors have a positive temperature coefficient. They consist of a disc with or without two tinned copper wires. The thermistor without leads is not lacquered nor insulated. The thermistor with leads is lacquered but not insulated.

### MECHANICAL DATA

Outlines

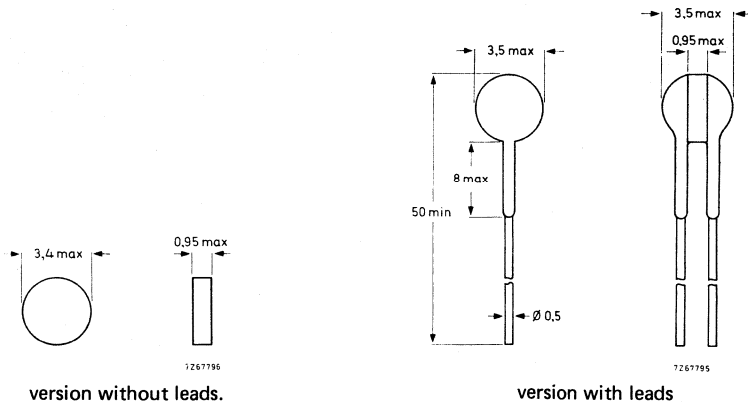

Fig. 1.

2322 672 91002  
to  
2322 672 91035

**Marking**

Version without leads

none

Version with leads

colour code, see table

**Mass**

Version without leads

0,04 g approx.

Version with leads

0,29 g approx.

**Mounting** (for version with leads only)

In any position by soldering.

**Robustness of terminations** (for version with leads only)

Tensile strength

10 N

Bending

5 N

**Soldering** (for version with leads only)

Solderability

max. 240 °C, max. 4 s

Resistance to heat

max. 265 °C, max. 11 s

**Impact**

Free fall

**PACKAGING**

Version without leads: 5000 thermistors in a cardboard box.

Version with leads: 500 thermistors in a cardboard box.



**ELECTRICAL DATA**

All values in the electrical data without further indication are approximate values.

$T_s$ °C	temperature coefficient	balance voltage	voltage dependence $\beta$ at $(T_s + 25)$ °C	colour code for version	catalogue number 2322 672 .....	
	%/K	V d.c.		with leads	with leads	without leads
70	18	19	0,32	violet	91002	91026
80	21	27	0,40	grey	91003	91027
90	31	16	0,36	white	91004	91028
100	33	17	0,35	black	91005	91029
110	38	11	0,36	brown	91006	91031
120	27	34	0,38	red	91007	91032
130	33	13	0,34	orange	91008	91033
140	33	20	0,35	yellow	91009	91034
150	23	20	0,31	green	91011	91035

Resistance value between  $-20$  and  $(T_s - 10)$  °C30 to 250  $\Omega$  \*Resistance value at  $(T_s + 5)$  °C $\leq 550 \Omega$  \*Resistance value at  $(T_s + 15)$  °C $\geq 1330 \Omega$  \*Resistance value at  $(T_s + 25)$  °C,  $V_{\text{pulse}} = 7,5$  V $\geq 4000 \Omega$  \*\*

Maximum voltage (d.c.)

25 V

Dissipation factor (version with leads)

5,7 mW/K

Thermal time constant (version with leads)

9 s

Heat capacity (version with leads)

0,05 J/K

Operating temperature range

at zero power

 $-25$  to  $(T_s + 40)$  °C

at maximum voltage

0 to  $(T_s + 25)$  °C

\* Measuring voltage not exceeding 2,5 V d.c. to avoid internal heating.

\*\* Measurements made without internal heating occurring.

2322 672 91002  
to  
2322 672 91035

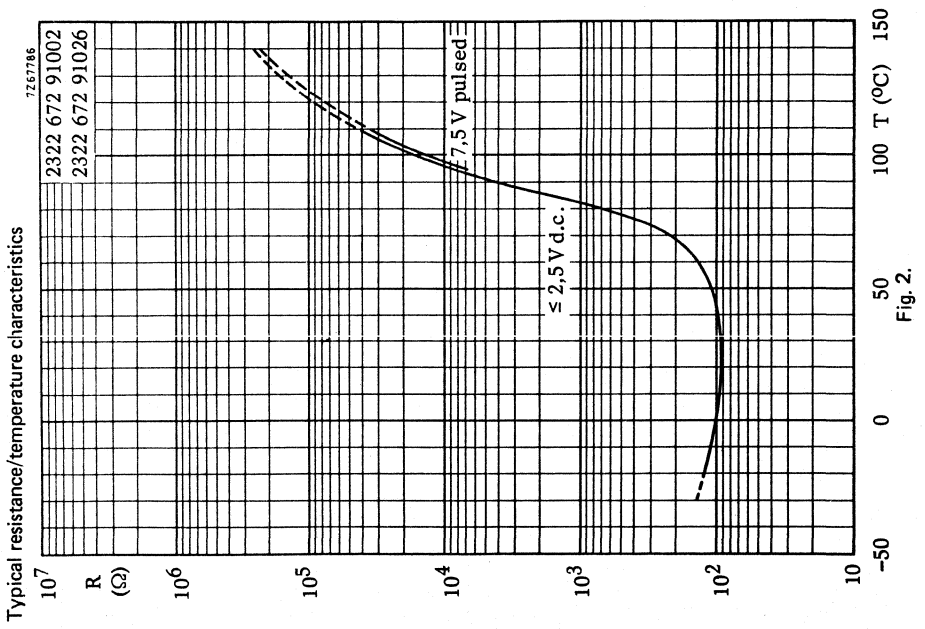

Fig. 2.

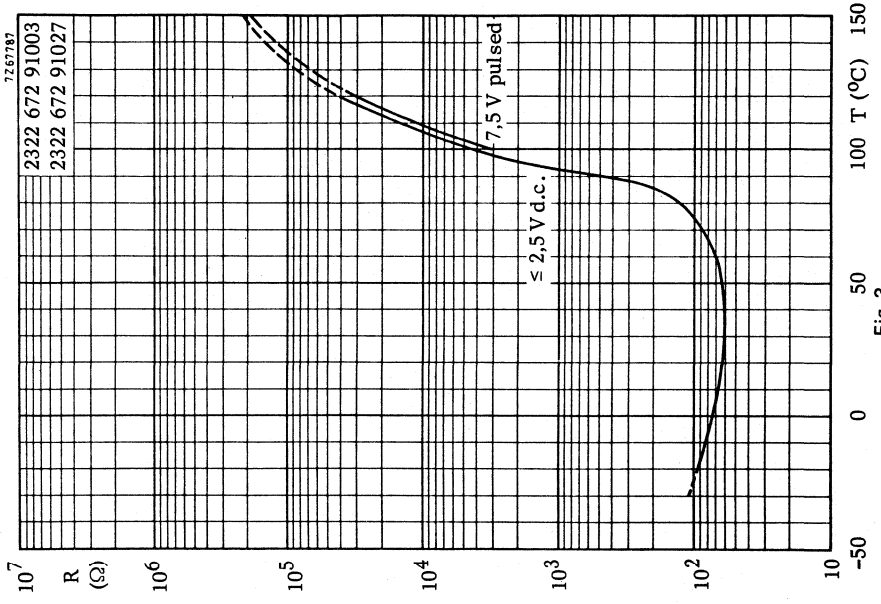

Fig. 3.

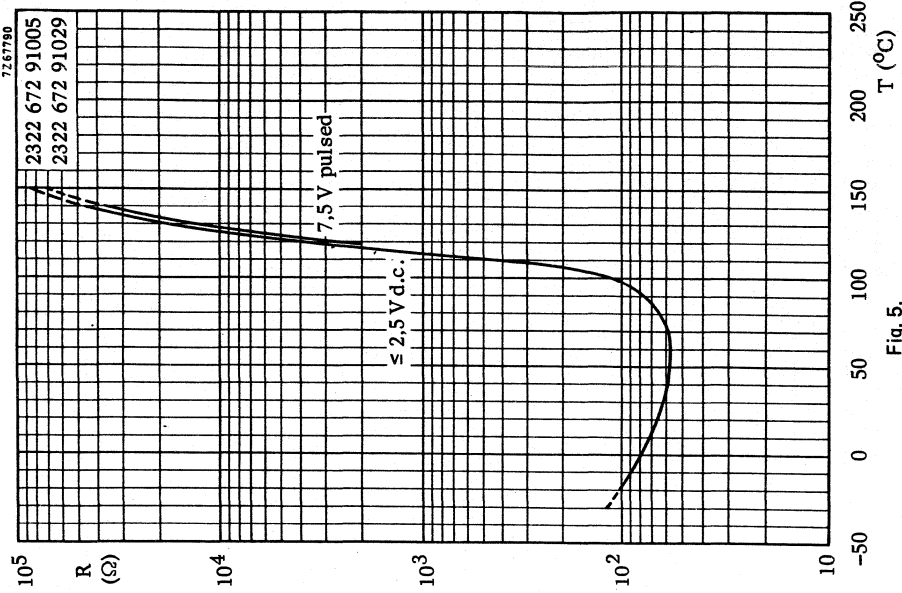

Fig. 5.

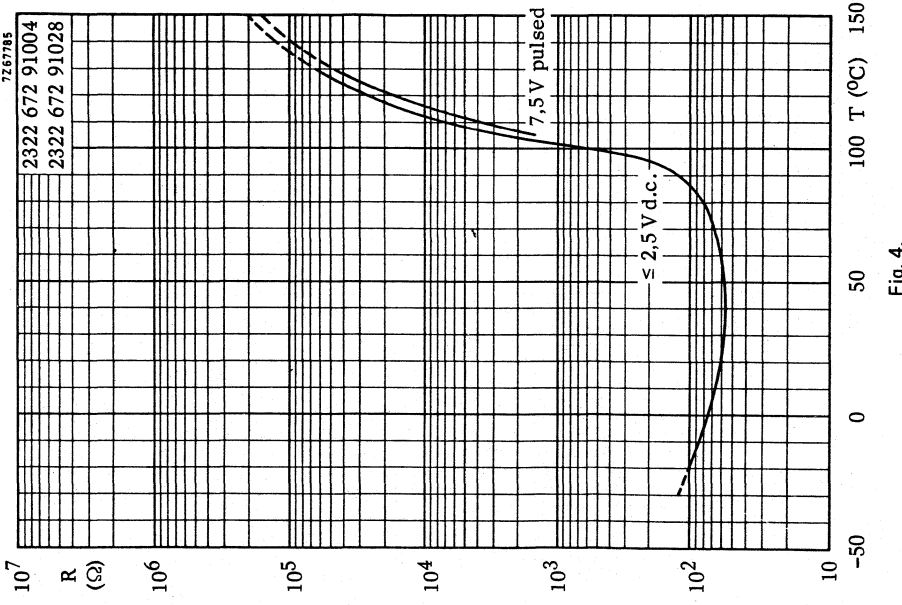

Fig. 4.



2322 672 91002  
to  
2322 672 91035

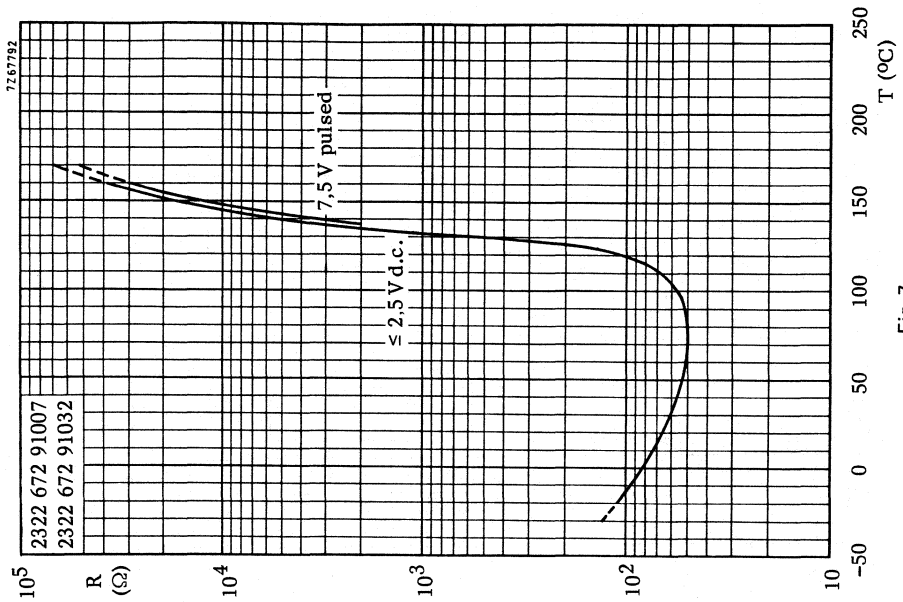

Fig. 7.

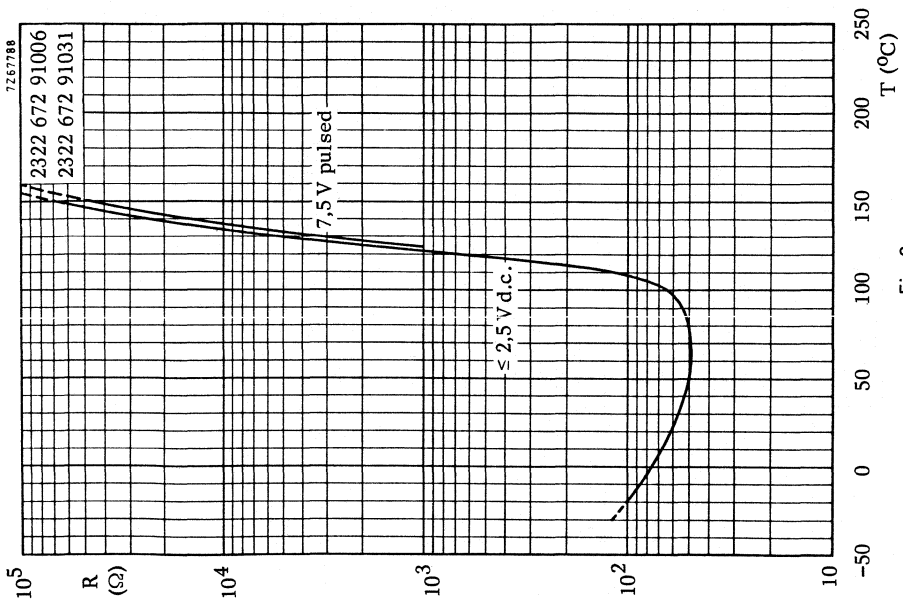

Fig. 6.



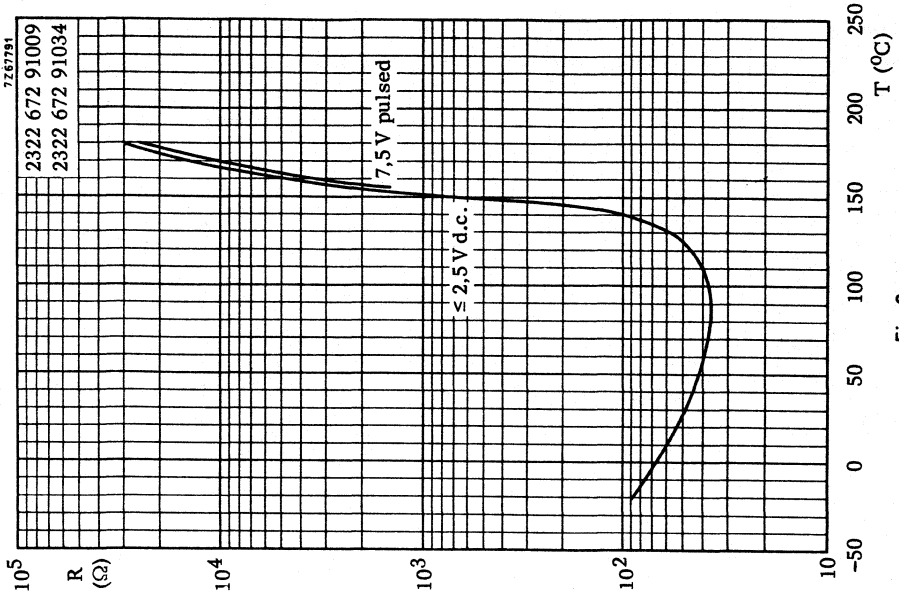

Fig. 9.

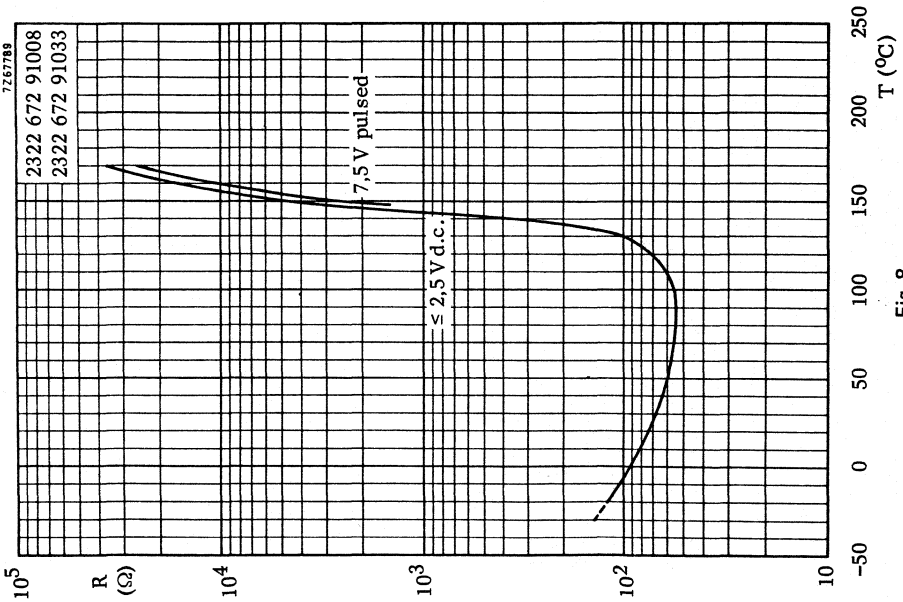

Fig. 8.



2322 672 91002  
to  
2322 672 91035

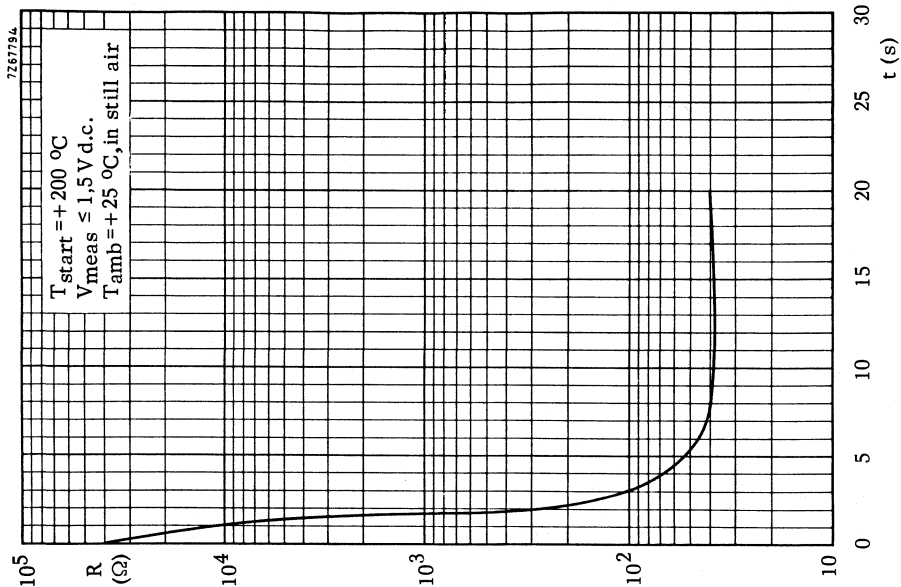

Fig. 11 Typical resistance/time (cooling) characteristic.

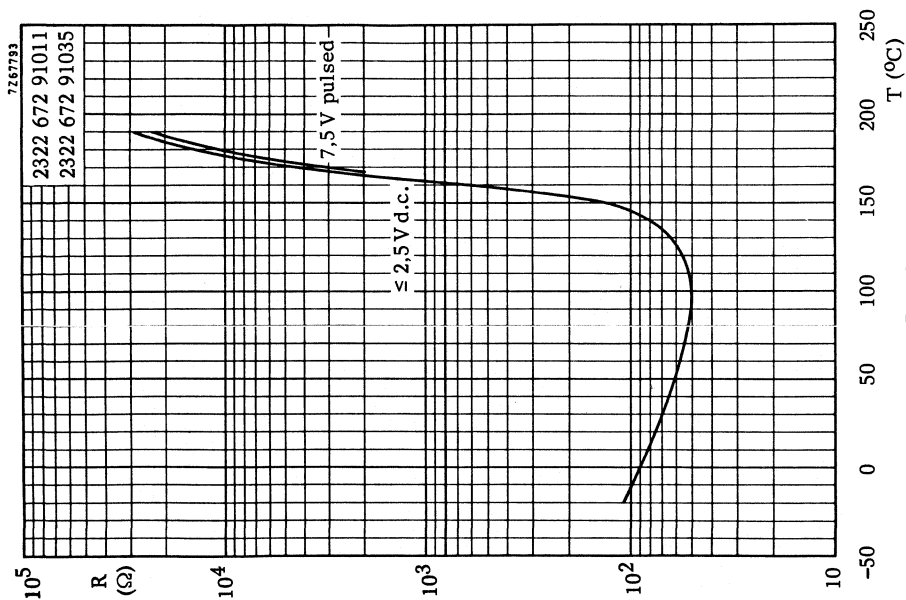

Fig. 10.

## PTC THERMISTORS

for motor protection

### QUICK REFERENCE DATA

Resistance value at $-20$ and $T_{ref} - 20$ °C	30 to 250 $\Omega$
Resistance value at $T_{ref} + 15$ °C, $V_{pulse} = 7,5$ V	> 4000 $\Omega$
Maximum voltage (d.c.)	15 V
Switch temperature, $T_s$	68 to 137 °C
Dissipation factor	$\approx 7$ mW/K
Operating temperature range at zero power at $V_{max}$	$-20$ to $T_{ref} + 30$ °C $-20$ to $T_{ref} + 15$ °C

### APPLICATION

These thermistors have been designed for use in transistorized circuits for the protection of electric motors against overheating. They are to be built into the windings of the stator (one PTC thermistor per phase).

### DESCRIPTION

The thermistors have a positive temperature coefficient. They consist of a disc with two tinned multi-strand copper wires insulated with PTFE material complying with the requirements of the ministry of aviation specification EL1930.

### MECHANICAL DATA

#### Outlines

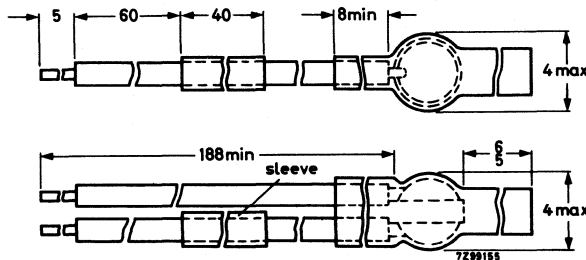

Fig. 1.

**Marking** The last five figures of the catalogue number are printed on the sleeve, e.g. PTC 92046.

**Mass** 1,6 g approximately

**Mounting** In motor windings; connections to be soldered or clamped.

### PACKAGING

200 thermistors in a cardboard box.

2322 672 92045  
to  
2322 672 92053

### ELECTRICAL DATA

$T_{ref}$ °C (note 1)	$T_s$ °C	temperature coefficient %/K	voltage dependence $\beta$	balance voltage $V_{dc}$	catalogue number
80	68	18	0,32	19	2322 672 92045
90	75	21	0,40	27	92046
100	88	31	0,36	6,5	92047
110	99	33	0,35	17	92048
120	113	38	0,36	11	92049
130	123	27	0,38	34	92051
140	130	33	0,34	13	92052
150	137	33	0,35	20	92053

		notes
Resistance between $-20$ and $T_{ref} - 20$ °C	30 to 250 $\Omega$	2
Resistance at $T_{ref} - 5$ °C	< 550 $\Omega$	2
Resistance at $T_{ref} + 5$ °C	> 1330 $\Omega$	
Resistance at $T_{ref} + 15$ °C, $V_{pulse} = 7,5$ V	> 4000 $\Omega$	3
Dissipation factor	$\approx 7$ mW/K	4
Heat capacity	$\approx 0,1$ J/K	4
Thermal time constant	$\approx 14$ s	4
Response time	$\leq 8$ s	5
Operating temperature range		
at zero power	$-20$ to $+T_{ref} + 30$ °C	
at $V_{max}$	$-20$ to $+T_{ref} + 15$ °C	
Maximum voltage (d.c.)	15 V	
Dielectric withstanding voltage (r.m.s.) between terminals and lead insulation	$\geq 2500$ V	
Insulation resistance between terminals and lead insulation	$\geq 100$ M $\Omega$	

### Notes

- $T_{ref}$  is the temperature at which the thermistor has to make the protective system operative.
- Measuring voltage not exceeding 1,5 V (d.c.) to avoid internal heating.
- Measurements made without internal heating occurring.
- Measurements made with specimen in phosphor-bronze clips, in still air.
- Response time is the time in which the thermistor-body temperature rises to 63,2% of the difference between initial and final body temperature, when the thermistor is subjected to a step function change in ambient temperature.  
Initial temperature: 25 °C (air).  
Final temperature:  $T_{ref} + 15$  °C (silicon oil MS 200/50).

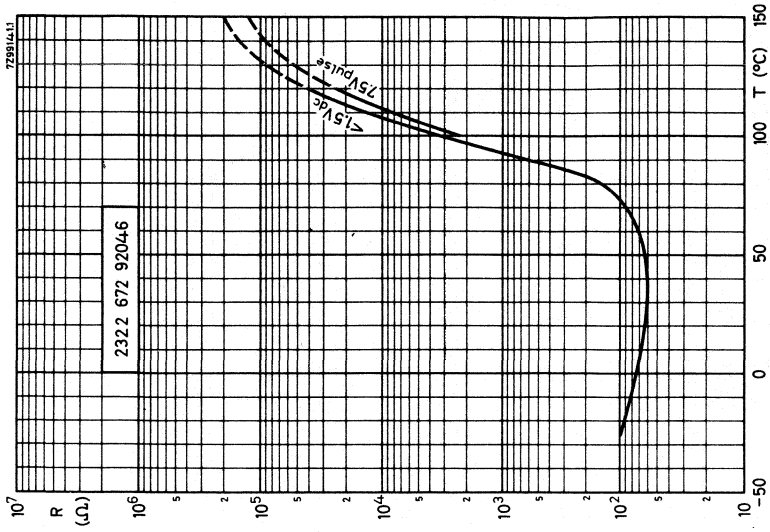

Fig. 3.

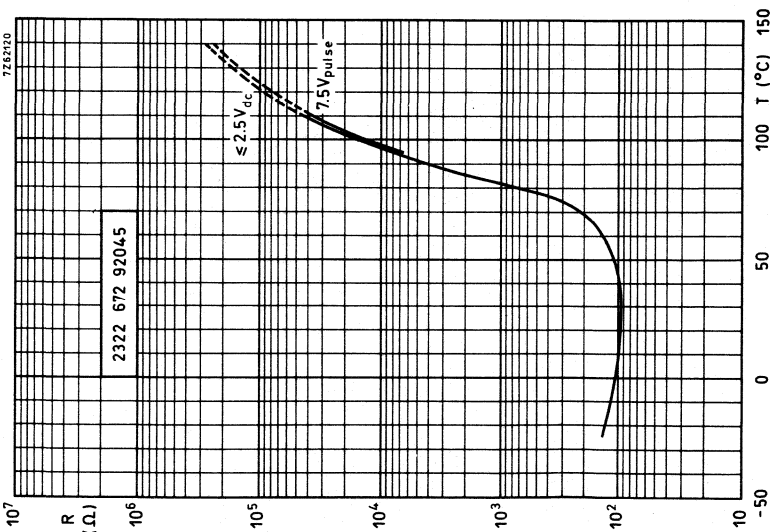

Fig. 2.

Typical resistance/temperature characteristics.



2322 672 92045  
to  
2322 672 92053

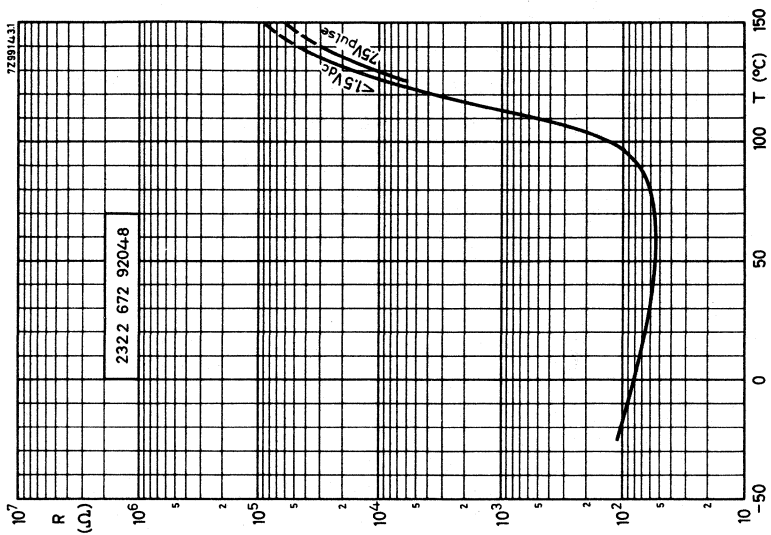

Fig. 5.

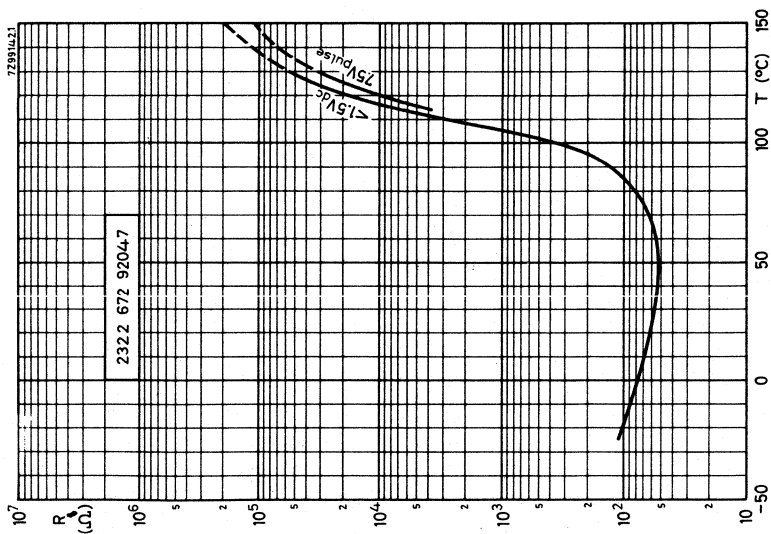

Fig. 4.

Typical resistance/temperature characteristics.



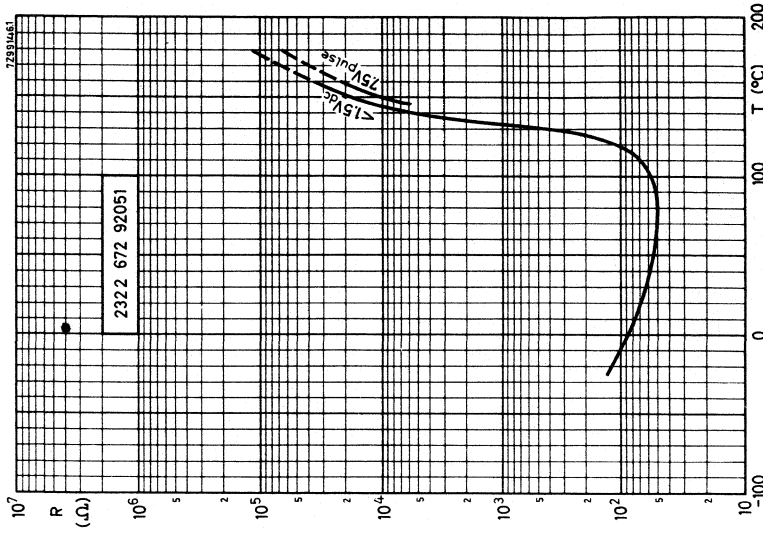

Fig. 7.

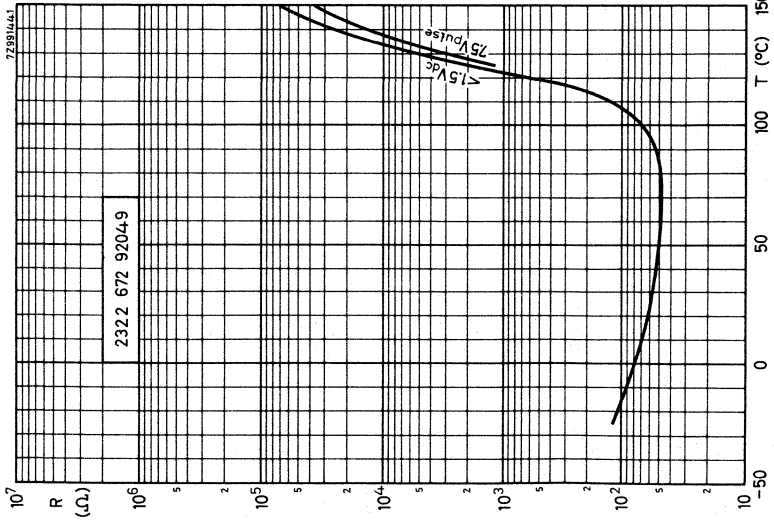

Fig. 6.

Typical resistance/temperature characteristics.



2322 672 92045  
to  
2322 672 92053

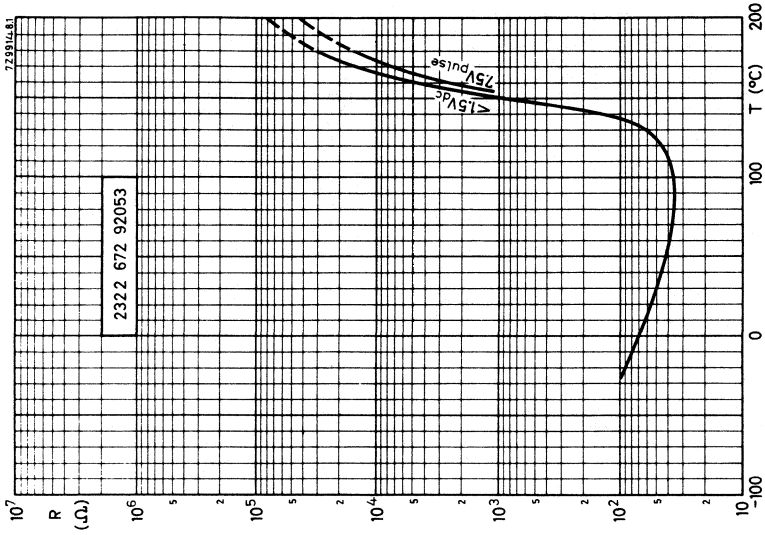

Fig. 9.

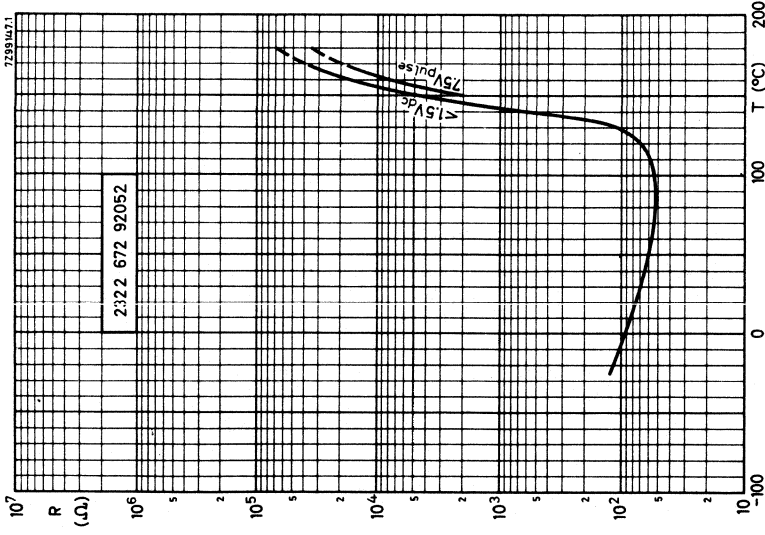

Fig. 8.

Typical resistance/temperature characteristics.



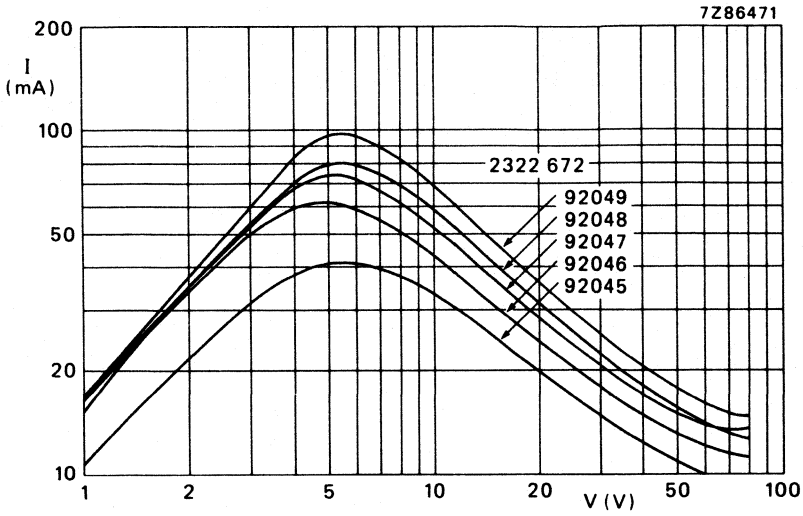

Fig. 10.

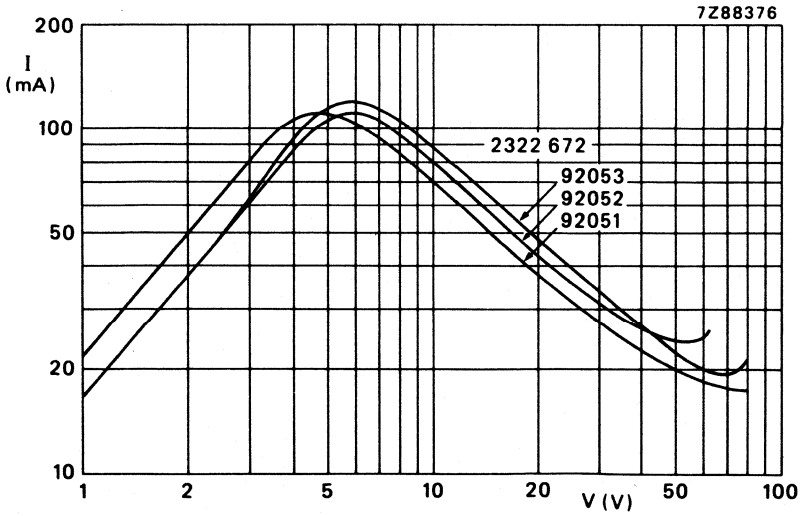

Fig. 11.

Typical voltage/current characteristics.



## PTC THERMISTOR

## QUICK REFERENCE DATA

Resistance value at + 25 °C	115 ± 25 Ω
Resistance value at + 155 °C, $V_{\text{pulse}} = 33 \text{ V}$	min. 15 kΩ
Switch temperature	≈ +97 °C
Temperature coefficient	min. 10%/K
Maximum voltage (d.c.)	33 V
Operating temperature range	
at zero power	-25 to + 155 °C
at maximum voltage	+ 5 to + 55 °C

## APPLICATION

As current stabilizer for compensation of variations in telephone line resistance.

## DESCRIPTION

Disc with positive temperature coefficient, mounted between pressure contacts to ensure a long cycle life. Provided with two silvered pins for mounting in a printed-wiring board. Plastic encapsulation.

## MECHANICAL DATA

## Outlines

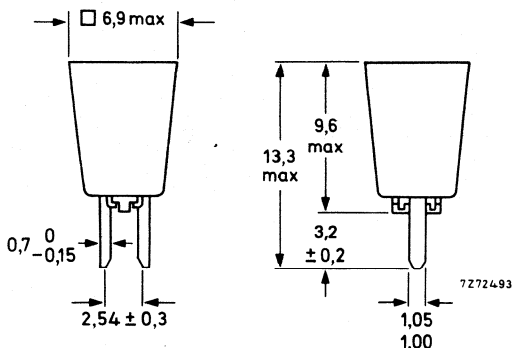

Fig. 1.

## PACKAGING

5000 thermistors in a cardboard box (containing 10 foam plastic trays).

**Marking**

Manufacturer's identification symbol and the letters TPE, representing the model, are moulded in the top of the cap.

**Mass** 0,4 g approximately

**Mounting** to be soldered onto a printed-wiring board

**Robustness of terminations**

**Tensile strength** 10 N

**Soldering**

**Solderability** max. 240 °C, max. 4 s

**Resistance to heat** max. 265 °C, max. 11 s

**Vibration** in accordance with CCTU 01-01A fasc. 16 A severity 55 A

**Impact**

**Free fall** 1000 mm

**Inflammability** unflammable

**ELECTRICAL DATA**

The values in the table without further indication are approximate values.

**Resistance**

at +25 °C

115 ± 25 Ω

at +97 °C

max. 600 Ω

at +155 °C,  $V_{\text{pulse}} = 33 \text{ V}$

min. 15 000 Ω

**Switch temperature**

+97 °C

**Temperature coefficient**

min. +10%/K

**Operating temperature range**

at zero power

-25 to +155 °C

at maximum voltage

+5 to +55 °C

**Voltage dependence at +155 °C**

0,29

**Maximum voltage (d.c.)**

33 V

Maximum dielectric withstanding voltage (r.m.s.) between terminals and capsule

500 V

Insulation resistance between terminals and capsule at 100 V d.c.

min. 10 MΩ

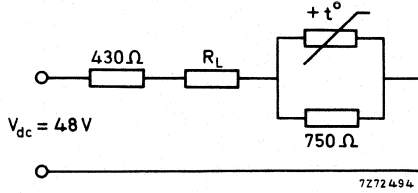

Fig. 2 Line resistance ( $R_L$ ) compensation.

Initial current of +5 °C and $R_L = 0$	min. 75 mA
	max. 95 mA
Current after 10 s at +5 °C and $R_L = 0$	max. 60 mA
Initial current at +55 °C and $R_L = 0$	min. 85 mA
	max. 105 mA
Current after 10 s at +5 °C and $R_L = 0$	max. 55 mA

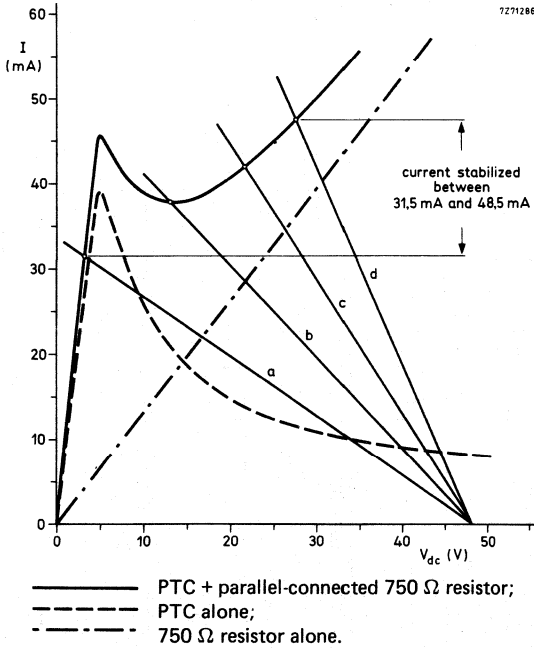

Fig. 3 (a)  $R_L = 1000 \Omega$ ; (c)  $R_L = 200 \Omega$ ;  
 (b)  $R_L = 500 \Omega$ ; (d)  $R_L = 0 \Omega$ .

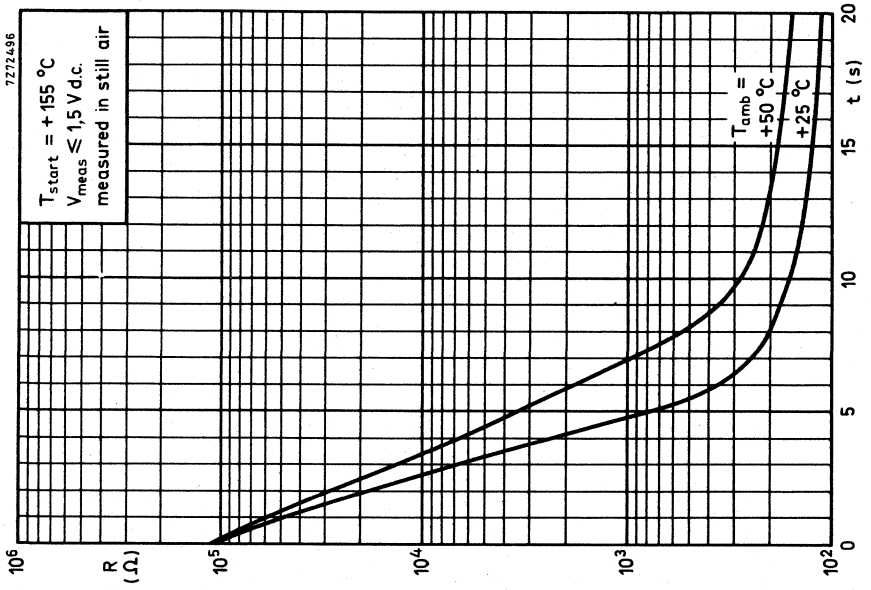

Fig. 5 Typical resistance/time (cooling) characteristics.

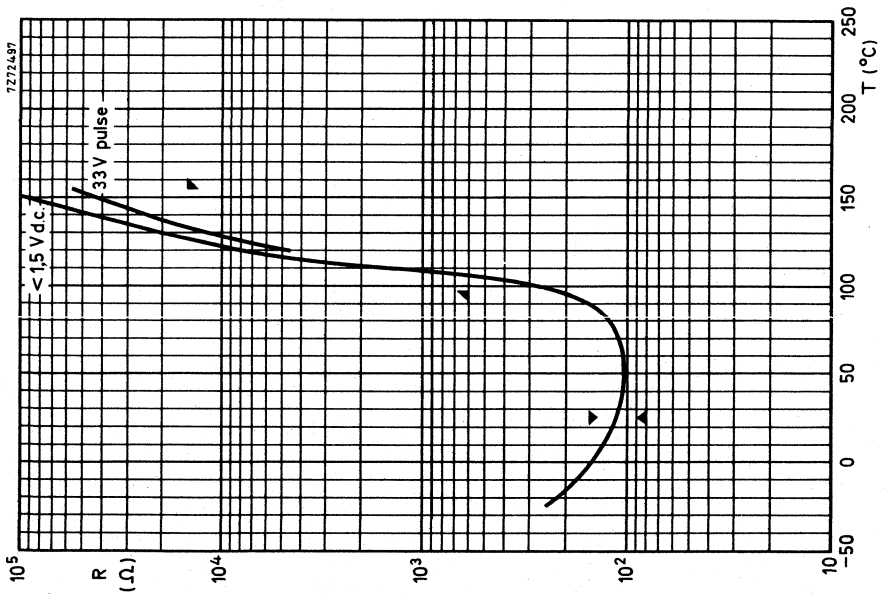

Fig. 4 Typical resistance/temperature characteristics.

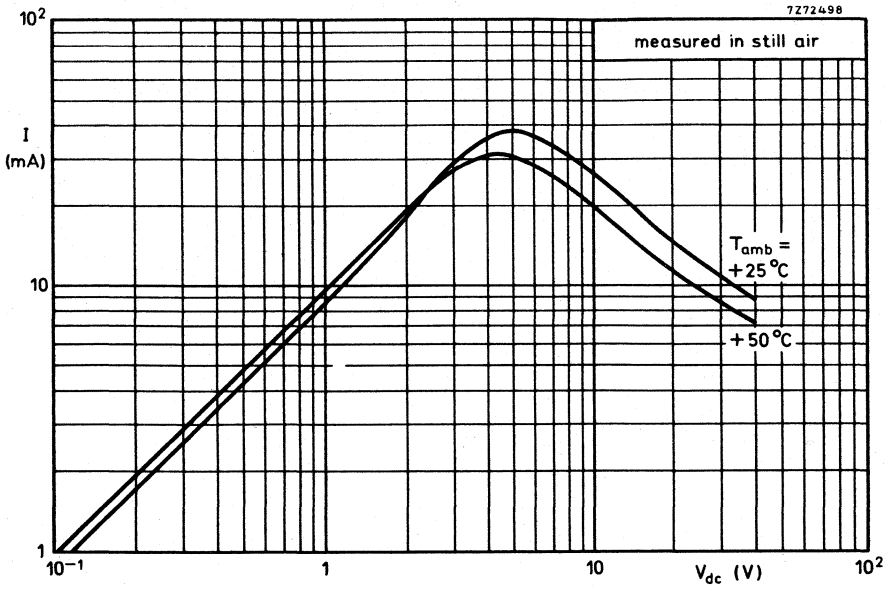

Fig. 6 Typical voltage/current characteristics.

**Note:**

Figs 5, 6 and 7 are measured with the PTC mounted on a printed-wiring board.

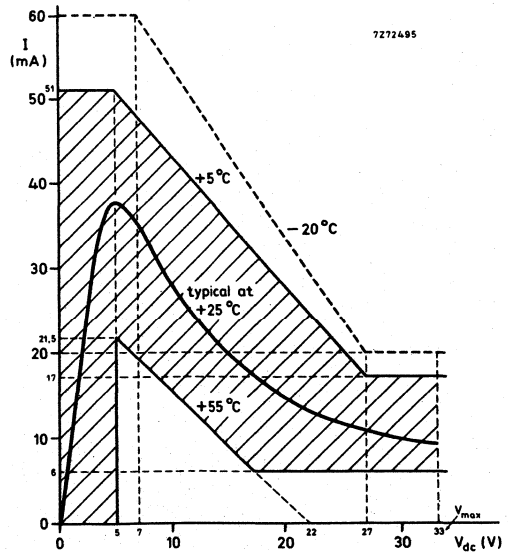

Fig. 7 Area of current/voltage characteristics.





## PTC THERMISTORS for motor start

### QUICK REFERENCE DATA

<b>Resistance value</b>	
at T = +25 °C, 100 V pulsed	8,75 to 17,5 Ω
at T = +70 °C, 100 V pulsed	7,25 to 14,5 Ω
at T = +115 °C, 100 V pulsed	≤ 30 Ω
<b>Switch temperature</b>	
	120 ± 10 °C
<b>Maximum voltage (r.m.s.)</b>	
	300 V
<b>Operating ambient temperature range</b>	
at zero power	-40 to +125 °C
at maximum voltage	0 to +80 °C

### APPLICATION

Motor start.

### DESCRIPTION

Disc thermistor with positive temperature coefficient; type 2322 678 93002 is a bare disc, type 2322 678 93001 is mounted in a plastic housing with stainless steel connectors.

### MECHANICAL DATA

#### Outlines

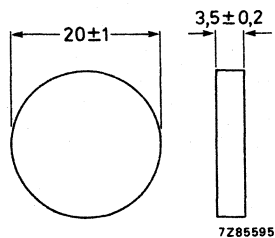

Fig. 1 Type 2322 678 93002.

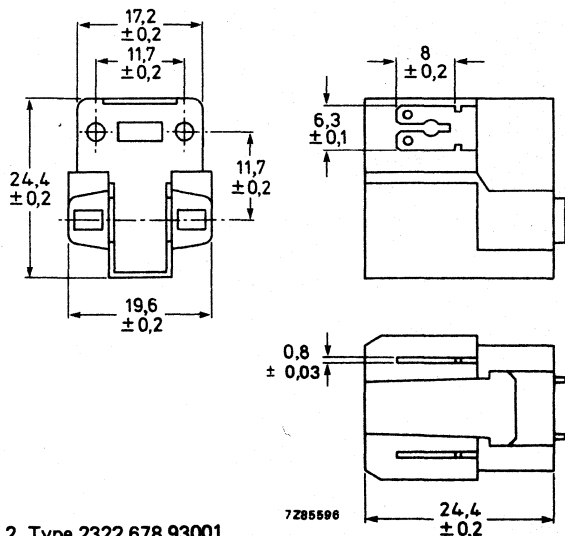

Fig. 2 Type 2322 678 93001.

	type	2322 678 93001	2322 678 93002	
Mass	≈	14,5	5,7	g
Mounting		plugged	clamped	
<b>Robustness of terminations</b>				
Tensile strength				
male		60 N	—	
female		55 N	—	
<b>Impact</b>				
Free fall		1000	200	mm
Inflammability		self-extinguishing	uninflammable	

#### PACKAGING

Type 2322 678 93001: 100 thermistors on preformed polyesterene sheets.

Type 2322 678 93002: 100 thermistors in a cardboard box.

#### ELECTRICAL DATA

##### Resistance\*

at +25 °C, 100 V pulsed	8,75 to 17,5 Ω
at +70 °C, 100 V pulsed	7,25 to 14,5 Ω
at +115 °C, 100 V pulsed	≤ 30 Ω

Switch temperature 120 ± 10 °C

Maximum voltage (r.m.s.) with series resistor of 33 Ω 300 V

Maximum static voltage (r.m.s.) at 25 °C, with a series resistor of 1000 Ω, type 2322 678 93002 only 455 V

Maximum residual current (r.m.s.), after 5 min at +80 °C, at 300 V (r.m.s.) 9,5 mA

Maximum inrush current (r.m.s.) with a minimum series resistor of 27 Ω, from 0 to +80 °C 8 A

Minimum inrush current (r.m.s.) after 120 ms at +80 °C at 242 V (r.m.s.) with a series resistor of 27 Ω 5,7 A

Heat capacity ≈ 5 J/K

Thermal time constant by cooling (2322 678 93001) ≈ 285 s

Dissipation factor at max. voltage (2322 678 93001) ≈ 17,4 mW/K

##### Operating ambient temperature range

at zero power -40 to +125 °C

at maximum voltage 0 to +80 °C

\* Measured without internal heating.

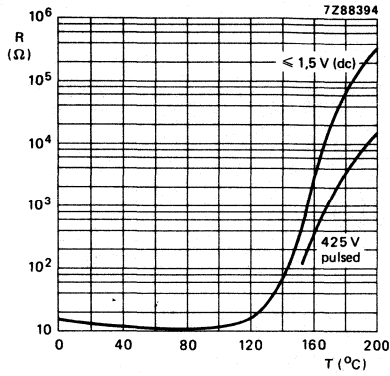

Fig. 3 Typical resistance/temperature characteristics.

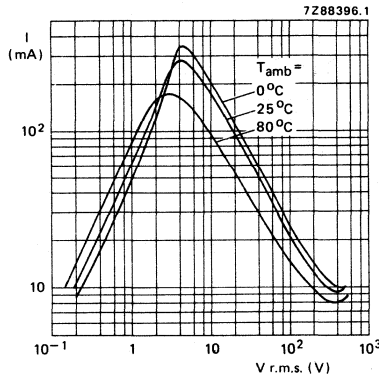

Fig. 4 Typical voltage/current characteristics; type 2322 678 93001.

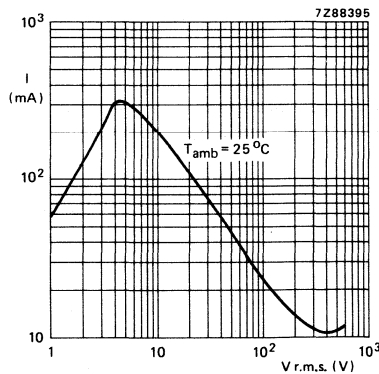

Fig. 5 Typical voltage/current characteristic; type 2322 678 93002.



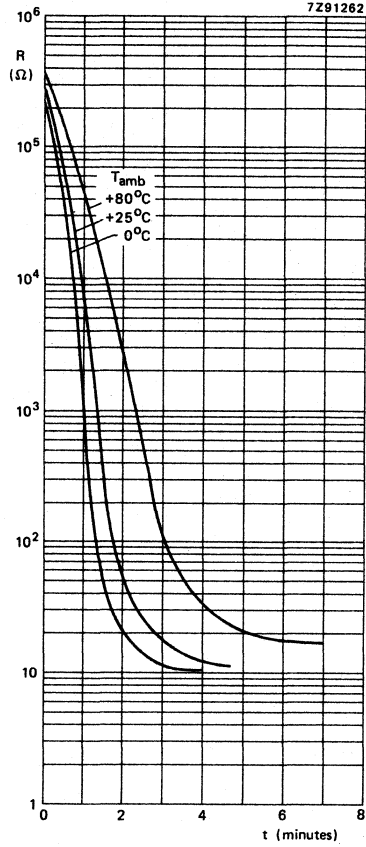

Fig. 6 Typical resistance/time (cooling) characteristics of 2322 678 93001, measured in still air in 3-pin connector.

## DEVELOPMENT SAMPLE DATA

This information is derived from development samples made available for evaluation. It does not necessarily imply that the device will go into regular production.

2322 680 00001

## PTC THERMISTORS FOR HEATING

### QUICK REFERENCE DATA

Voltage range, r.m.s., 50 or 60 Hz	100 to 265 V
Temperature after 20 min at 220 V r.m.s.	$160 \pm 12$ °C
Maximum time to reach 130 °C at 220 V r.m.s.	5 min
Maximum inrush power at 265 V r.m.s.	1 kW
Operating temperature range	
at zero power	-25 to +85 °C
at maximum voltage	0 to 55 °C

### APPLICATION

As heating element for general use.

### DESCRIPTION

Encapsulated single insulated thermistor with positive temperature coefficient and provided with two single-core insulated silver plated copper wires.

### MECHANICAL DATA

Outlines

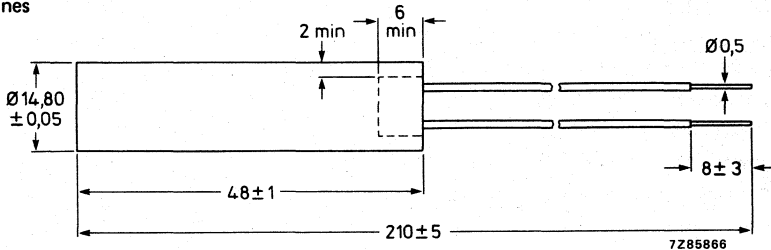

Fig. 1.

**PACKAGING**

500 thermistors in a cardboard box.

A label on the cardboard box is provided with following details:

Manufacturer's name

Voltage range

Operating power after 20 min – UL emblem

Group name

Catalogue number

Quantity, reference, manufacturing date (year – month)

**Marking** The thermistors are tan coloured; the connecting leads are blue.

**Connections** PTFE wire according to Thermax wire 24-XTO-124 UL style 1180.

**Mass** 20 g approximately

**Mounting** In any position by soldering or clamping. Suitable for mounting in a tube with a diameter of 14,86 + 0,05 mm.

**Robustness of terminations**

**Tensile strength** 10 N

**Bending** 5 N

**Solderability** max. 240 °C, max. 6 s

**Impact**

**Free fall** 1000 mm

**Inflammability** unflammable, in accordance with IEC publication 695-2-2 of 1980.

**ELECTRICAL DATA**

<b>Voltage range, r.m.s., 50 or 60 Hz</b>	100 to 265 V
<b>Temperature after 20 min at 220 V r.m.s.</b>	160 ± 12 °C
<b>Maximum time to reach 130 °C at 220 V r.m.s.</b>	5 min
<b>Maximum inrush power at 265 V r.m.s.</b>	1 kW
<b>Operating power after 20 min at 220 V r.m.s.</b>	~ 13 W
<b>Minimum dielectric withstanding voltage, r.m.s.</b>	4 kV
<b>Operating temperature range</b>	
at zero power	-25 to + 85 °C
at maximum voltage	0 to + 55 °C

## DEVELOPMENT SAMPLE DATA

This information is derived from development samples made available for evaluation. It does not necessarily imply that the device will go into regular production.

2322 680 03001

## PTC THERMISTORS FOR HEATING

### QUICK REFERENCE DATA

Voltage range, r.m.s., 50 or 60 Hz	100 to 265 V
Temperature after 20 min at 220 V r.m.s.	$160 \pm 12$ °C
Maximum time to reach 130 °C at 220 V r.m.s.	5 min
Maximum inrush power at 265 V r.m.s.	1 kW
Operating temperature range	
at zero power	-25 to +85 °C
at maximum voltage	0 to +55 °C

### APPLICATION

As heating element for general use.

### DESCRIPTION

Encapsulated single insulated thermistor with positive temperature coefficient and provided with two single-core insulated silver plated copper wires.

### MECHANICAL DATA

Outlines

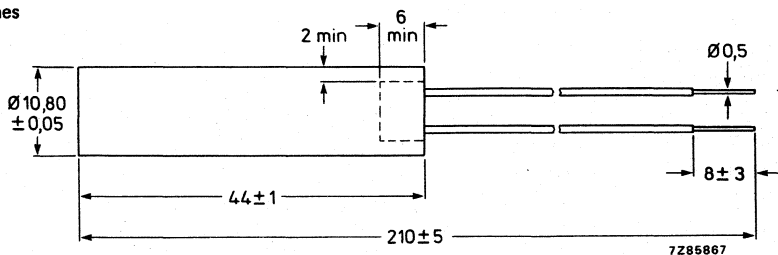

Fig. 1.

**PACKAGING**

1000 thermistors in a cardboard box.

A label on the cardboard box is provided with the following details:

Manufacturer's name

Voltage range

Operating power after 20 min – UL emblem

Group name

Catalogue number

Quantity, reference, manufacturing date (year – month)

Marking	The thermistors are tan coloured. the connecting leads are white
Connections	PTFE wire according to Thermax wire 24-XTO-124 UL style 1180.
Mass	10 g approximately
Mounting	In any position by soldering or clamping. Suitable for mounting in a tube with a diameter of 10,86 + 0,05 mm.
Robustness of terminations	
Tensile strength	10 N
Bending	5 N
Solderability	max. 240 °C, max. 6 s
Impact	
Free fall	1000 mm
Inflammability	uninflammable, in accordance with IEC publication 695-2-2 of 1980

**ELECTRICAL DATA**

Voltage range, r.m.s., 50 or 60 Hz	100 to 265 V
Temperature after 20 min. at 220 V r.m.s.	160 ± 12 °C
Maximum time to reach 130 °C at 220 V r.m.s.	5 min
Maximum inrush power at 265 V r.m.s.	1 kW
Operating power after 20 min. at 220 V r.m.s.	~ 10 W
Minimum dielectric withstanding voltage, r.m.s.	4 kV
Operating temperature range	
at zero power	-25 to + 85 °C
at maximum voltage	0 to + 55 °C



## DEVELOPMENT SAMPLE DATA

This information is derived from development samples made available for evaluation. It does not necessarily imply that the device will go into regular production.

2322 680 04001

## PTC THERMISTORS FOR HEATING

### QUICK REFERENCE DATA

Voltage range, r.m.s., 50 or 60 Hz	100 to 265 V
Temperature after 20 min at 220 V r.m.s.	$215 \pm 12$ °C
Maximum time to reach 170 °C at 220 V r.m.s.	5 min
Maximum inrush power at 265 V r.m.s.	1 kW
Operating temperature range	
at zero power	-25 to +85 °C
at maximum voltage	0 to +55 °C

### APPLICATION

As heating element for general use.

### DESCRIPTION

Encapsulated single insulated thermistor with positive temperature coefficient and provided with two single-core insulated silver plated copper wires.

### MECHANICAL DATA

Outlines

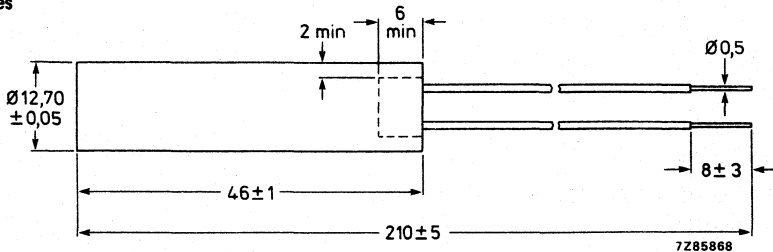

Fig. 1.

**PACKAGING**

1000 thermistors in a cardboard box.

A label on the cardboard box is provided with the following details:

Manufacturer's name

Voltage range

Operating power after 20 min – UL emblem

Group name

Catalogue number

Quantity, reference, manufacturing date (year – month)

Marking The thermistors are red coloured; the connecting leads are red.

Connections PTFE wire according to Thermax wire 24-XTO-124 UL style 1180.

Mass 15 g approximately

Mounting In any position by soldering or clamping. Suitable for mounting in a tube with a diameter of  $12,76 + 0,05$  mm.

Robustness of terminations

Tensile strength 10 N

Bending 5 N

Solderability max. 240 °C, max. 6 s

Impact

Free fall 1000 mm

Inflammability uninflamability, in accordance with IEC publication 695-2-2 of 1980

**ELECTRICAL DATA**

Voltage range, r.m.s., 50 or 60 Hz	100 to 265 V
Temperature after 20 min. at 220 V r.m.s.	$215 \pm 12$ °C
Maximum time to reach 170 °C at 220 V r.m.s.	5 min
Maximum inrush power at 265 V r.m.s.	1 kW
Operating power after 20 min. at 220 V r.m.s.	~ 18 W
Minimum dielectric withstanding voltage, r.m.s.	4 kV
Operating temperature range	
at zero power	-25 to + 85 °C
at maximum voltage	0 to + 55 °C

## DEVELOPMENT SAMPLE DATA

This information is derived from development samples made available for evaluation. It does not necessarily imply that the device will go into regular production.

2322 680 04002

## PTC THERMISTORS FOR HEATING

### QUICK REFERENCE DATA

Voltage range, r.m.s., 50 or 60 Hz	100 to 145 V
Temperature after 20 min at 120 V r.m.s.	$215 \pm 12$ °C
Maximum time to reach 170 °C at 120 V r.m.s.	5 min
Maximum inrush power at 145 r.m.s.	1 kW
Operating temperature range	
at zero power	-25 to + 85 °C
at maximum voltage	0 to + 55 °C

### APPLICATION

As heating element for general use.

### DESCRIPTION

Encapsulated single insulated thermistor with positive temperature coefficient and provided with two single-core insulated silver plated copper wires.

### MECHANICAL DATA

Outlines

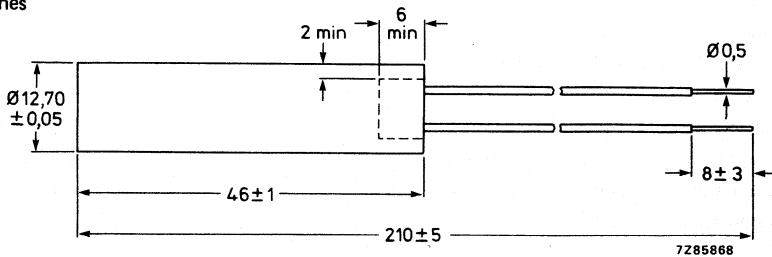

Fig. 1.

**PACKAGING**

1000 thermistors in a cardboard box.

A label on the cardboard box is provided with the following details:

Manufacturer's name

Voltage range

Operating power after 20 min – UL emblem

Group name

Catalogue number

Quantity, reference, manufacturing date (year – month)

**Marking** The thermistors are red coloured; the connecting leads are red and black.  
**Connections** PTFE wire according to Thermax wire 24-XTO-124 UL style 1180.  
**Mass** 15 g approximately  
**Mounting** In any position by soldering or clamping. Suitable for mounting in a tube with a diameter of 12,76 + 0,05 mm.

**Robustness of terminations**

**Tensile strength** 10 N

**Bending** 5 N

**Solderability** max. 240 °C, max. 6 s

**Impact**

**Free fall** 1000 mm

**Inflammability** unflammable, in accordance with IEC publication 695-2-2 of 1980

**ELECTRICAL DATA**

<b>Voltage range, r.m.s., 50 or 60 Hz</b>	100 to 145 V
<b>Temperature after 20 min. at 120 V r.m.s.</b>	215 ± 12 °C
<b>Maximum time to reach 170 °C at 120 V r.m.s.</b>	5 min
<b>Maximum inrush power at 145 V r.m.s.</b>	1 kW
<b>Operating power after 20 min. at 120 V r.m.s.</b>	~ 18 W
<b>Minimum dielectric withstanding voltage, r.m.s.</b>	4 kV
<b>Operating temperature range</b>	
at zero power	-25 to +85 °C
at maximum voltage	0 to +55 °C

## DEVELOPMENT SAMPLE DATA

This information is derived from development samples made available for evaluation. It does not necessarily imply that the device will go into regular production.

2322 680 04003

## PTC THERMISTORS FOR HEATING

### QUICK REFERENCE DATA

Voltage range, r.m.s., 50 or 60 Hz	100 to 265 V
Temperature after 20 min at 220 V r.m.s.	$160 \pm 12$ °C
Maximum time to reach 130 °C at 220 V r.m.s.	5 min
Maximum inrush power at 265 V r.m.s.	1 kW
Operating temperature range	
at zero power	-25 to + 85 °C
at maximum voltage	0 to + 55 °C

### APPLICATION

As heating element for general use.

### DESCRIPTION

Encapsulated single insulated thermistor with positive temperature coefficient and provided with two single-core insulated silver plated copper wires.

### MECHANICAL DATA

Outlines

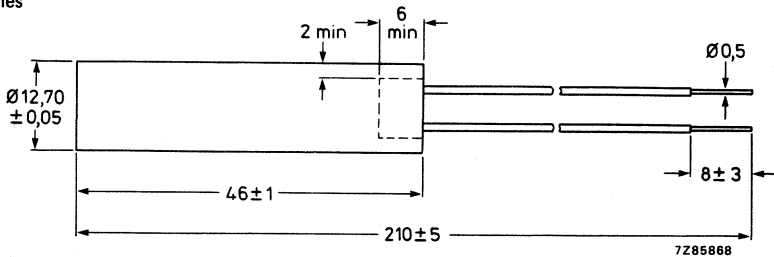

Fig. 1.

**PACKAGING**

1000 thermistors in a cardboard box.

A label on the cardboard box is provided with the following details:

Manufacturer's name

Voltage range

Operating power after 20 min – UL emblem

Group name

Catalogue number

Quantity, reference, manufacturing date (year – month)

Marking            The thermistors are tan coloured; the connecting leads are red.

Connections      PTFE wire according to Thermax wire 24-XTO-124 UL style 1180.

Mass                15 g approximately

Mounting          In any position by soldering or clamping. Suitable for mounting in a tube with a diameter of 12,76 + 0,05 mm.

Robustness of terminations

Tensile strength    10 N

Bending            5 N

Solderability        max. 240 °C, max. 6 s

Impact

Free fall            1000 mm

Inflammability    unflammable, in accordance with IEC publication 695-2-2 of 1980

**ELECTRICAL DATA**

Voltage range, r.m.s., 50 or 60 Hz.	100 to 265 V
Temperature after 20 min. at 220 V r.m.s.	160 ± 12 °C
Maximum time to reach 130 °C at 220 V r.m.s.	5 min
Maximum inrush power at 265 V r.m.s.	1 kW
Operating power after 20 min. at 220 V r.m.s.	~ 13 W
Minimum dielectric withstanding voltage, r.m.s.	4 kV
Operating temperature range	
at zero power	-25 to + 85 °C
at maximum voltage	0 to + 55 °C

## DEVELOPMENT SAMPLE DATA

This information is derived from development samples made available for evaluation. It does not necessarily imply that the device will go into regular production.

2322 680 04004

## PTC THERMISTORS FOR HEATING

### QUICK REFERENCE DATA

Voltage range, r.m.s., 50 or 60 Hz	100 to 145 V
Temperature after 20 min at 120 V r.m.s.	$160 \pm 12$ °C
Maximum time to reach 130 °C at 120 V r.m.s.	5 min
Maximum inrush power at 145 V r.m.s.	1 kW
Operating temperature range	
at zero power	-25 to +85 °C
at maximum voltage	0 to +55 °C

### APPLICATION

As heating element for general use.

### DESCRIPTION

Encapsulated single insulated thermistor with positive temperature coefficient and provided with two single-core insulated silver plated copper wires.

### MECHANICAL DATA

Outlines

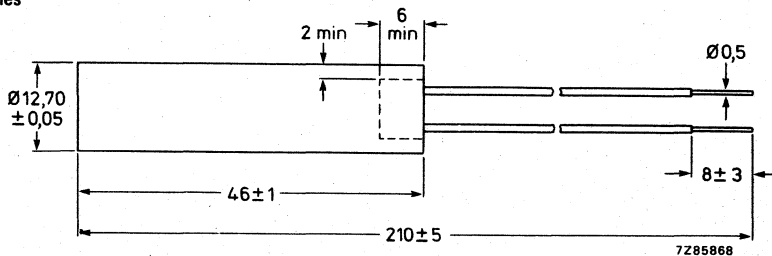

Fig. 1.

**PACKAGING**

1000 thermistors in a cardboard box.

A label on the cardboard box is provided with the following details:

Manufacturer's name

Voltage range

Operating power after 20 min – UL emblem

Group name

Catalogue number

Quantity, reference, manufacturing date (year – month)

**Marking** The thermistors are tan coloured; the connecting leads are red and black.  
**Connections** PTFE wire according to Thermax wire 24-XTO-124 UL style 1180.  
**Mass** 15 g approximately  
**Mounting** In any position by soldering or clamping. Suitable for mounting in a tube with a diameter of 12,76 + 0,05 mm.

**Robustness of terminations**

**Tensile strength** 10 N

**Bending** 5 N

**Solderability** max. 240 °C, max. 6 s

**Impact**

**Free fall** 1000 mm

**Inflammability** unflamable, in accordance with IEC publication 695-2-2 of 1980

**ELECTRICAL DATA**

<b>Voltage range, r.m.s., 50 or 60 Hz</b>	100 to 145 V
<b>Temperature after 20 min. at 120 V r.m.s.</b>	160 ± 12 °C
<b>Maximum time to reach 130 °C at 120 V r.m.s.</b>	5 min
<b>Maximum inrush power at 145 V r.m.s.</b>	1 kW
<b>Operating power after 20 min. at 120 V r.m.s.</b>	~ 13 W
<b>Minimum dielectric withstanding voltage, r.m.s.</b>	4 kV
<b>Operating temperature range</b>	
at zero power	-25 to +85 °C
at maximum voltage	0 to +55 °C



## PTC HEATING ELEMENT

### QUICK REFERENCE DATA

Voltage range (r.m.s.)	100 to 265 V
Maximum inrush power at 265 V	1 kW
Operating power at 220 V after 20 min	19 W
Time to reach + 180 °C at 220 V	< 5 min
Operating temperature range at zero power	-25 to +85 °C
at maximum voltage	0 to +55 °C

### APPLICATION

Designed for applications that require high initial dissipation followed by moderate continuous dissipation, such as hot melt glue guns.

### DESCRIPTION

Insulated heating element consisting of a PTC thermistor moulded in a silicone rubber tube with two insulated silver plated copper wires.

### MECHANICAL DATA

#### Outlines

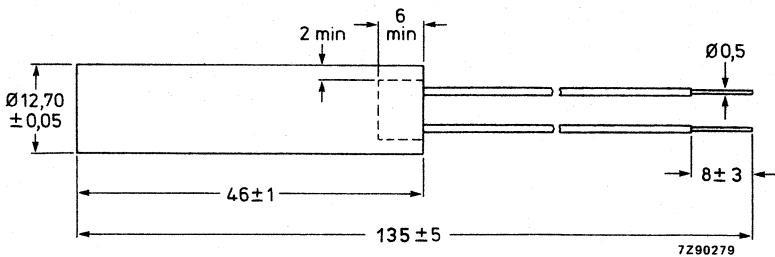

Fig. 1.

<b>Marking</b>	Connecting leads: red (twice)
<b>Mounting</b>	In any position by soldering or clamping
<b>Robustness of terminations</b>	
Tensile strength	10 N
Bending	5 N
<b>Soldering</b>	
Solderability	max. 240 °C, max. 6 s
<b>Impact</b>	
Free fall	1000 mm

**PACKAGING**

600 thermistors in a cardboard box

**ELECTRICAL DATA**Measurements made in still air at an ambient temperature of  $+23 \pm 1$  °C

Voltage range (r.m.s.)	100 to 265 V
Maximum inrush power at 265 V	1 kW
Operating power at 220 V, after 20 min	19 W approx.
Time to reach +180 °C at 220 V	< 5 minutes
Temperature on standard test mounting after 20 min at 220 V	220 $\pm$ 10 °C
Operating temperature range	
at zero power	-25 to +85 °C
at maximum voltage	0 to +55 °C

## PTC HEATING ELEMENT

### QUICK REFERENCE DATA

Voltage range (r.m.s.)	100 to 265 V
Maximum inrush power at 220 V	500 W
Operating power at 220 V after 20 min.	17 W $\pm$ 20%
Time to reach + 130 °C at 220 V	max. 7 min.
Ambient temperature range at zero power and at maximum voltage	-25 to +60 °C

### APPLICATION

Designed for applications that require high initial dissipation followed by moderate continuous dissipation, such as hair curling tongs.

### DESCRIPTION

Double insulated heating element consisting of a PTC thermistor moulded in a silicone rubber tube and two insulated copper wires which are partly covered by a silicone rubber sleeve.

### MECHANICAL DATA

Dimensions in mm

#### Outlines

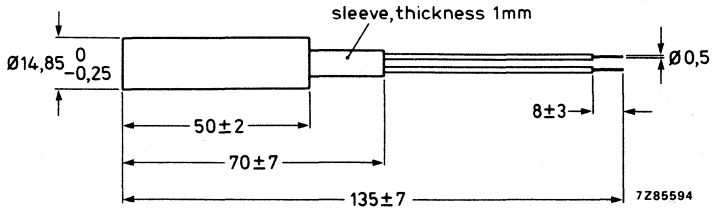

Fig. 1.

<b>Marking</b>	None
<b>Mass</b>	28 g approximately
<b>Mounting</b>	In any position by soldering or clamping
<b>Robustness of terminations</b>	
Tensile strength	20 N
Bending	5 N
Torsion	3 rotations of 360°
<b>Soldering</b>	
Solderability	max. 240 °C, max. 6 s
<b>Impact</b>	
Free fall	1000 mm

→ **PACKAGING**

500 thermistors in a cardboard box.

**ELECTRICAL DATA**

Measurements made in still air at an ambient temperature of  $+23 \pm 1$  °C

Voltage range (r.m.s.) 100 to 265 V

Maximum inrush power at 220 V (r.m.s.) 500 W

Operating power at 280 V (r.m.s.), after 20 min. 17 W  $\pm$  20%

Time to reach +130 °C at 220 V max. 7 min.

Temperature on standard test mounting after 20 min.

at 120 V (r.m.s.)  $\approx$  177 °C

at 220 V (r.m.s.)  $+185 \pm 8$  °C

Dielectric withstanding voltage (r.m.s.) between terminals and an aluminium tube acting as outer electrode \*

after 48  $\pm$  0,5 h at 93  $\pm$  2% R.H. and min. 6 kV

32  $\pm$  1 °C, measured inside test chamber min. 5 kV

Insulation resistance between terminals and an aluminium tube acting as outer electrode, at 500 V (d.c.)

after 48  $\pm$  0,5 h at 93  $\pm$  2% R.H. and min. 10 M $\Omega$

32  $\pm$  1 °C, measured inside test chamber min. 10 M $\Omega$

Operating temperature range

at zero power and at maximum voltage  $-25$  to  $+60$  °C

\* The heating element contains 2 silicone rubber tubes. The inner tube has a min. dielectric withstanding voltage of 1,5 kV, the outer one (min. wall thickness 1 mm) of 2,5 kV. The test voltage is a voltage increasing at a rate of 500 V/s, the maximum voltage is applied for 1 min.

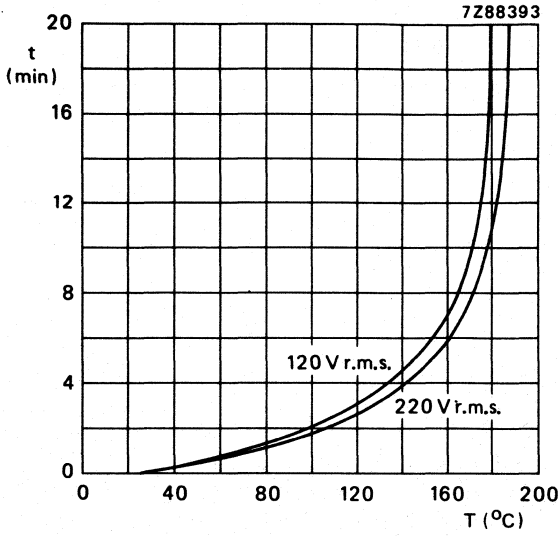

Fig. 2 Typical temperature/time stabilization characteristics.  
Measured in standard test mounting.  
 $T_{amb} = +23\text{ }^{\circ}\text{C}$ .





## PTC HEATING ELEMENT

### QUICK REFERENCE DATA

Voltage range (r.m.s.)	100 to 240 V
Maximum inrush power at 220 V	500 W
Operating power at 220 V after 20 min	15 W $\pm$ 20%
Time to reach + 130 °C at 220 V	max. 7 min
Ambient temperature range at zero power and at maximum voltage	-25 to + 60 °C

### APPLICATION

Designed for applications that require high initial dissipation followed by moderate continuous dissipation, such as hair curling tongs.

### DESCRIPTION

Double insulated heating element composed of a PTC thermistor moulded in a silicone rubber tube and two insulated solid copper wires which are partly covered by a silicone rubber sleeve.

### MECHANICAL DATA

#### Outlines

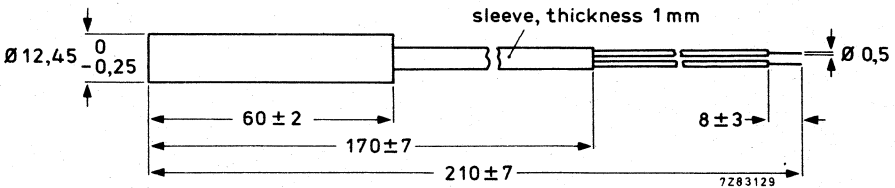

Fig. 1.

**Making**

PHILIPS, 2322 680 90047, 100-240 V, 15 W and batch no. on the body.

<b>Mass</b>	25 g approximately
<b>Mounting</b>	In any position by soldering or clamping
<b>Robustness of terminations</b>	
Tensile strength	20 N
Bending	5 N
Torsion	3 rotations of 360°
<b>Soldering</b>	
Solderability	max. 240 °C, max. 6 s
<b>Impact</b>	
Free fall	1830 mm

→ **PACKAGING**

600 thermistors in a cardboard box.

**ELECTRICAL DATA**

Measurements made in still air at an ambient temperature of  $+23 \pm 1$  °C.

Voltage range (r.m.s.)	100 to 240 V
Maximum inrush power at 220 V	500 W
Operating power at 220 V, after 20 min	15 W $\pm$ 20%
Time to reach +130 °C at 220 V	max. 7 min
Temperature on standard test mounting after 20 min	
at 120 V	min. 170 °C
at 220 V	+185 $\pm$ 8 °C
Dielectric withstanding voltage (r.m.s.) between terminals and an aluminium tube acting as outer electrode *	min. 6 kV
after 48 $\pm$ 0,5 h at 93 $\pm$ 2% R.H. and 32 $\pm$ 1 °C, measured inside test chamber	min. 5 kV
Insulation resistance between terminals and an aluminium tube acting as outer electrode	min. 10 M $\Omega$
after 48 $\pm$ 0,5 h at 93 $\pm$ 2% R.H. and 32 $\pm$ 1 °C, measured inside test chamber	min. 10 M $\Omega$
Ambient temperature range at zero power and at maximum voltage	-25 to +60 °C

\* The heating element contains 2 silicone rubber tubes. The inner tube has a min. dielectric withstanding voltage of 1,5 kV, the outer one (min. wall thickness 1 mm) of 2,5 kV. The test voltage is a voltage increasing at a rate of 500 V/s, the maximum voltage is applied for 1 min.



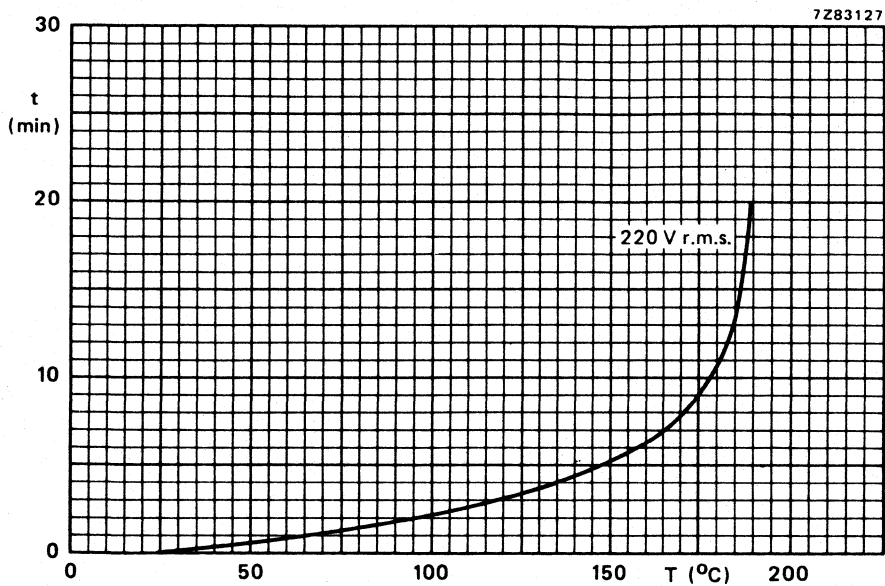

Fig. 2 Typical temperature versus time characteristics. Measured in standard test mounting.  $T_{\text{amb}} = +23^{\circ}\text{C}$ .





## PTC HEATING ELEMENT

### QUICK REFERENCE DATA

Voltage range (r.m.s.)	100 to 265 V
Maximum inrush power at 110 V (r.m.s.)	200 W
Operating power at 110 V after 20 min	15 W $\pm$ 20%
Time to reach + 130 °C at 110 V	max. 7 min
Ambient temperature range at zero power and at maximum voltage	-25 to +60 °C

### APPLICATION

Designed for applications that require high initial dissipation followed by moderate continuous dissipation, such as hair curling tongs.

### DESCRIPTION

Double insulated heating element composed of a PTC thermistor moulded in a silicone rubber tube and two insulated solid copper wires which are partly covered by a silicone rubber sleeve.

### MECHANICAL DATA

#### Outlines

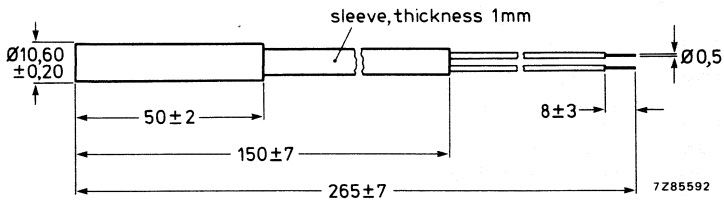

Fig. 1.

<b>Marking</b>	Connecting leads: one orange and one blue.
<b>Mass</b>	28 g approximately
<b>Mounting</b>	In any position by soldering or clamping
<b>Robustness of terminations</b>	
Tensile strength	20 N
Bending	5 N
Torsion	3 rotations of 360°
<b>Soldering</b>	
Solderability	max. 240 °C, max. 6 s
<b>Impact</b>	
Free fall	1000 mm

→ **PACKAGING**

1000 thermistors in a cardboard box.

**ELECTRICAL DATA**

Measurements made in still air at an ambient temperature of  $+23 \pm 1$  °C

Voltage range (r.m.s.) 100 to 265 V

Maximum inrush power at 110 V 200 W

Operating power at 110 V (r.m.s.), after 20 min 15 W  $\pm$  20%

Time to reach  $+130$  °C at 110 V max. 7 min

Temperature on standard test mounting  
after 20 min  
at 110 V (r.m.s.)  $+175 \pm 8$  °C

Dielectric withstanding voltage (r.m.s.)  
between terminals and an aluminium tube  
acting as outer electrode\* min. 4 kV

after  $48 \pm 0,5$  h at  $93 \pm 2\%$  R.H. and  
 $32 \pm 1$  °C, measured inside test chamber min. 4 kV

Insulation resistance between terminals  
and an aluminium tube acting as outer  
electrode at 500 V (d.c.) min. 10 M $\Omega$

after  $48 \pm 0,5$  h at  $93 \pm 2\%$  R.H. and  
 $32 \pm 1$  °C, measured inside test chamber min. 10 M $\Omega$

Operating temperature range at zero  
power and at maximum voltage  $-25$  to  $+60$  °C

\* The test voltage is a voltage increasing at a rate of 500 V/s, the maximum voltage is applied for 1 min.

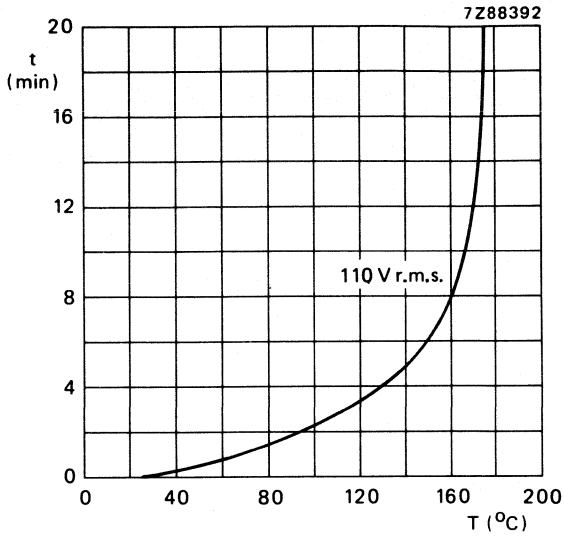

Fig. 2 Typical temperature versus time stabilization characteristic.  
Measured in standard test mounting.  
 $T_{amb} = +23\text{ }^{\circ}\text{C}$ .





## PTC CERAMIC HEATING ELEMENTS

### QUICK REFERENCE DATA

Type	2322 680 93009	2322 680 93011	
Maximum resistance at + 25 °C	2,5	3000	Ω
Switch temperature	200	200	°C
Maximum voltage	16 (d.c.)	265 (r.m.s.)	V
Maximum inrush current at max. voltage	16	1,4 to 5,4	A
Operating temperature range at zero power	-40 to + 125		°C
max. voltage	-25 to + 85		°C

### APPLICATION

Heating element for general use.

### DESCRIPTION

These thermistors have a positive temperature coefficient. They consist of a rectangular plate, with two aluminium contacts.

### MECHANICAL DATA

#### Outlines

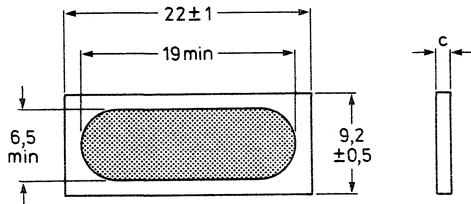

7285928

Fig. 1 Type 2322 680 93009, C = 1,0 + 0,15.  
Type 2322 680 93011, C = 1,6 + 0,5.

Marking	None
Mass	Type 2322 680 93009: 1,3 g approximately Type 2322 680 93011: 1,8 g approximately
Mounting	In any position by clamping
Impact	Free fall, 200 mm
Inflammability	Uninflammable

### PACKAGING

125 thermistors in a box.

**ELECTRICAL DATA**

Unless otherwise specified measured according to IEC 738-1 (1982).

Table 1

	catalogue number	
	2322 680 93009	2322 680 93011
Max. resistance at 25 °C	2,5 Ω ± 30%	3000 Ω
Temperature range for resistance value of 9 Ω	205 to 225 °C	
Resistance at 225 °C and 375 V (pulsed)		450 to 5000 Ω
Switch temperature	200 ± 8 °C	200 ± 8 °C
Max. voltage		
r.m.s.		265 V
d.c.	16 V	
Max. inrush current at V <sub>max</sub>	16 A	1,4 to 5,4 A
Max. steady state current at V <sub>max</sub>	250 mA	22 mA
Operating temperature range at zero power		-40 to + 125 °C
max. power		-25 to + 85 °C





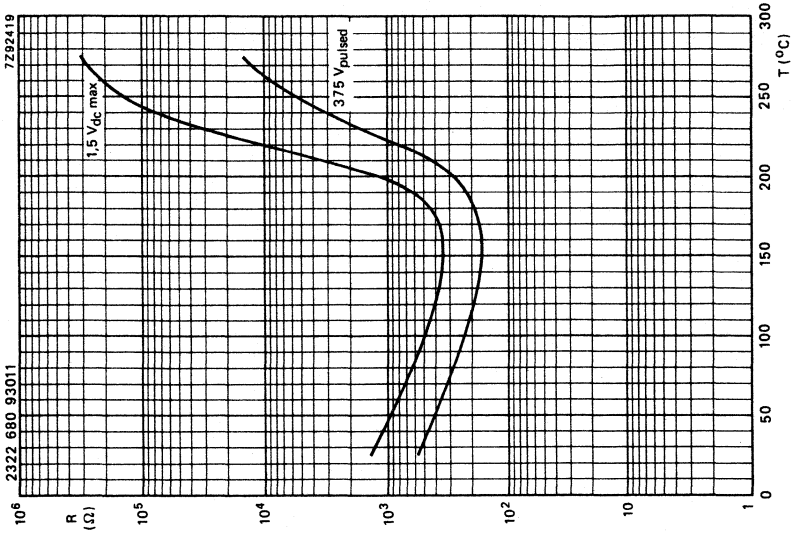

Fig. 3.

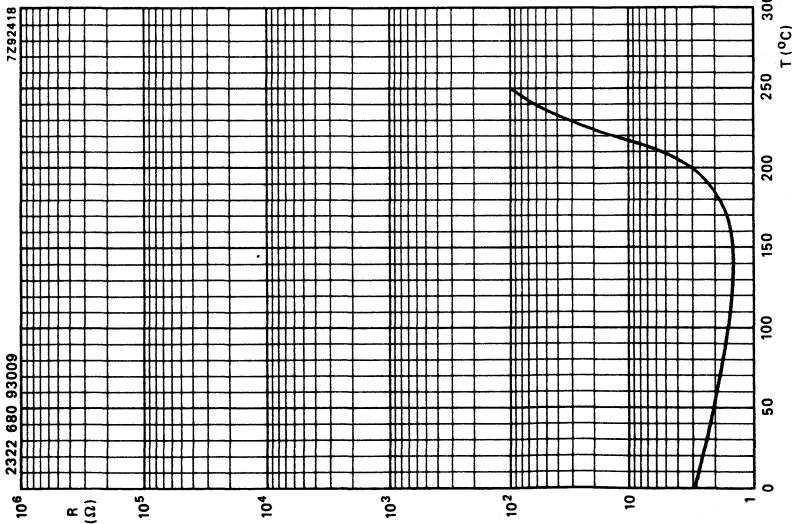

Fig. 2.

Typical resistance/temperature characteristics.





## DEVELOPMENT SAMPLE DATA

This information is derived from development samples made available for evaluation. It does not necessarily imply that the device will go into regular production.

2322 66. 1...1

## PTC THERMISTORS for overload protection

### QUICK REFERENCE DATA

Resistance at 25 °C	1,8 to 90 $\Omega$
Switch temperature	approx. 120 °C
Maximum d.c. voltage	56 V
Trip current at 10 °C	112 to 1360 mA
Operating temperature range at $V_{max}$	0 to +55 °C

### APPLICATION

Overload protection, for use in electric and electronic equipment.

### DESCRIPTION

These thermistors have a positive temperature coefficient. They consist of a disc with two tinned brass wires. The thermistor body is not lacquered.

### MECHANICAL DATA

Outlines

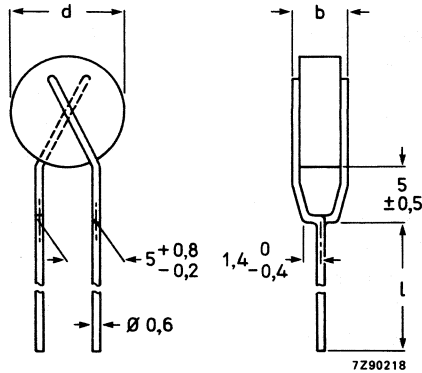

Fig. 1 For dimensions b, d and l see Table 1.

<b>Marking</b>	None
<b>Mass</b>	See Table 1
<b>Mounting</b>	In any position by soldering
<b>Robustness of terminations</b>	
Tensile strength	10 N
Bending	5 N
<b>Soldering</b>	
Solderability	max. 240 °C, max. 4 s
Resistance to heat	max. 265 °C, max. 11 s
<b>Impact</b>	200 mm free fall
<b>Inflammability</b>	Uninflammable

**Packaging**

Cardboard boxes containing following items for:

2322 660 1 . . . 1:	500
2322 661 1 . . . 1:	250
2322 662 11811:	200
2322 662 1 . . . 1:	100
2322 663 1 . . . 1:	100
2322 664 1 . . . 1:	100

**ELECTRICAL DATA**

Unless otherwise specified measured according to IEC publication 738-1 (1982).

Maximum current for not tripping at 55 °C

(measuring time 5 minutes)

 $I_{nt}$  See Table 1

Minimum current for tripping after 5 minutes at 10 °C

 $I_t = 2 I_{nt}$  See Table 1

Resistance at + 25 °C

 $R_{25}$  See Table 1

Switch temperature

 $T_s \approx 120$  °C

Maximum admissible current at 0 °C

 $I_{max}$  See Table 1

Maximum residual current at 56 V (d.c.) at 10 °C

 $I_{res max}$  See Table 1

Maximum d.c. voltage with a series resistor

56 V

Series resistor

 $R_s$  See Table 1

Maximum d.c. voltage without series resistor

18 V

Dissipation factor at  $T_s$ 

D See Table 1

Heat capacity

H See Table 1

Operating temperature range

at zero power

-25 to + 125 °C

at maximum voltage

0 to + 55 °C

Table 1

catalogue number	$I_{nt}$ at 55 °C mA	$I_t$ at 10 °C mA	$R_{25}$ approx. $\Omega$	$I_{max}$ at 0 °C mA	$I_{res max}$ at 10 °C mA	$R_s$ $\pm 5\%$ $\Omega$	D approx. mW/K	H approx. J/K	d mm	b max. mm	l $\pm 3$ mm	mass approx. g
2322 660 15691	56	112	90	460	30	56	6	0,08	4,5	4	20	0,35
2322 660 16891	68	136	60	600	30	51	6	0,08	4,5	4	20	0,35
2322 660 18291	82	164	42	750	30	43	6	0,08	4,5	4	20	0,35
2322 661 11011	100	200	32	950	35	36	7	0,15	6,5	4	20	0,47
2322 661 11211	120	240	22	1300	35	27	7	0,15	6,5	4	20	0,47
2322 661 11511	150	300	18	1600	40	22	7,5	0,16	8,0	4	20	0,65
2322 662 11811	180	360	12,5	2200	45	16	8	0,42	10,0	4,5	20	1,05
2322 662 12211	220	440	9	2900	50	13	9	0,55	12,0	4,5	20	1,43
2322 662 12711	270	540	6,5	4000	50	10	9	0,55	12,0	4,5	20	1,43
2322 663 13311	330	660	4,3	6300	60	5,6	10	0,83	13,0	5	20	2,15
2322 663 13911	390	780	3,8	7300	70	5,1	12	1,24	16,0	5	20	2,90
2322 663 14711	470	940	2,6	12000	70	2,7	12	1,24	16,0	5	20	2,90
2322 664 15611	560	1120	2,2	14000	100	2,4	16	2,34	20,0	6	16	5,30
2322 664 16811	680	1360	1,6	18000	100	2,0	16	2,34	20,0	6	16	5,30

DEVELOPMENT SAMPLE DATA



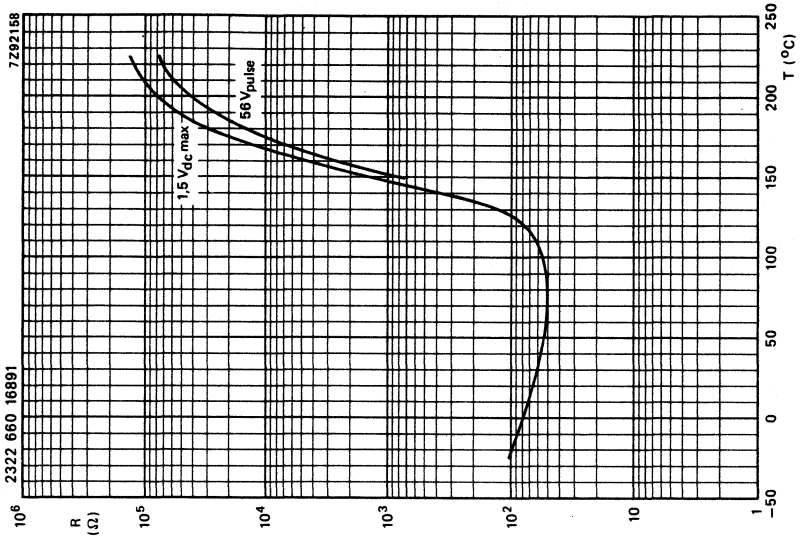

Fig. 3.

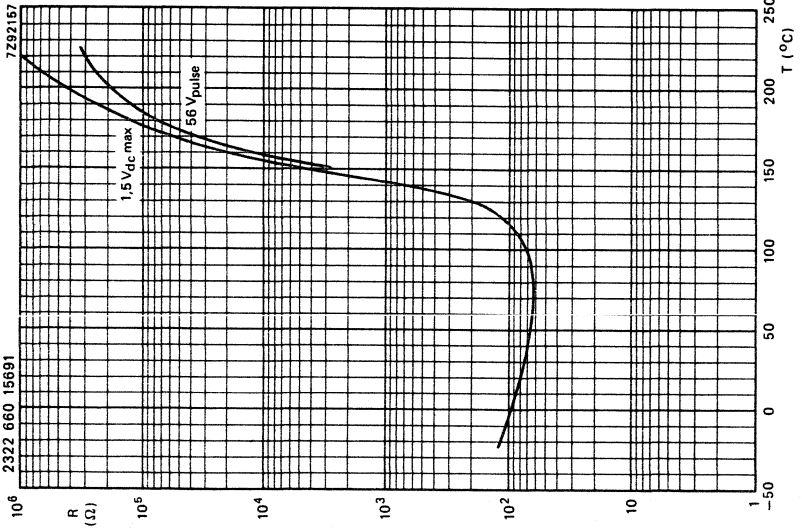

Fig. 2.

Typical resistance/temperature characteristics.



DEVELOPMENT SAMPLE DATA

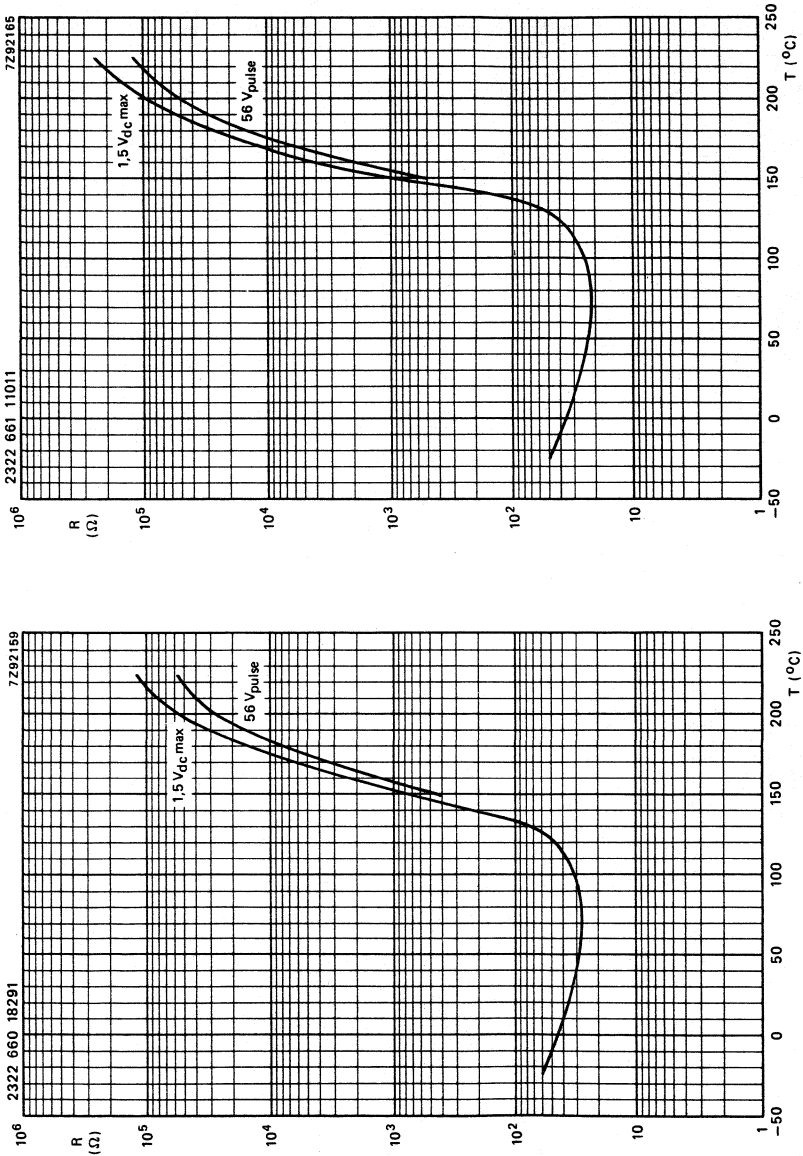

Fig. 4.

Fig. 5.

Typical resistance/temperature characteristics.



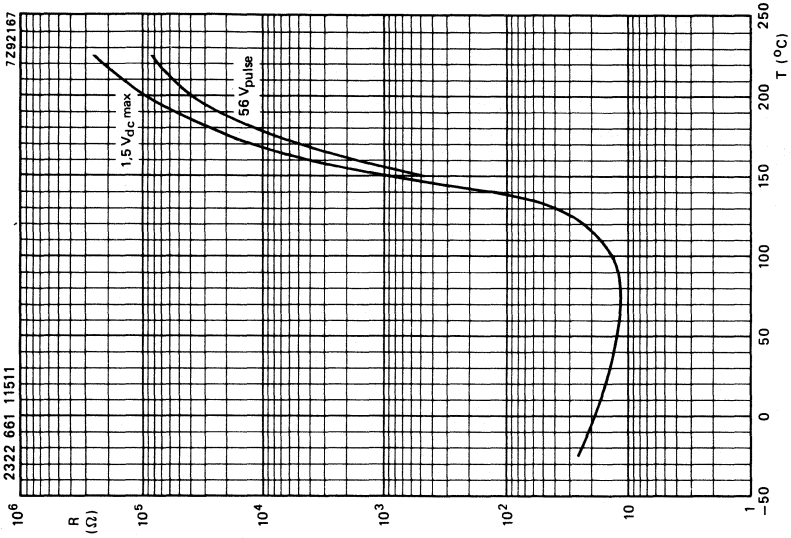

Fig. 7.

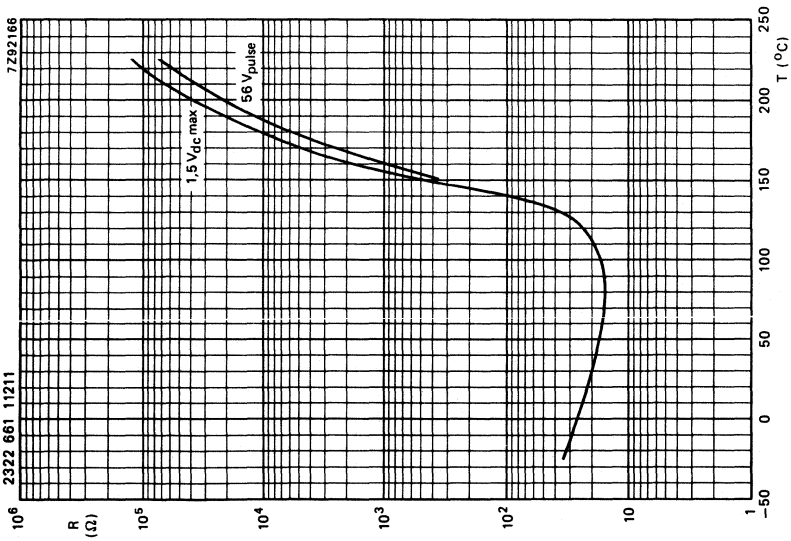

Fig. 6.

Typical resistance/temperature characteristics.





DEVELOPMENT SAMPLE DATA

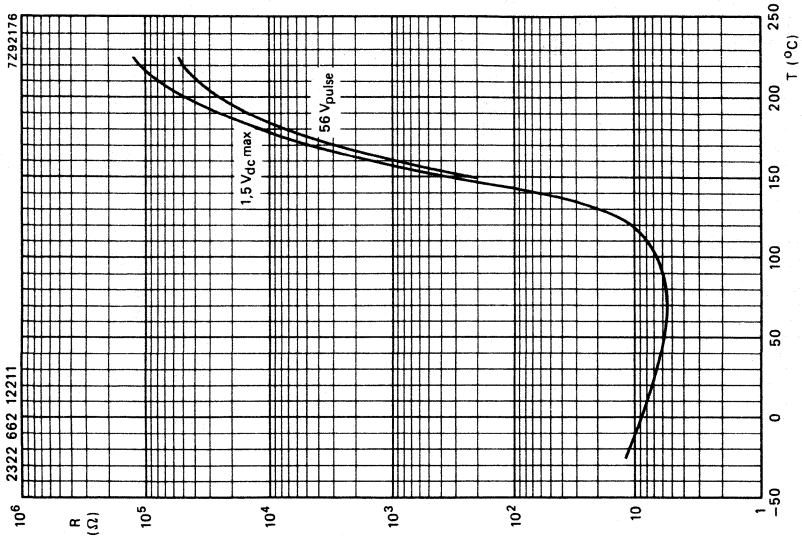

Fig. 9.

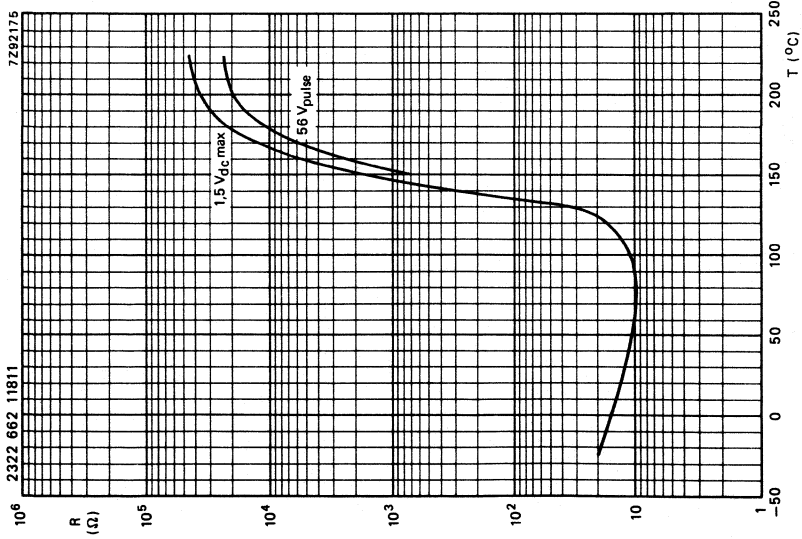

Fig. 8.

Typical resistance/temperature characteristics.



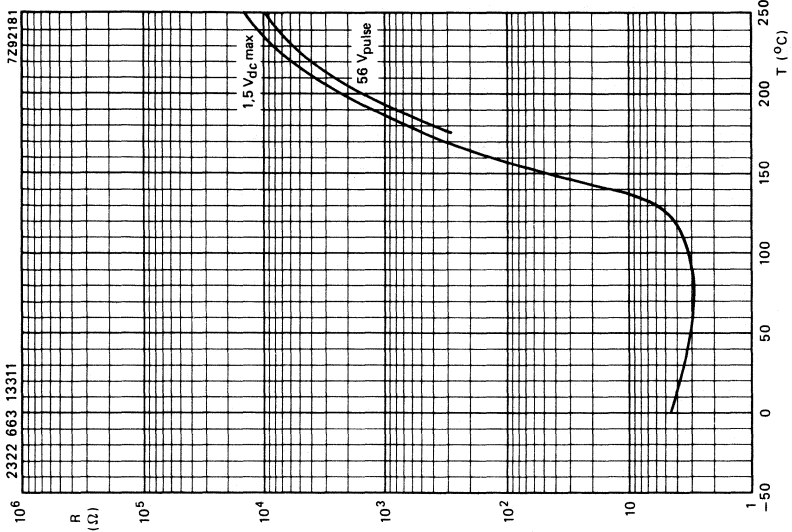

Fig. 11.

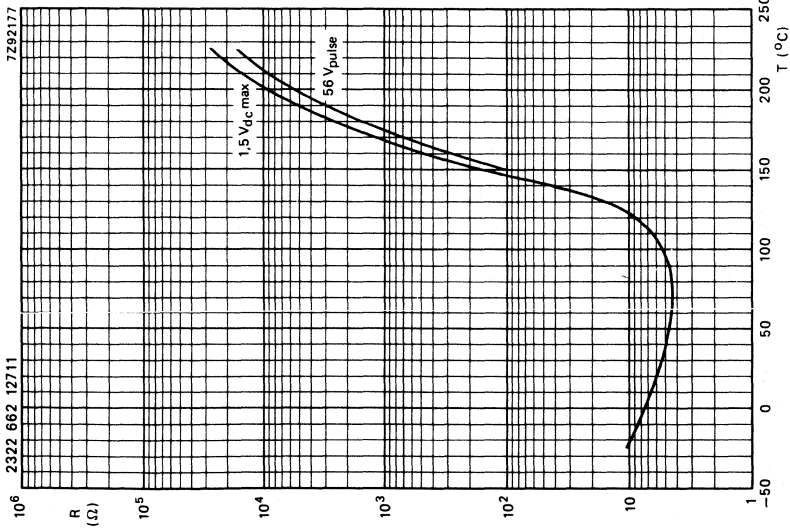

Fig. 10.

Typical resistance/temperature characteristics.

DEVELOPMENT SAMPLE DATA

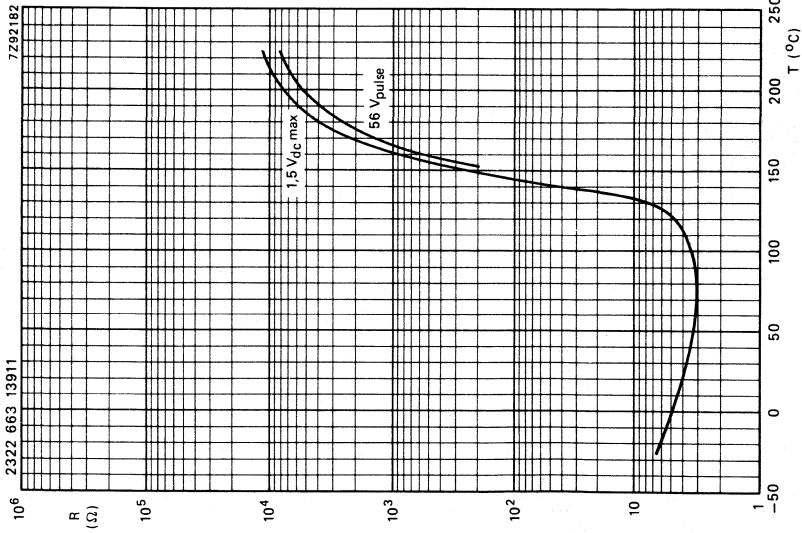

Fig. 12.

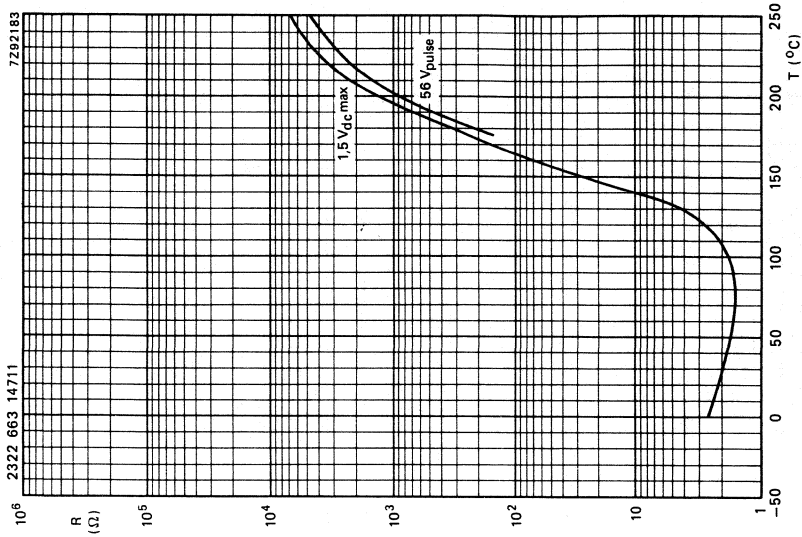

Fig. 13.

Typical resistance/temperature characteristics.



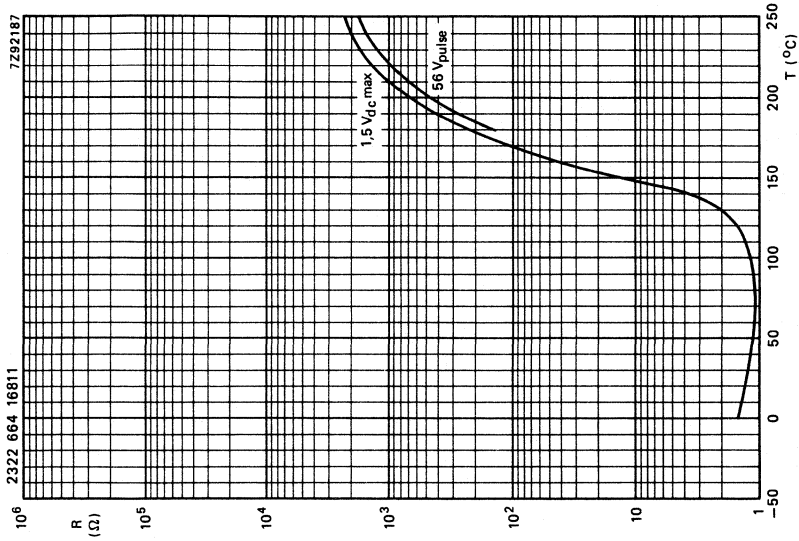

Fig. 15.

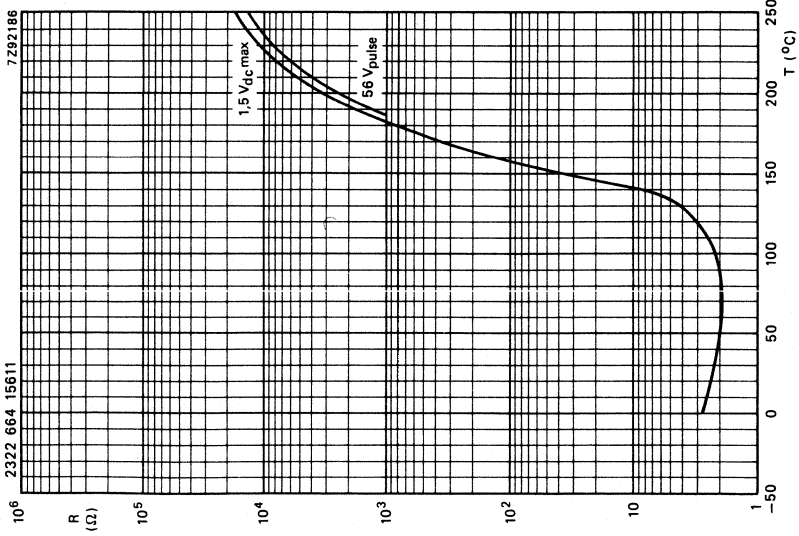

Fig. 14.

Typical resistance/temperature characteristics.



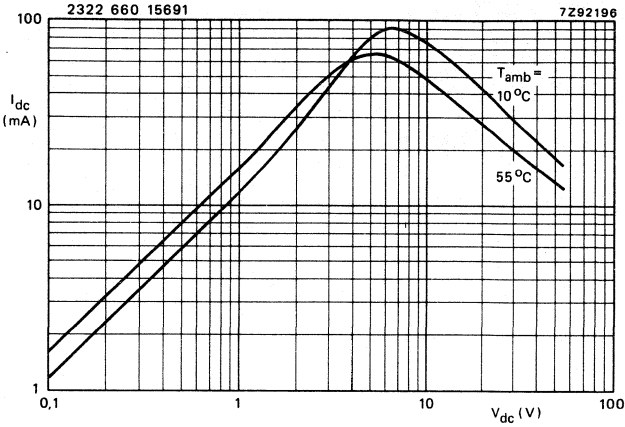

Fig. 16.

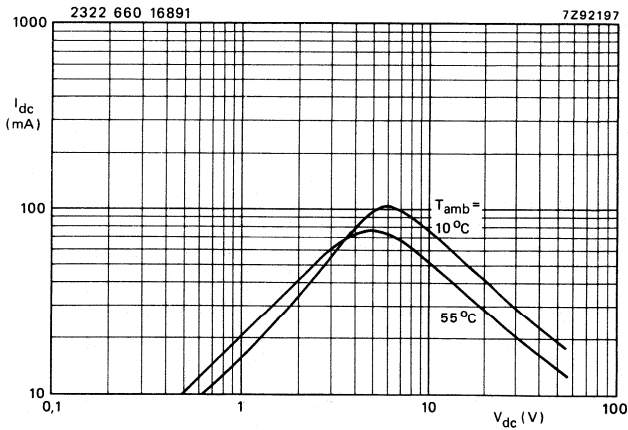

Fig. 17.

Typical voltage/current characteristics.

DEVELOPMENT SAMPLE DATA



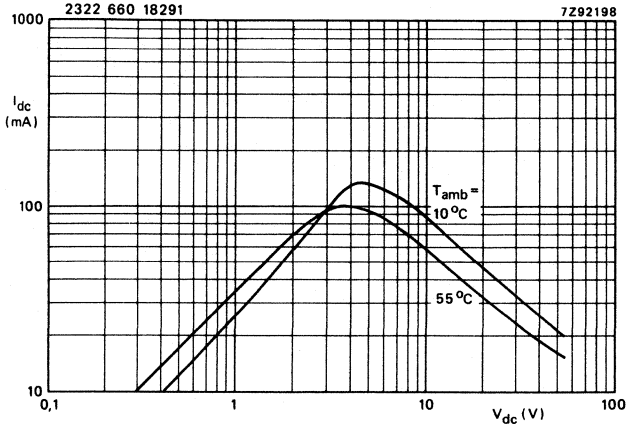

Fig. 18.

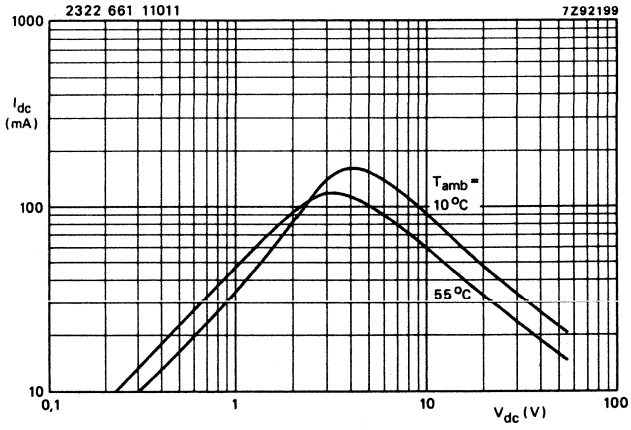

Fig. 19.

Typical voltage/current characteristics.



DEVELOPMENT SAMPLE DATA

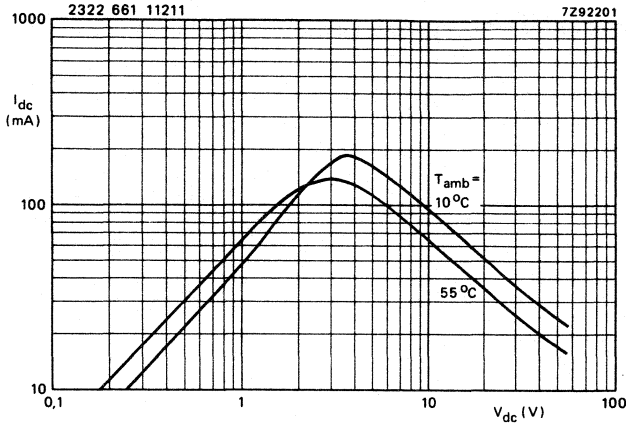

Fig. 20.

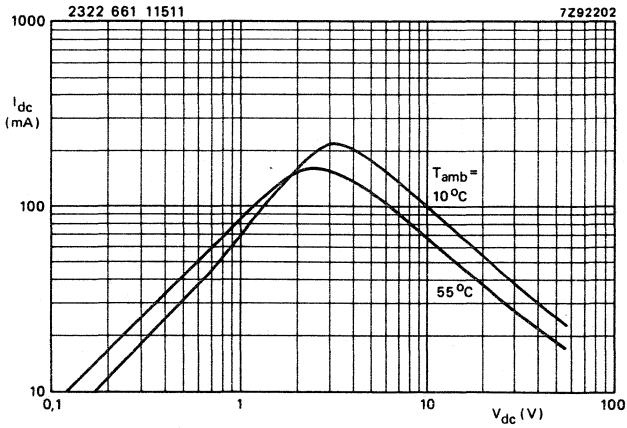

Fig. 21.

Typical voltage/current characteristics.



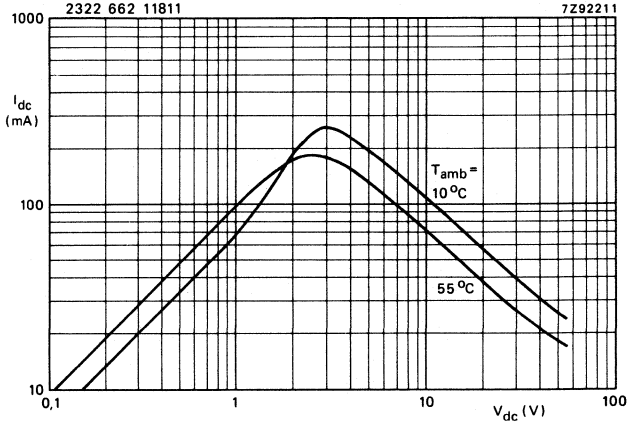

Fig. 22.

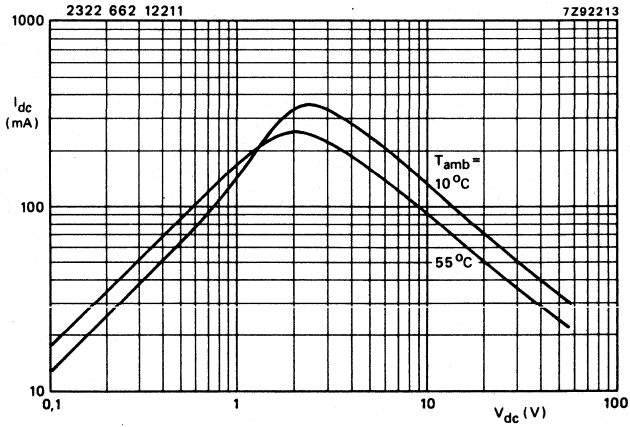

Fig. 23.

Typical voltage/current characteristics.



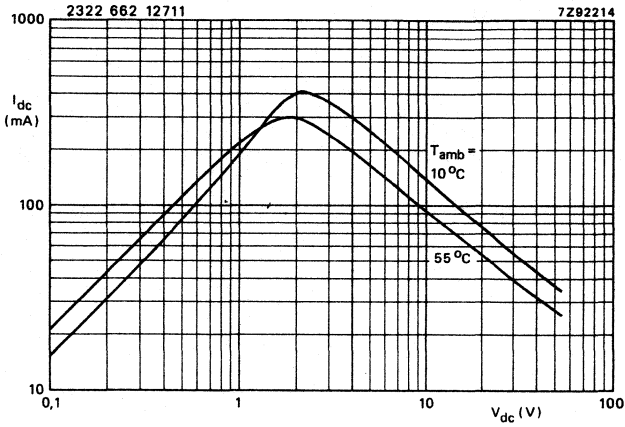

Fig. 24.

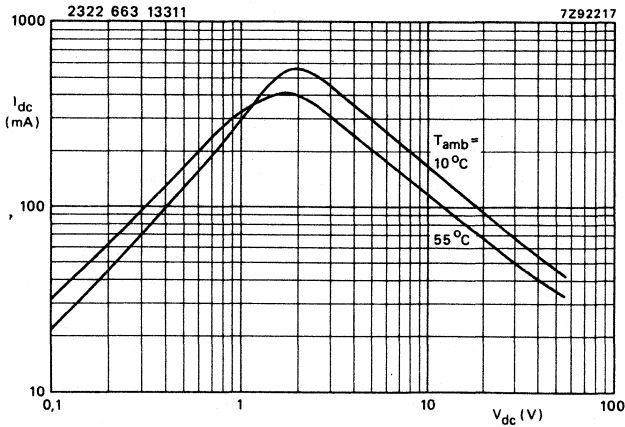

Fig. 25.

Typical voltage/current characteristics.



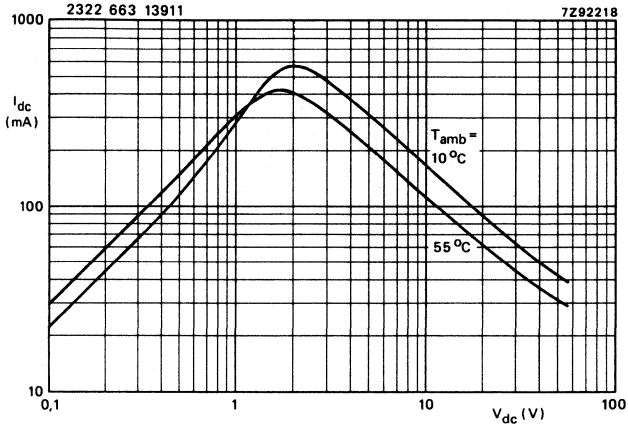

Fig. 26.

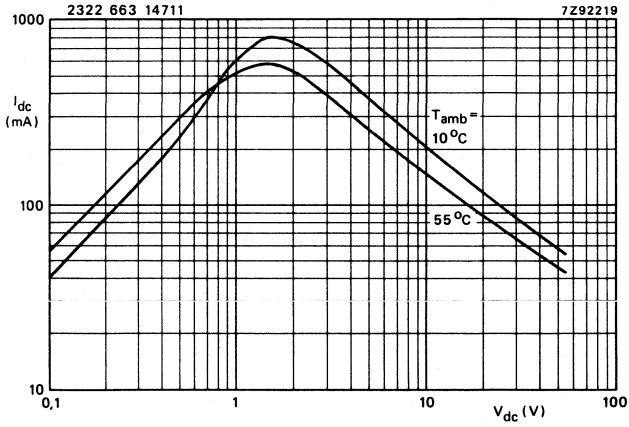

Fig. 27.

Typical voltage/current characteristics.

DEVELOPMENT SAMPLE DATA

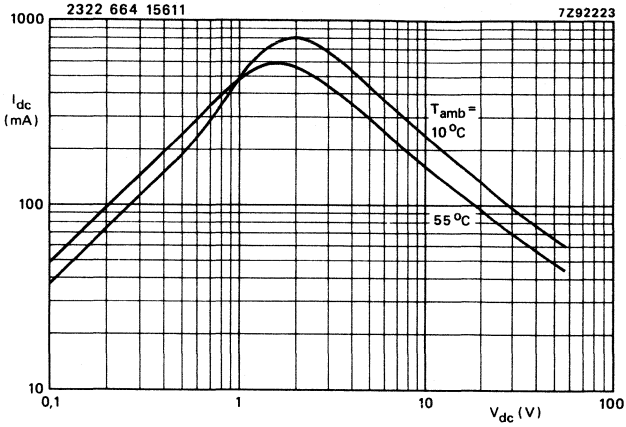

Fig. 28.

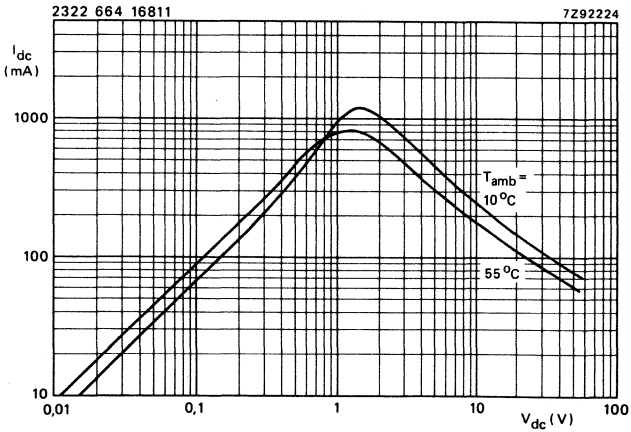

Fig. 29.

Typical voltage/current characteristics.





## DEVELOPMENT SAMPLE DATA

This information is derived from development samples made available for evaluation. It does not necessarily imply that the device will go into regular production.

2322 66. 1...3

## PTC THERMISTORS

for overload protection

### QUICK REFERENCE DATA

Resistance at 25 °C	3,5 to 1900 $\Omega$
Switch temperature	approx. 120 °C
Maximum r.m.s. voltage	265 V
Trip current at 10 °C	24 to 940 mA
Operating temperature range at $V_{max}$	0 to +55 °C

### APPLICATION

Overload protection; for use in electrical and electronic equipment.

### DESCRIPTION

These thermistors have a positive temperature coefficient. They consist of a disc with two tinned brass wires. The thermistor body is not lacquered.

### MECHANICAL DATA

Outlines

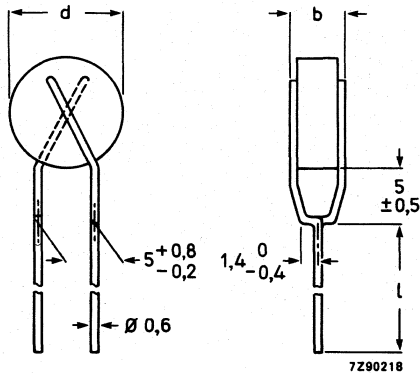

Fig. 1 For dimensions b, d and l see Table 1.

<b>Marking</b>	None
<b>Mass</b>	See Table 1
<b>Mounting</b>	in any position by soldering
<b>Robustness of terminations</b>	
Tensile strength	10 N
Bending	5 N
<b>Soldering</b>	
Solderability	max. 240 °C, max. 4 s
Resistance to heat	max. 265 °C, max. 11 s
<b>Impact</b>	200 mm free fall
<b>Inflammability</b>	Uninflammable

**Packaging**

Cardboard boxes containing following items for:

2322 660 1... 3:	500
2322 661 1... 3:	250
2322 662 11213:	200
2322 662 1... 3:	100
2322 663 1... 3:	100
2322 664 1... 3:	100

**ELECTRICAL DATA**

Unless otherwise specified measured according to IEC publication 738-1 (1982)

Maximum current for not tripping at 55 °C  
(measuring time 5 minutes) $I_{nt}$  See Table 1

Minimum current for tripping after 5 minutes at 10 °C

 $I_t = 2I_{nt}$  See Table 1

Resistance at + 25 °C

 $R_{25}$  See Table 1

Switch temperature

 $T_s \approx 120$  °C

Maximum admissible current at 0 °C

 $I_{max}$  See Table 1

Maximum residual current at 265 V (r.m.s.) at 10 °C

 $I_{res max}$  See Table 1

Maximum r.m.s. voltage with a series resistor

265 V

Series resistor

 $R_s$  See Table 1Dissipation factor at  $T_s$ 

D See Table 1

Heat capacity

H See Table 1

Operating temperature range

at zero power

-25 to + 125 °C

at minimum voltage

0 to + 55 °C

Table 1

catalogue number	$I_{nt}$ at 55 °C mA	$I_t$ at 10 °C mA	$R_{25}$ approx. Ω	$I_{max}$ at 0 °C mA	$I_{res max}$ at 10 °C mA	$R_s$ ± 5% Ω	D approx. mW/K	H approx. J/K	d mm	b max. mm	l ± 3 mm	mass approx. g
2322 660 11293	12	24	1900	110	5	1100	6	0,12	4,5	5	20	0,45
2322 660 11593	15	30	1200	135	5	1100	6	0,12	4,5	5	20	0,45
2322 660 11893	18	36	850	165	5	1000	6	0,12	4,5	5	20	0,45
2322 660 12293	22	44	560	200	6	910	6	0,12	4,5	5	20	0,45
2322 660 12793	27	54	380	250	6	820	6	0,12	4,5	5	20	0,45
2322 661 13393	33	66	280	290	7	750	7	0,22	6,5	5	20	0,70
2322 661 13993	39	78	200	350	7	620	7	0,22	6,5	5	20	0,70
2322 661 14793	47	94	140	420	7	560	7	0,22	6,5	5	20	0,70
2322 661 15693	56	112	100	500	8	470	7	0,22	6,5	5	20	0,70
2322 661 16893	68	136	72	600	8	390	8	0,33	8,0	5	20	0,90
2322 661 18293	82	164	50	730	9	330	8	0,33	8,0	5	20	0,90
2322 661 11013	100	200	33	900	9	270	8	0,33	8,0	5	20	0,90
2322 662 11213	120	240	26	1100	12	220	8,5	0,48	10,0	5	20	1,30
2322 662 11513	150	300	20	1300	12	200	9,5	0,68	12,0	5	20	1,80
2322 662 11813	180	360	14	1700	14	150	9,5	0,68	12,0	5	20	1,80
2322 663 12213	220	440	10	2100	16	120	10	0,85	13,0	5	20	2,15
2322 663 12713	270	540	8	2500	19	100	12	1,30	16,0	5	20	2,90
2322 664 13313	330	660	7	3000	25	82	16	2,40	20,0	6	16	5,30
2322 664 13913	390	780	5	3600	25	68	16	2,40	20,0	6	16	5,30
2322 664 14713	470	940	3,5	4300	25	56	16	2,40	20,0	6	16	5,30

DEVELOPMENT SAMPLE DATA



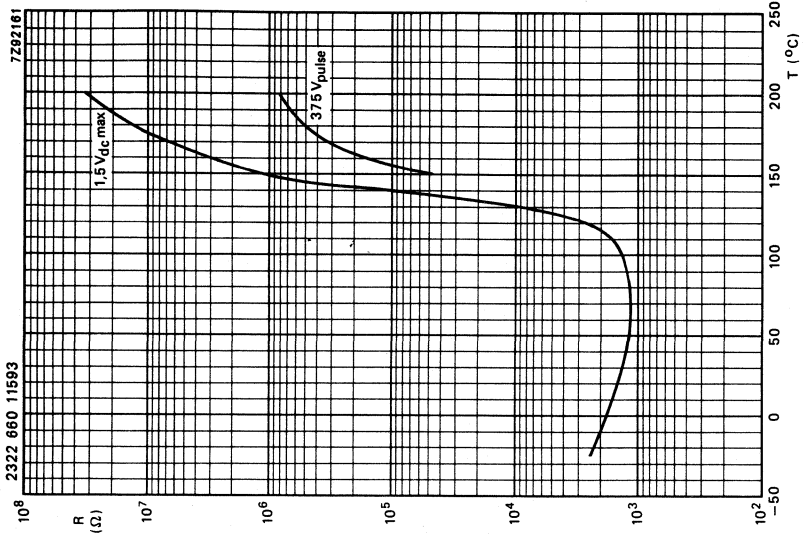

Fig. 3.

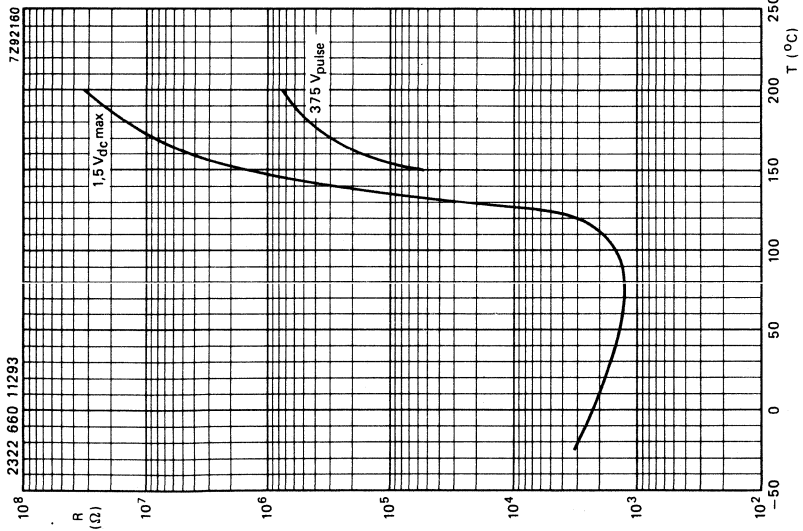

Fig. 2.

Typical resistance/temperature characteristics.





DEVELOPMENT SAMPLE DATA

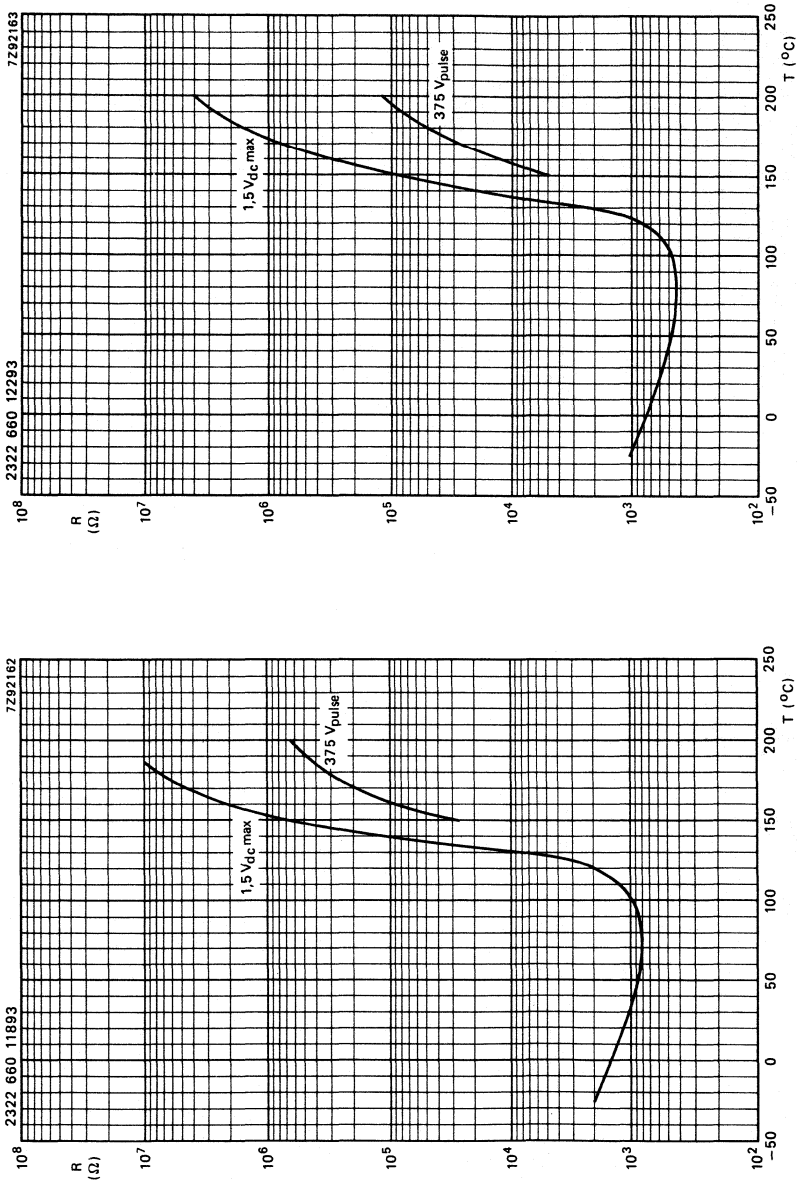

Fig. 5.

Fig. 4.

Typical resistance/temperature characteristics.



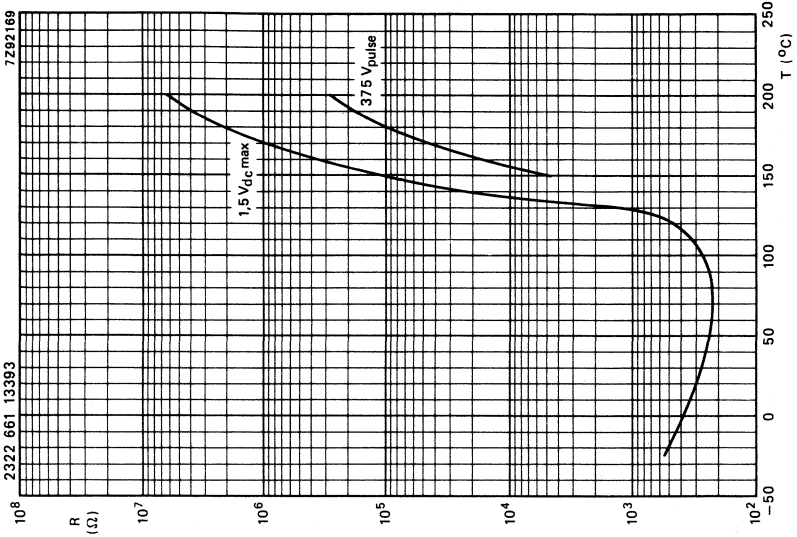

Fig. 7.

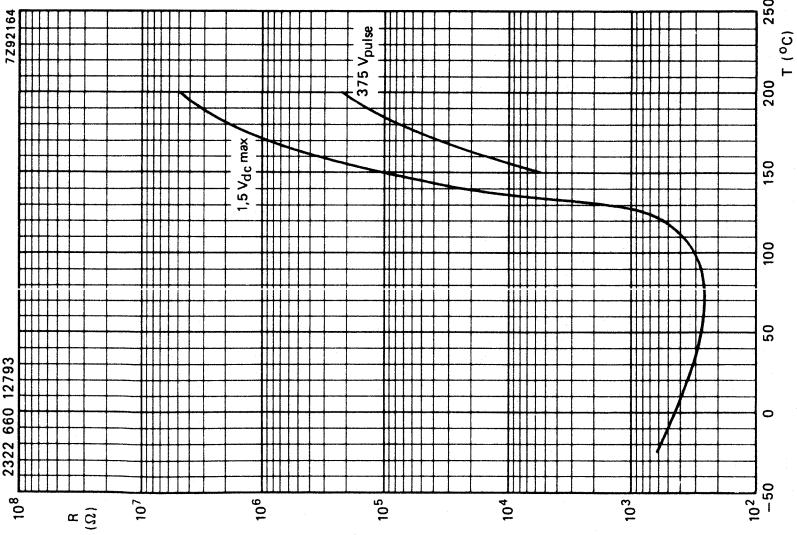

Fig. 6.

Typical resistance/temperature characteristics.



DEVELOPMENT SAMPLE DATA

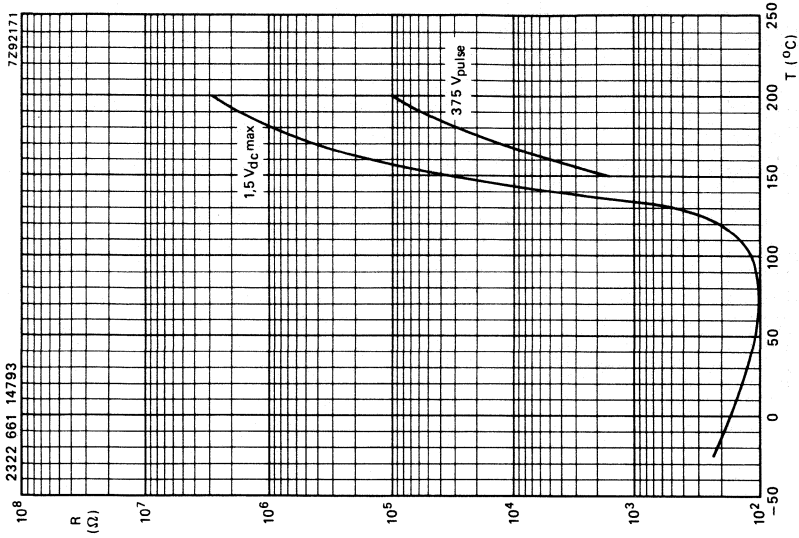

Fig. 9.

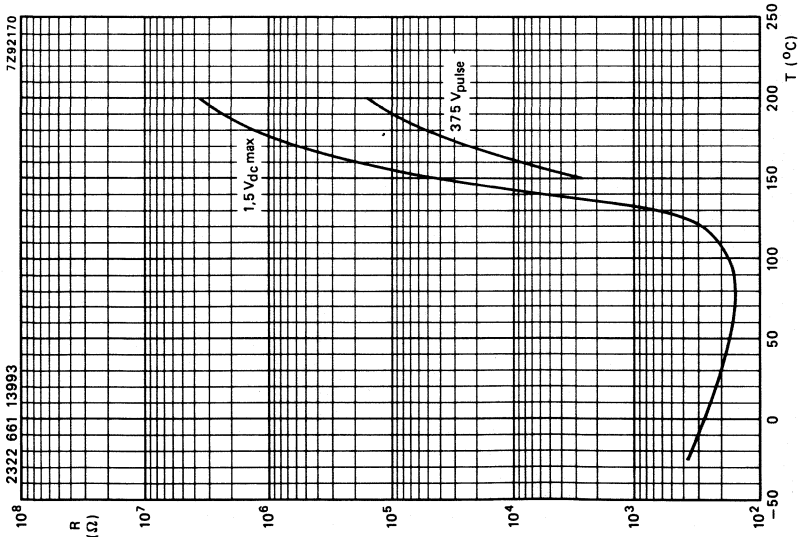

Fig. 8.

Typical resistance/temperature characteristics.



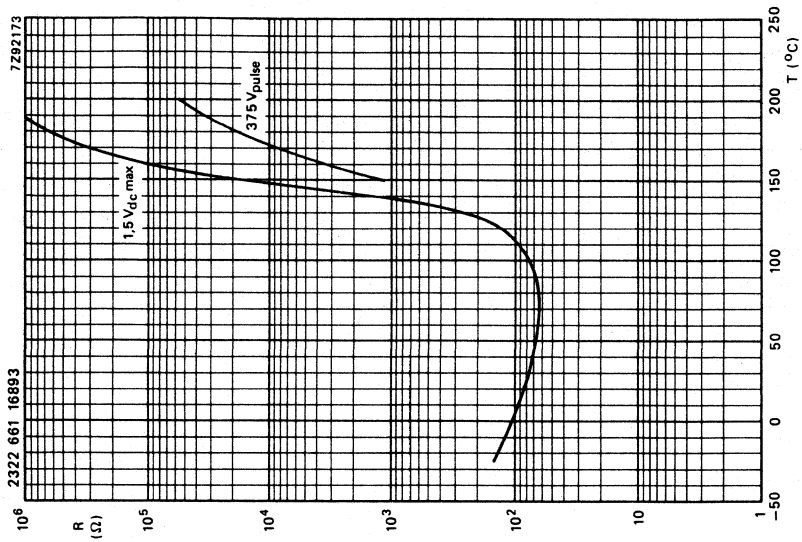

Fig. 11.

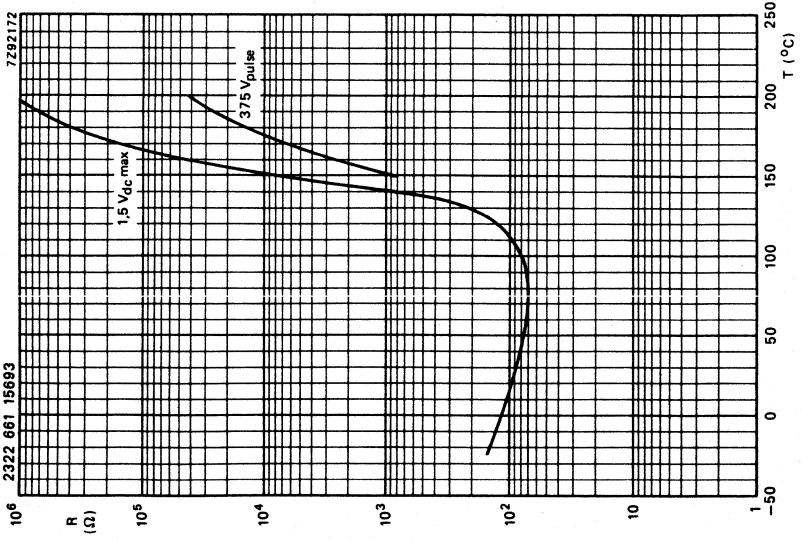

Fig. 10.

Typical resistance/temperature characteristics.



DEVELOPMENT SAMPLE DATA

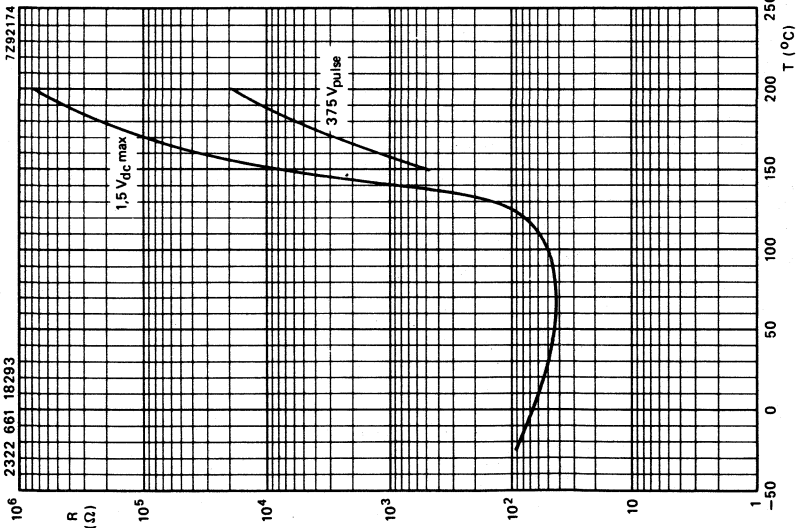
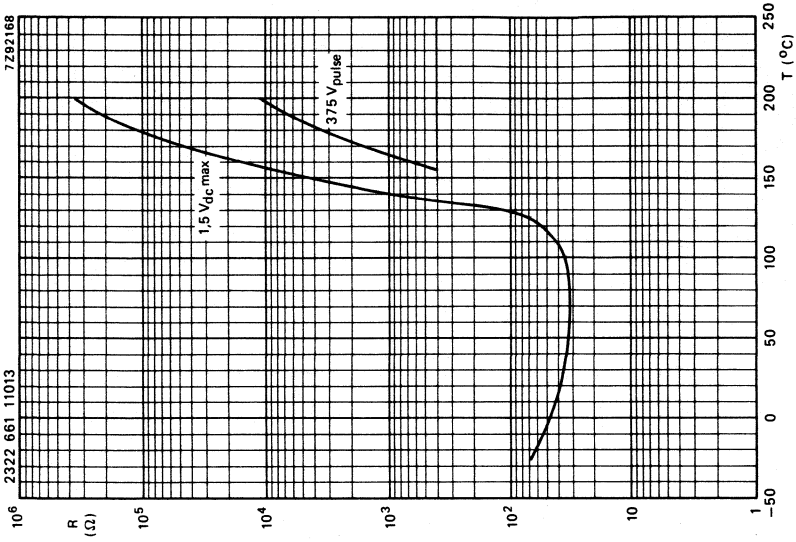

Fig. 13.

Fig. 12.

Typical resistance/temperature characteristics.



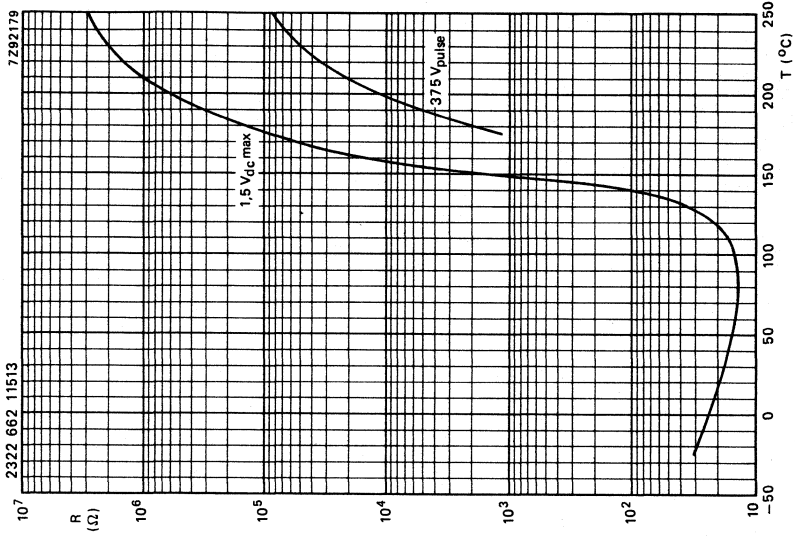

Fig. 15.

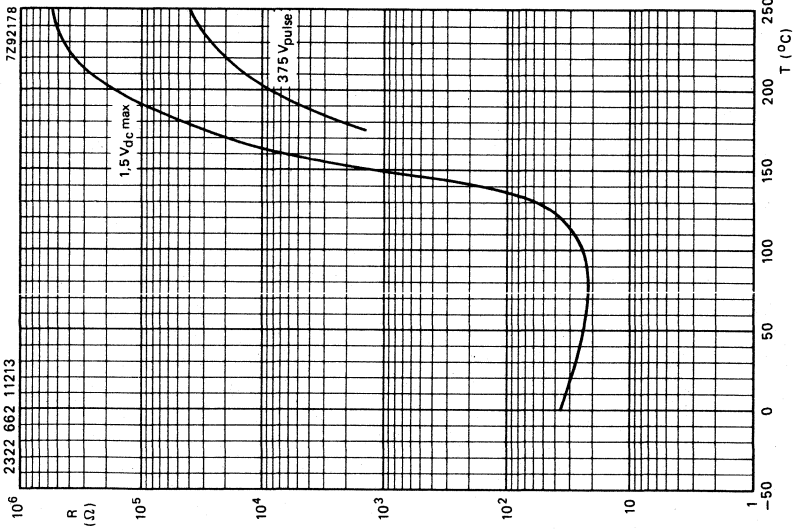

Fig. 14.

Typical resistance/temperature characteristics.

DEVELOPMENT SAMPLE DATA

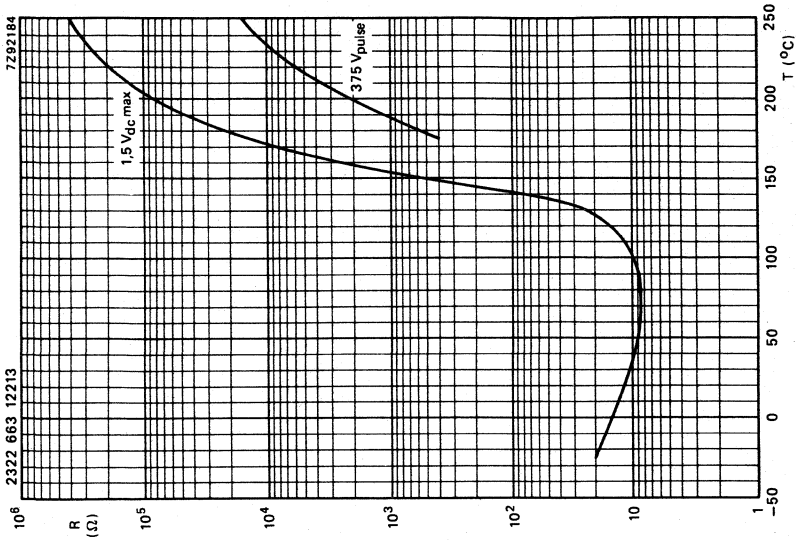

Fig. 17.

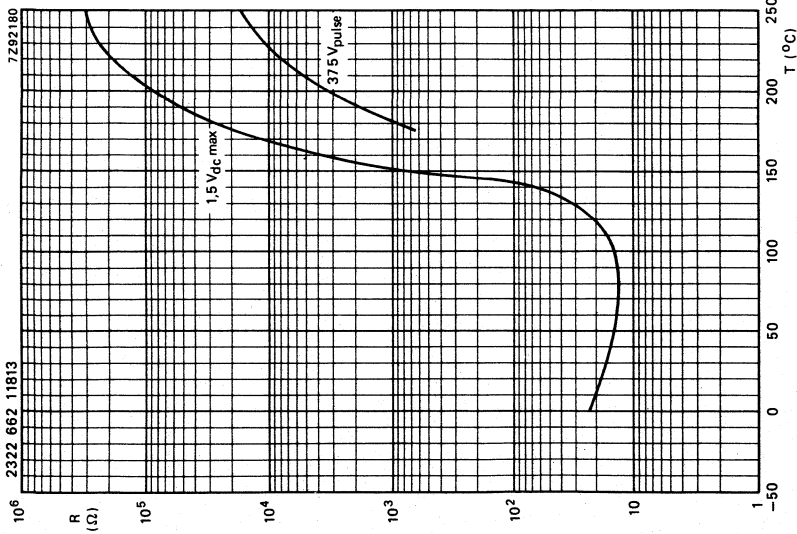

Fig. 16.

Typical resistance/temperature characteristics.



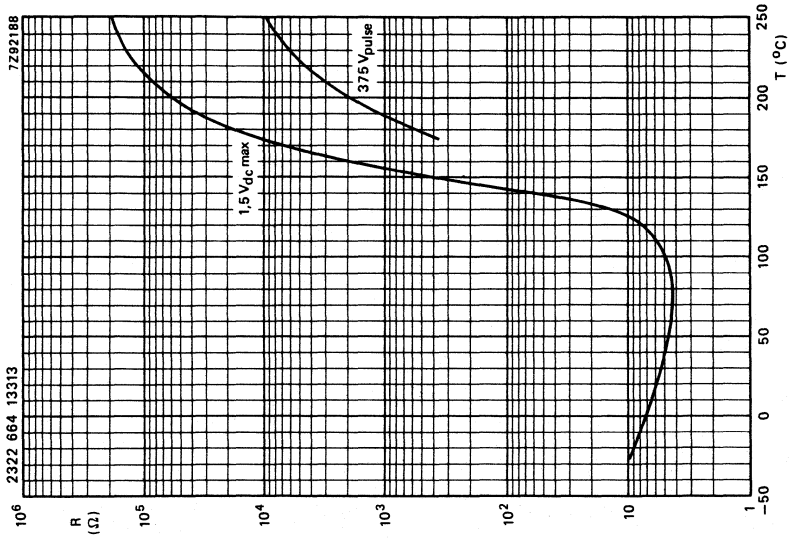

Fig. 19.

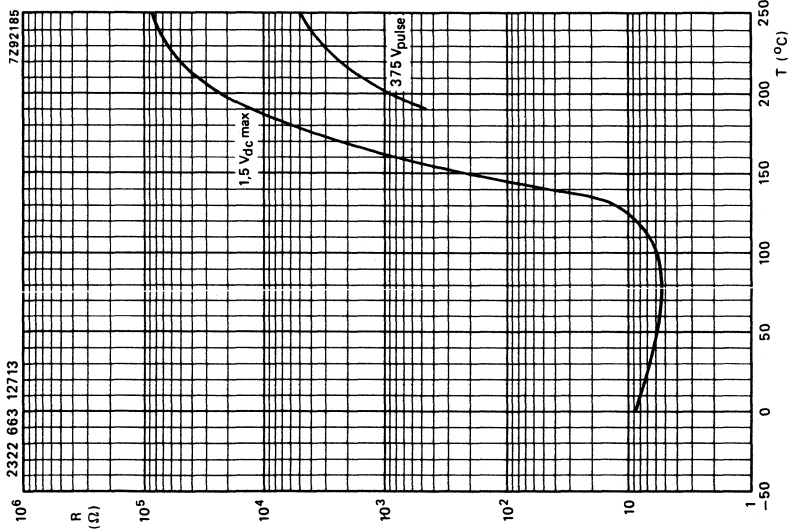

Fig. 18.

Typical resistance/temperature characteristics.





DEVELOPMENT SAMPLE DATA

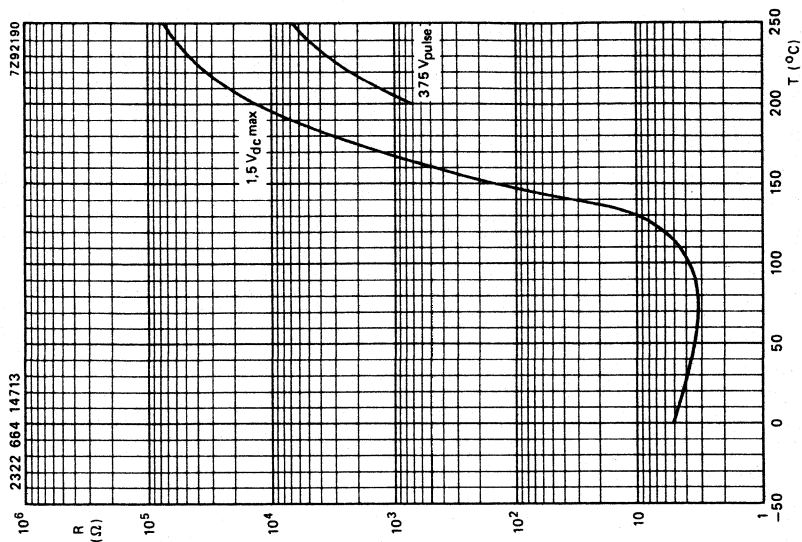

Fig. 21.

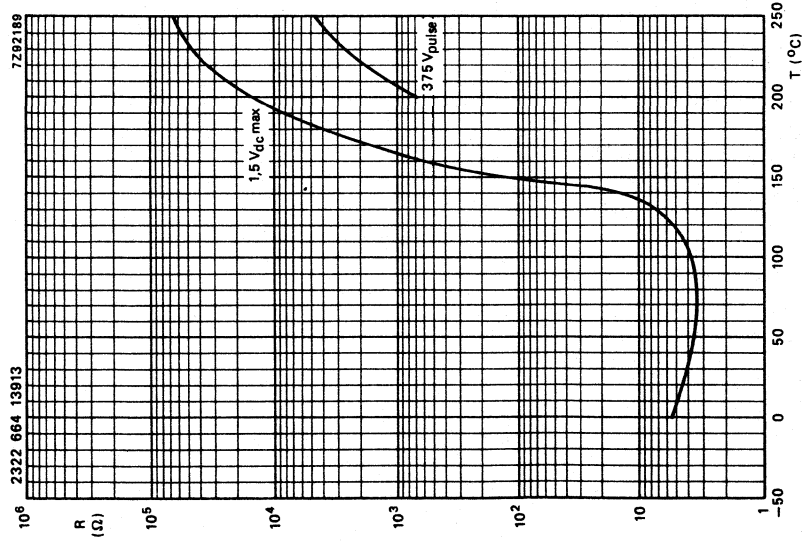

Fig. 20.

Typical resistance/temperature characteristics.



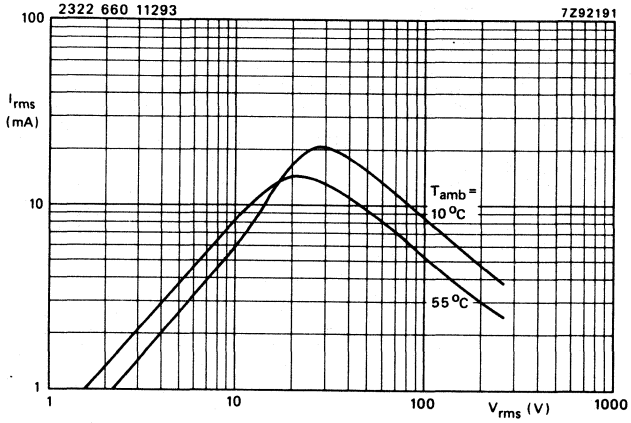

Fig. 22.

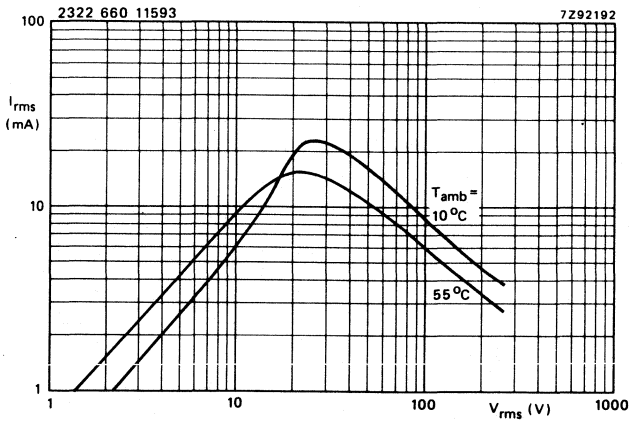

Fig. 23.

Typical voltage/current characteristics.

DEVELOPMENT SAMPLE DATA

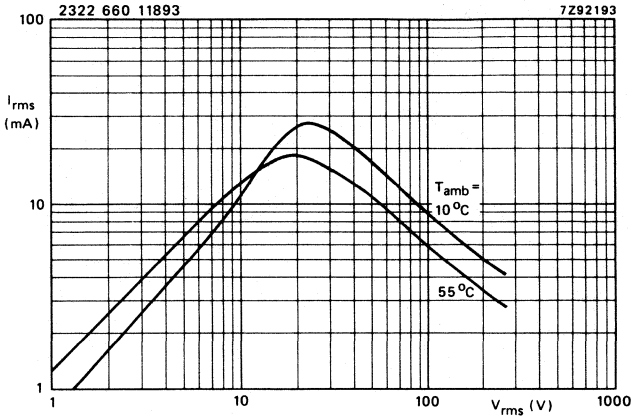

Fig. 24.

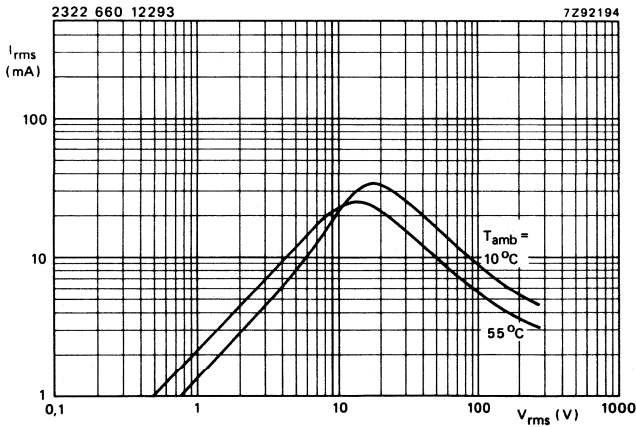

Fig. 25.

Typical voltage/current characteristics.

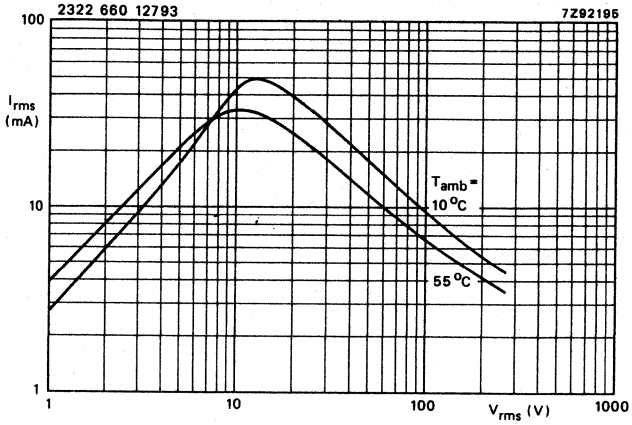

Fig. 26.

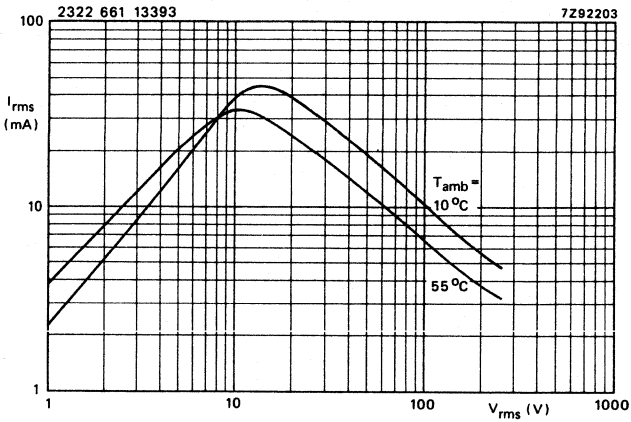

Fig. 27.

Typical voltage/current characteristics.

DEVELOPMENT SAMPLE DATA

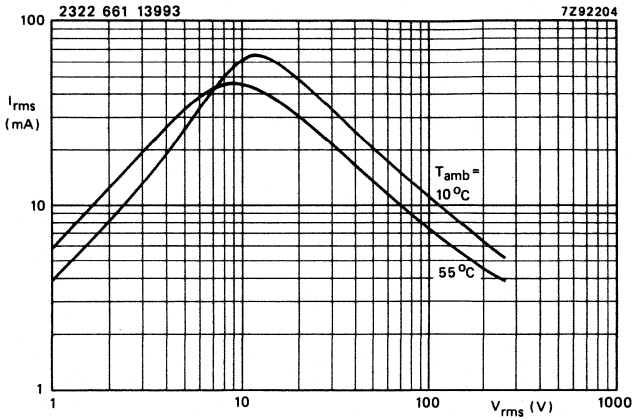

Fig. 28.

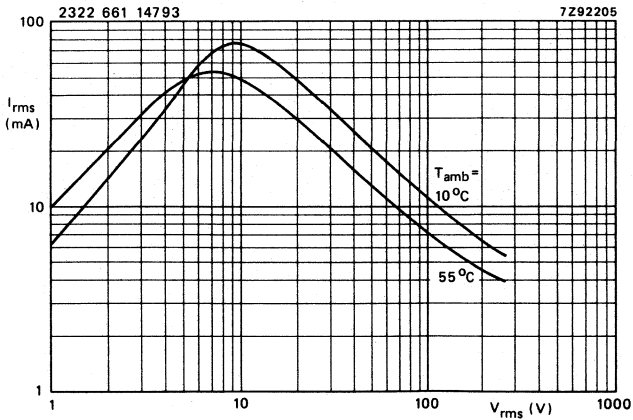

Fig. 29.

Typical voltage/current characteristics.

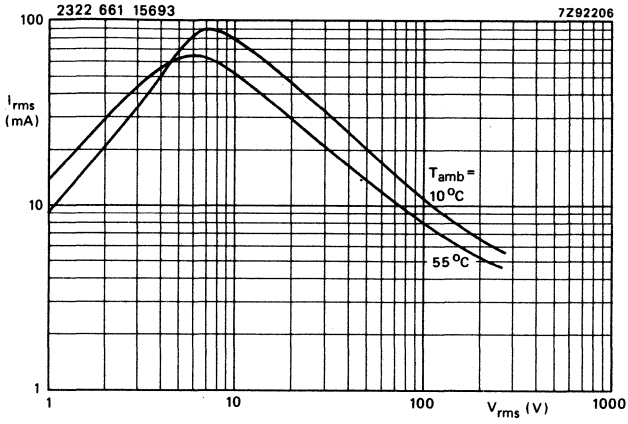

Fig. 30.

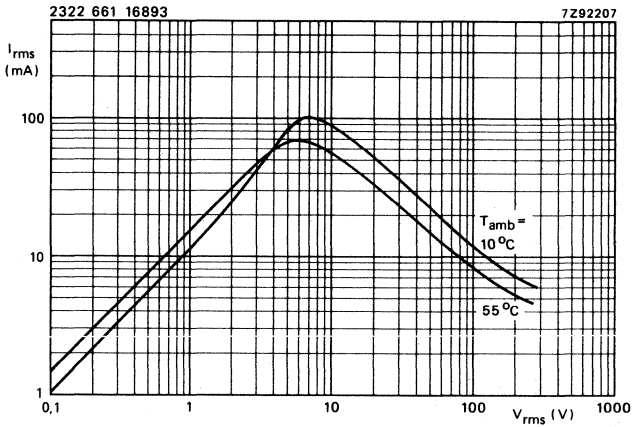

Fig. 31.

Typical voltage/current characteristics.

DEVELOPMENT SAMPLE DATA

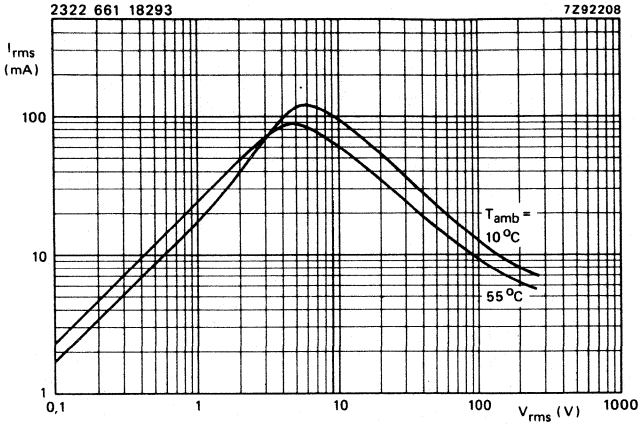

Fig. 32.

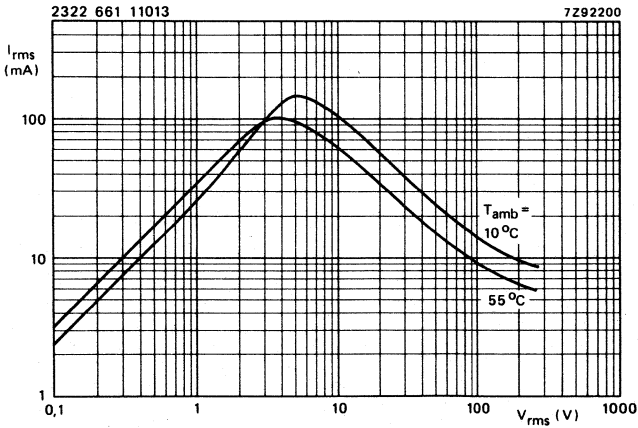

Fig. 33.

Typical voltage/current characteristics.

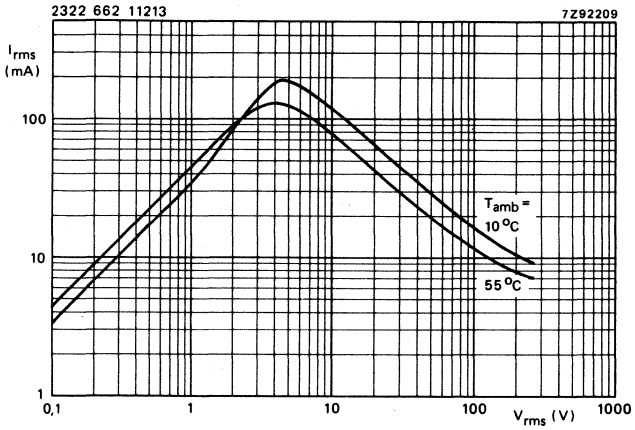

Fig. 34.

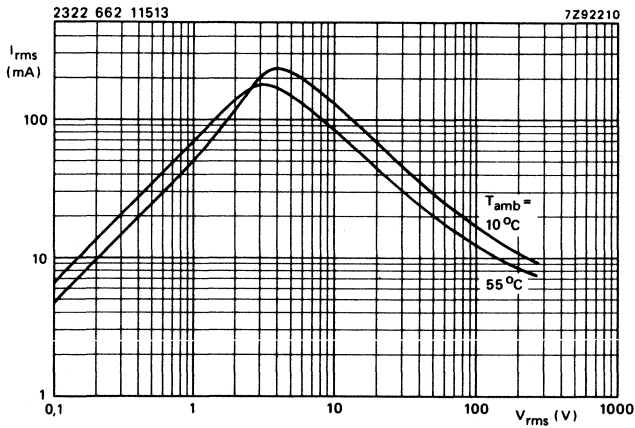

Fig. 35.

Typical voltage/current characteristics.



DEVELOPMENT SAMPLE DATA

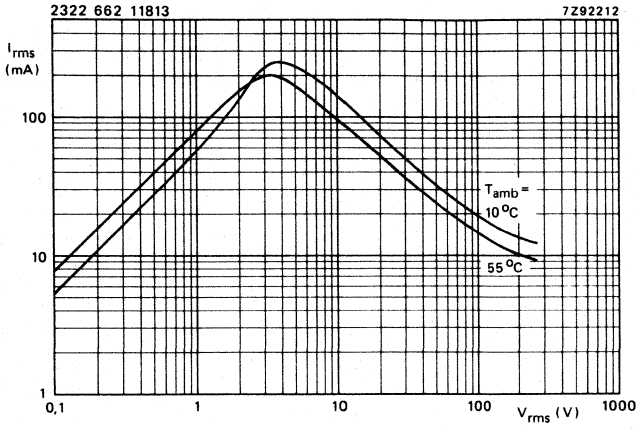

Fig. 36.

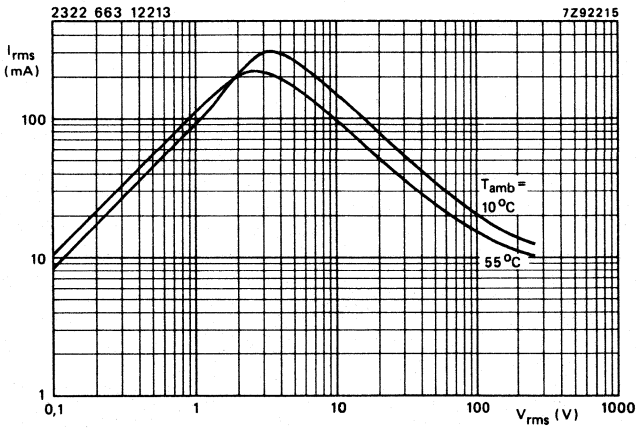

Fig. 37.

Typical voltage/current characteristics.

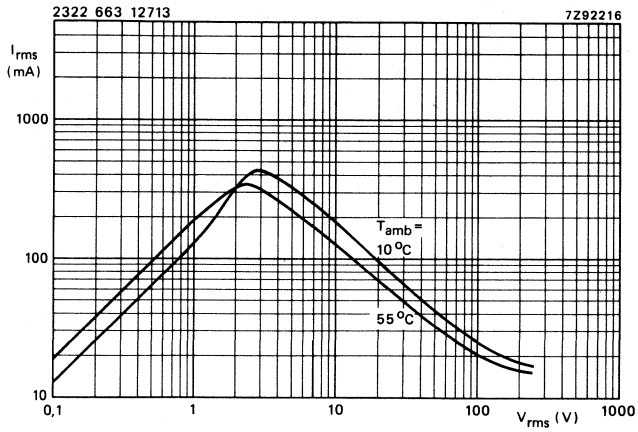

Fig. 38.

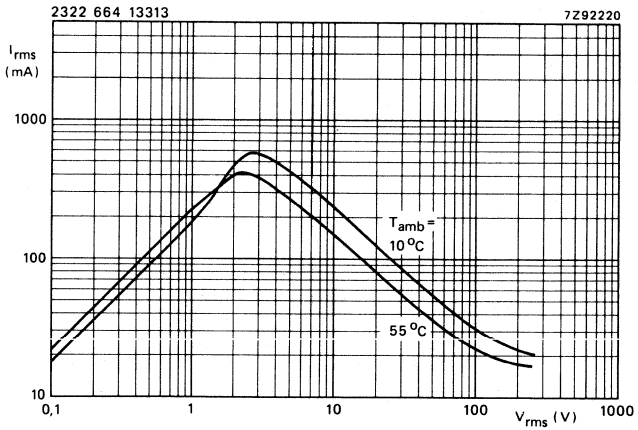

Fig. 39.

Typical voltage/current characteristics.

DEVELOPMENT SAMPLE DATA

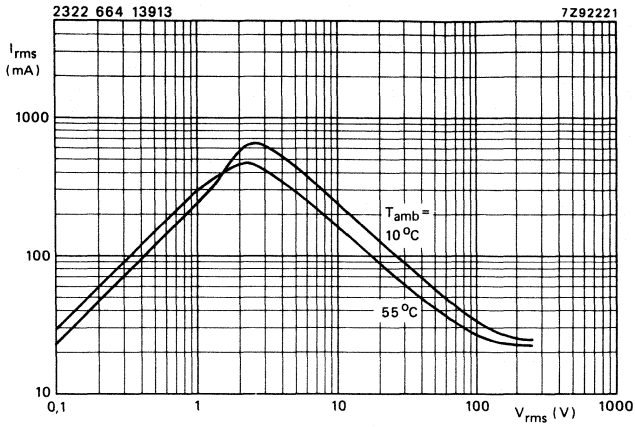

Fig. 40.

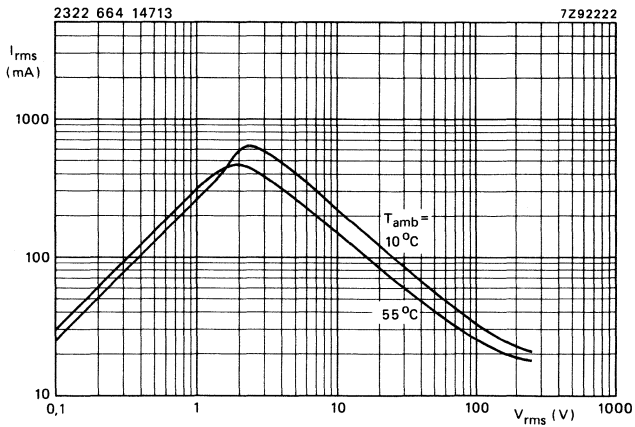

Fig. 41.

Typical voltage/current characteristics.





## PTC THERMISTORS

for overload protection

### QUICK REFERENCE DATA

Resistance at $T_{amb} = +25\text{ }^{\circ}\text{C}$	see Tables 2 and 3
Maximum resistance at $T_{amb} = +115\text{ }^{\circ}\text{C}$	see Tables 2 and 3
Switch temperature	+115 $^{\circ}\text{C}$
Maximum voltage (d.c. or r.m.s.)	60 V (Table 2) or 245 V (Table 3)
Dissipation factor	see Tables 2 and 3
Ambient temperature range at maximum voltage	0 to +55 $^{\circ}\text{C}$

### APPLICATION

For protection of electric and electronic components against overload, e.g. motors, transformers, light dimmers, etc.

A selection from our range of PTC thermistors which are suitable for this purpose is given.

### DESCRIPTION

These thermistors have a positive temperature coefficient. They consist of a disc with two tinned copper or brass wires. The thermistors are neither lacquered nor insulated.

### MECHANICAL DATA

Outlines	see Figs 1 and 2
Marking	none
Mass	see Table 1
Mounting	in any position by soldering
<b>Robustness of terminations</b>	
Tensile strength	
Thermistors of Fig. 1	20 N
Thermistors of Fig. 2	10 N
Bending	
Thermistors of Fig. 1	10 N
Thermistors of Fig. 2	5 N
<b>Soldering</b>	
Solderability	max. 240 $^{\circ}\text{C}$ , max. 4 s
Resistance to heat	max. 260 $^{\circ}\text{C}$ , max. 11 s
<b>Impact</b>	
Free fall	1 m
<b>Inflammability</b>	unflammable



Table 1 Outlines

Dimensions in mm

type	D ± 5%	L ± 5	C max.	d	mass approx. g
2322 661 91019	8	54	7	0,8	0,8
2322 661 93001	8	54	13	0,8	1,3
2322 662 91004	10	55	11	0,8	0,9
2322 662 91006	12	56	11	0,8	1,1
2322 662 93015	10	55	13	0,8	1,6
2322 662 93017	12	56	13	0,8	2,1
2322 663 91002	16	58	11	0,8	1,7
2322 663 93006	16	58	13	0,8	3,3
2322 664 91002	20	60	11	0,8	2,2
2322 664 93014	20	60	13	0,8	4,8

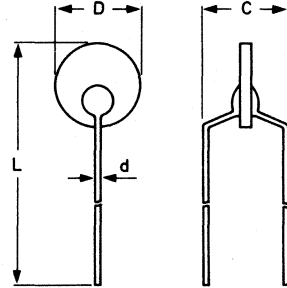
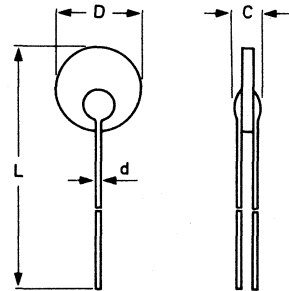

Fig. 1.

2322 660 91017	4,5	52,5	4	0,5	0,4
2322 660 93006	4,5	52,5	5,5	0,5	0,5
2322 660 93011	4,5	52,5	5,5	0,5	0,5
2322 660 93012	4,5	52,5	5,5	0,5	0,5
2322 660 93013	4,5	52,5	5,5	0,5	0,5
2322 660 93014	4,5	52,5	5,5	0,5	0,5
2322 661 91021	8	54	4	0,5	0,6
2322 661 93002	8	54	5,5	0,5	1,0
2322 662 91005	10	55	4	0,5	0,7
2322 662 91007	12	56	4	0,5	0,9
2322 662 93016	10	55	5,5	0,5	1,4
2322 662 93018	12	56	5,5	0,5	1,8
2322 663 91003	16	58	4	0,5	1,4
2322 663 93007	16	58	5,5	0,5	3,0
2322 664 91003	20	60	4	0,5	1,9
2322 664 93015	20	60	5,5	0,5	4,6
2322 672 91016	3	51,5	4	0,5	0,25
2322 672 93003	3	51,5	5,5	0,5	0,3



7271460.1

Fig. 2.

## ELECTRICAL DATA

Table 2 Low-voltage PTC thermistors:  $V_{\max}$  at + 55 °C = 60 V;  $T_s = + 115$  °C

R25 $\Omega$ $\pm 25\%$	R115 $\Omega$ max.	$I_{\text{stat peak}}$ A		$I_{\text{max}}$ A	$t_{\text{resp}}$ s	D mW/K	$I_{\text{res}}$ mA	$R_s$ $\Omega$ min.	catalogue number
		at 25 °C	at 55 °C	at 0 °C and 60 V	at 25 °C and $I_{\text{max}}$				
1,65	3,5	0,85	0,64	7,5	3	20	63	6,2	2322 664 91002
1,65	3,5	0,75	0,57	6,5	3	15	53	7,5	664 91003
2,3	5	0,63	0,47	5,25	3	15	51	9,1	663 91002
2,3	5	0,50	0,37	4,5	3	10	36	11	663 91003
3,7	7	0,44	0,33	3,5	3	12	39	13,5	662 91006
3,7	7	0,35	0,26	2,75	3	7,5	29	18	662 91007
5,6	12	0,34	0,25	2,7	3	11	31	16	662 91004
5,6	12	0,26	0,195	2	3	6,5	22	24	662 91005
9,4	20	0,25	0,19	1,9	3	10	28	22	661 91019
9,4	20	0,18	0,135	1,3	3	5	16	36	661 91021
25	55	0,09	0,068	0,65	3	4	12,5	68	660 91017
55	120	0,059	0,044	0,4	3	3,5	10,5	95	672 91016

Table 3 High-voltage PTC thermistors:  $V_{\max}$  at + 55 °C = 245 V;  $T_s = + 115$  °C

R25 $\Omega$ $\pm 25\%$	R115 $\Omega$ max.	$I_{\text{stat peak}}$ A		$I_{\text{max}}$ A	$t_{\text{resp}}$ s	D mW/K	$I_{\text{res}}$ mA	$R_s$ $\Omega$ min.	catalogue number
		at 25 °C	at 55 °C	at 0 °C and 245 V	at 25 °C and $I_{\text{max}}$				
3,7	8	0,55	0,41	4,9	6	20	18	47	2322 664 93014
3,7	8	0,5	0,38	4,5	6	15,5	17	51	664 93015
6	15	0,4	0,3	3,0	6	16	16	75	663 93006
6	15	0,35	0,25	3,5	6	11	13	91	663 93007
10	25	0,27	0,2	1,8	7	12,5	14	120	662 93017
10	25	0,235	0,175	1,5	7	9	10	150	662 93018
15	40	0,215	0,162	1,3	7	11	14	180	662 93015
15	40	0,162	0,120	1	7	6,5	8,5	220	662 93016
25	60	0,150	0,115	0,9	7	10	11,5	240	661 93001
25	60	0,115	0,087	0,7	7	5,5	7	330	661 93002
70	160	0,059	0,045	0,25	8	4	5,5	910	660 93006
120	400	0,045	0,034	0,19	8	7	5	1100	660 93011
150	400	0,036	0,027	0,1	8	4	4,5	2200	672 93003
600	3000	0,020	0,015	0,085	8	7	4,5	2200	660 93012
1200	4000	0,014	0,011	0,060	8	7	4,5	2700	660 93013
1500	5000	0,013	0,010	0,055	8	7	4,5	3000	660 93014

Definitions of terms used in Tables 2 and 3.

$V_{\max}$	max. d.c. or a.c. voltage at + 55 °C.
$I_{\text{stat peak}}$	max. stationary operating current.
$I_{\text{max}}$	max. current at $T_{\text{amb}} = 0$ °C.
$t_{\text{resp}}$	time taken for the thermistor to reach the switching temperature.
D	dissipation factor measured in still air.
$I_{\text{res}}$	residual current at $V_{\max}$ .





HUMIDITY SENSOR





## HUMIDITY SENSOR

## QUICK REFERENCE DATA

Humidity range	10 to 90% R.H.
Capacitance at +25 °C, 43% R.H. and 100 kHz	122 pF ± 15%
Sensitivity between 33 and 43% R.H.	0,4 ± 0,05 pF/% R.H.
Frequency range	1 kHz to 1 MHz
Maximum a.c. or d.c. voltage	15 V
Storage humidity range	0 to 100% R.H.
Ambient temperature range	
Operating	0 to +85 °C
Storage	-25 to +85 °C

## APPLICATION

For humidity measurements in e.g. electronic hygrometers for domestic use, laundry dryers with automatic switch-off, self-regulating air humidifiers.

## DESCRIPTION

This capacitive atmospheric humidity sensor consists of a non-conductive foil, which is covered on both sides with a layer of gold. The dielectric constant of the foil changes as a function of the relative humidity of the ambient atmosphere and, accordingly, the capacitance value of the sensor is a measure for relative humidity. The foil is clamped between contact springs and assembled in a plastic housing. It is provided with two connecting pins fitting printed-wiring boards with a grid pitch of 2,54 mm, provision is also made for fastening with 3 mm bolts. The characteristics are not affected by an incidental condensation of water on the sensor foil. It should not be exposed to acetone vapour.

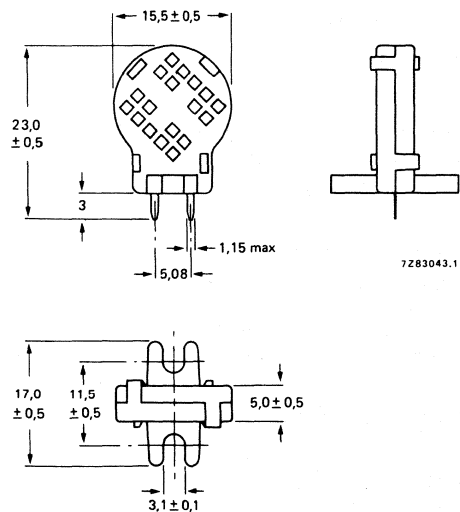

Fig. 1 Dimensions in mm.

**MECHANICAL DATA****Outlines**

See Fig. 1.

**Marking**

PHILIPS H1

**Mass**

1,3 g approximately

**Mounting**

The item can be soldered directly onto a printed-wiring board or can be fastened with 3 mm bolts.

**Soldering**

## Solderability

max. 240 °C, max. 4 s

## Resistance to heat

max. 240 °C, max. 4 s

**Robustness of terminations**

## Tensile strength

10 N

**Impact**

## Free fall

1 m

**Inflammability**

uninflammable

**ELECTRICAL DATA**

## Humidity range

10 to 90% R.H.

## Capacitance at +25 °C. 43% R.H., 100 kHz

122 pF ± 15%

Tan  $\delta$  at +25 °C and 100 kHz

&lt; 3,5%

## Sensitivity between 33 and 43% R.H.

0,4 ± 0,05 pF/% R.H.

## Frequency range

1 kHz to 1 MHz

## Temperature dependence

0,1% R.H./K

Response time (to 90% of indicated R.H.  
change at +25 °C, in circulating air)  
between 10 and 43% R.H.  
between 43 and 90% R.H.

&lt; 3 min.

&lt; 5 min.

## Hysteresis (for R.H. excursion of 10 to 90 to 10%)

3% approximately

## Maximum a.c. or d.c. voltage

15 V

## Storage humidity range

0 to 100% R.H.

## Ambient temperature range

## Operating

0 to +85 °C

## Storage

-25 to +85 °C



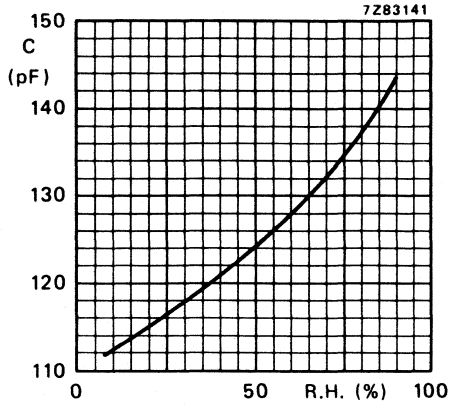

Fig. 2 Typical capacitance/relative humidity characteristic.

#### QUALITY LEVEL

Sampling and data evaluation for quality level according to MIL-STD-105D.

- A.Q.L. 0,25% – Inoperatives
- A.Q.L. 1% – Electrical
- A.Q.L. 1,5% – Mechanical

#### PACKAGING

500 pieces per box.





## INDEX OF CATALOGUE NUMBERS

catalogue number	type	page	catalogue number	type	page
2322 552	VDR	19	2322 660 91001	PTC	219
553		23	91006/9		222
554		27	91017		396
555		31	93001		229
564		35	93006		397
581		39	93011/14		397
592		113	661 91002/5		233
593		49	91019		396
594		55	91021		396
595		61	93001/2		397
2322 600 93	LDR	70	662 91001		238
600 94		72	91004/7		396
600 95		74	91016		241
2322 610	NTC	103	93006		244
611		108	93015/18		397
626 1		109	93036		247
626 2		115	93066		251
628 9		120	98001		255
633 0/1		123	98003		255
633 2		127	98009		263
635		133	98013		271
636		137	663 91002/3		396
637		141	91006		275
640 1		145	9400.		279
640 19		149	9500.		285
640 90004		151	93006/7		397
640 90005		157	664 91002/3		396
640 90007		163	91086		291
640 90012		168	93014/15		397
640 90013		170	670 90003		295
640 90014		174	672 91002/11		297
640 90015		177	91016		396
640 90021		163	91026/35		297
640 98004		151	92045/53		305
640 98005		157	93003		397
640 98013		170	98001		313
640 98015		177	678 93001/2		319
642 6		181	680 00001		323
642 7		188	03001		325
644 1		191	04001		327
644 90004		193	04002		329
644 90005		193	04003		331
644 90012		199	04004		333
66. 1... 1		353	04022		335
66. 1... 3		371	90019		337
			90047		341
			90136		345
			93009/11		349
			2322 691 90001	H.S.	401







## NON-LINEAR RESISTORS



VOLTAGE DEPENDENT RESISTORS (VDR)

LIGHT DEPENDENT RESISTORS (LDR)

NEGATIVE TEMPERATURE COEFFICIENT THERMISTORS (NTC)

POSITIVE TEMPERATURE COEFFICIENT THERMISTORS (PTC)

HUMIDITY SENSOR.



**Argentina:** PHILIPS ARGENTINA S.A., Div. Elcoma, Vedia 3892, 1430 BUENOS AIRES, Tel. 541-7141/7242/7343/7444/7545.  
**Australia:** PHILIPS INDUSTRIES HOLDINGS LTD., Elcoma Division, 67 Mars Road, LANE COVE, 2066, N.S.W., Tel. 427 0888.  
**Austria:** ÖSTERREICHISCHE PHILIPS BAUELEMENTE Industrie G.m.b.H., Triester Str. 64, A-1101 WIEN, Tel. 62 91 11.  
**Belgium:** N.V. PHILIPS & MBLÉ ASSOCIATED, 9 rue du Pavillon, B-1030 BRUXELLES, Tel. (02) 242 74 00.  
**Brazil:** IBRAPE, Caixa Postal 7383, Av. Brigadeiro Faria Lima, 1735 SAO PAULO, SP, Tel. (011) 211-2600.  
**Canada:** PHILIPS ELECTRONICS LTD., Electro Devices Div., 601 Milner Ave., SCARBOROUGH, Ontario, M1B 1M8, Tel. 292-5161.  
**Chile:** PHILIPS CHILENA S.A., Av. Santa Maria 0760, SANTIAGO, Tel. 39-4001.  
**Colombia:** SADAPE S.A., P.O. Box 9805, Calle 13, No.51 + 39, BOGOTA D.E. 1., Tel. 600600.  
**Denmark:** MINIWATT A/S, Strandlodsvej 2, P.O. Box 1919, DK 2300 COPENHAGEN S, Tel. (01) 54 11 33.  
**Finland:** OY PHILIPS AB, Elcoma Division, Kaivokatu 8, SF-00100 HELSINKI 10, Tel. 17271.  
**France:** R.T.C. LA RADIODÉCHIQUE-COMPELEC, 130 Avenue Ledru Rollin, F-75540 PARIS 11, Tel. 355-44-99.  
**Germany:** VALVO, UB Baelemente der Philips G.m.b.H., Valvo Haus, Burchardstrasse 19, D-2 HAMBURG 1, Tel. (040) 3296-0.  
**Greece:** PHILIPS S.A. HELLENIQUE, Elcoma Division, 52, Av. Syngrou, ATHENS, Tel. 9215111.  
**Hong Kong:** PHILIPS HONG KONG LTD., Elcoma Div., 15/F Philips Ind. Bldg., 24-28 Kung Yip St., KWAI CHUNG, Tel. (0)-245121.  
**India:** PEICO ELECTRONICS & ELECTRICALS LTD., Elcoma Div., Ramon House, 169 Backbay Reclamation, BOMBAY 400020, Tel. 221012.  
**Indonesia:** P.T. PHILIPS-RALIN ELECTRONICS, Elcoma Div., Panin Bank Building, 2nd Fl., Jl. Jend. Sudirman, P.O. Box 223, JAKARTA, Tel. 716131.  
**Ireland:** PHILIPS ELECTRICAL (IRELAND) LTD., Newstead, Clonskeagh, DUBLIN 14, Tel. 693355.  
**Italy:** PHILIPS S.p.A., Sezione Elcoma, Piazza IV Novembre 3, I-20124 MILANO, Tel. 2-6752.1.  
**Japan:** NIHON PHILIPS CORP., Shuwa Shinagawa Bldg., 26-33 Takanawa 3-chome, Minato-ku, TOKYO (108), Tel. 448-5611.  
 (IC Products) SIGNETICS JAPAN LTD., 8-7 Sanbancho Chiyoda-ku, TOKYO 102, Tel. (03) 230-1521.  
**Korea:** PHILIPS ELECTRONICS (KOREA) LTD., Elcoma Div., Philips House, 260-199 Itaewon-dong, Yongsan-ku, C.P.O. Box 3680, SEOUL, Tel. 794-4202.  
**Malaysia:** PHILIPS MALAYSIA SDN. BERHAD, No. 4 Persiaran Barat, Petaling Jaya, P.O.B. 2163, KUALA LUMPUR, Selangor, Tel. 77 44 11.  
**Mexico:** ELECTRONICA, S.A. de C.V., Carr. Mexico-Toluca km. 62.5, TOLUCA, Edo. de Mexico 50140, Tel. Toluca 91 (721) 613-00.  
**Netherlands:** PHILIPS NEDERLAND, Marktgroep Elonco, Postbus 90050, 5600 PB EINDHOVEN, Tel. (040) 793333.  
**New Zealand:** PHILIPS ELECTRICAL IND. LTD., Elcoma Division, 110 Mt. Eden Road, C.P.O. Box 1041, AUCKLAND, Tel. 605-914.  
**Norway:** NORSK A/S PHILIPS, Electronica Dept., Sandstuveien 70, OSLO 6, Tel. 680200.  
**Peru:** CADESA, Av. Alfonso Ugarte 1268, LIMA 5, Tel. 326070.  
**Philippines:** PHILIPS INDUSTRIAL DEV. INC., 2246 Pasong Tamo, P.O. Box 911, Makati Comm. Centre, MAKATI-RIZAL 3116, Tel. 86-89-51 to 59.  
**Portugal:** PHILIPS PORTUGUESA S.A.R.L., Av. Eng. Duarte Pacheco 6, 1009 LISBOA Codex, Tel. 683121.  
**Singapore:** PHILIPS PROJECT DEV. (Singapore) PTE LTD., Elcoma Div., Lorong 1, Toa Payoh, SINGAPORE 1231, Tel. 2538811.  
**South Africa:** EDAC (Pty.) Ltd., 3rd Floor Rainer House, Upper Railway Rd. & Ove St., New Doornfontein, JOHANNESBURG 2001, Tel. 614-2362/9.  
**Spain:** MINIWATT S.A., Balmes 22, BARCELONA 7, Tel. 301 63 12.  
**Sweden:** PHILIPS KOMPONENTER A.B., Lidingövägen 50, S-11584 STOCKHOLM 27, Tel. 08/7821000.  
**Switzerland:** PHILIPS A.G., Elcoma Dept., Allmendstrasse 140-142, CH-8027 ZÜRICH, Tel. 01-4882211.  
**Taiwan:** PHILIPS TAIWAN LTD., 3rd Fl., San Min Building, 57-1, Chung Shan N. Rd, Section 2, P.O. Box 22978, TAIPEI, Tel. (02)-5631717.  
**Thailand:** PHILIPS ELECTRICAL CO. OF THAILAND LTD., 283 Silom Road, P.O. Box 961, BANGKOK, Tel. 233-6330-9.  
**Turkey:** TÜRK PHILIPS TICARET A.Ş., EMET Department, Inonu Cad. No. 78-80, İSTANBUL, Tel. 43 59 10.  
**United Kingdom:** MULLARD LTD., Mullard House, Torrington Place, LONDON WC1E 7HD, Tel. 01-580 6633.  
**United States:** (Active Devices & Materials) AMPEREX SALES CORP., Providence Pike, SLATERSVILLE, R.I. 02876, Tel. (401) 762-9000.  
 (Passive Devices) MESPO-ELECTRA INC., Columbia Rd., MORRISTOWN, N.J. 07960, Tel. (201) 539-2000  
 (Passive Devices & Electromechanical Devices) CENTRAL LAB INC., 5855 N. Glen Park Rd., MILWAUKEE, WI 53201, Tel. (414) 228-7380.  
 (IC Products) SIGNETICS CORPORATION, 811 East Arques Avenue, SUNNYVALE, California 94086, Tel. (408) 739-7700.  
**Uruguay:** LUZILECTRON S.A., Avda Uruguay 1287, P.O. Box 907, MONTEVIDEO, Tel. 91 43 21.  
**Venezuela:** IND. VENEZOLANAS PHILIPS S.A., Elcoma Dept., A. Ppal de los Ruices, Edif. Centro Colgate, CARACAS, Tel. 3605 11

**For all other countries apply to:** Philips Electronic Components and Materials Division, International Business Relations, Building BAE-3, P.O. Box 218, 5600 MD EINDHOVEN, The Netherlands, Tel. +31 40 72 33 04, Telex 35000 phct n/nl be vec.